

Rigid and Intermediate Metal Conduit Fittings

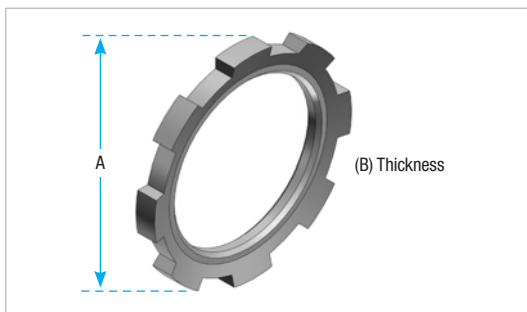

**Steel or malleable iron (steel thru 2 in.)
or Aluminum 624**

Many of the T&B standard conduit and cable fittings are furnished with "case hardened locknuts". This exclusive feature means the locknut tightens up against the box without deforming; the locknut bites into the box providing a positive ground; the fitting can be tightened from outside the box

Locknuts

Stl. or M.I.	Cat. No.		Size (in.)	Dimensions (in.)	
	Alum.	SST		A	B
139*†	—	—	1/4	27/32	5/32
140*	—	—	3/8	15/16	5/32
141**	141AL	141SST	1/2	1-7/64	5/32
142-TB**	142AL	142SST	3/4	1-3/8	3/16
143	143AL	143SST	1	1-11/16	13/64
144	144AL	144SST	1-1/4	2-5/32	13/64
145	145AL	145SST	1-1/2	2-1/2	13/64
146-TB	146AL	146SST	2	3	7/32
147	147AL	—	2-1/2	3-9/16	13/32
148	148AL	—	3	4-3/16	13/32
149	149AL	—	3-1/2	4-13/16	15/32
150	150AL	—	4	5-5/16	15/32
151	151AL	—	4-1/2	5-15/16	17/32
152	152AL	—	5	6-1/2	17/32
153	153AL	—	6	7-3/4	17/32

* Hex shape

** Case hardened locknuts

Aluminum locknuts comply with federal standard of copper-free aluminum; less than 0.4% copper
For Dura-Plate® finish, add prefix 040- to Cat. No. Consult your Regional Sales Office for details

† Not UL or CSA certified

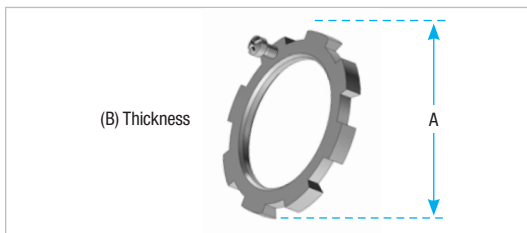

Steel or malleable iron (steel thru 2 in.)

Use anywhere an ordinary locknut is installed to ensure positive bonding of conduit to box and prevent loosening due to vibration. Also can be used for Service Entrance applications in conformance with Code. T&B rigid conduit and EMT (thinwall) fittings comply with Federal Specification WF 408c.

Bonding Locknuts



Cat. No.	Size (in.)	Screw Size (in.)	Dimensions (in.)	
			A	B
106	1/2	8-32 x 7/16	1-3/8	0.125
107	3/4		1-5/8	0.140
108	1		1-15/16	0.170
109	1-1/4		2-5/32	0.170
110-TB	1-1/2		2-1/2	0.170
111	2		3	0.187
112-TB	2-1/2	1/4-20 x 5/8	3-13/32	0.375
113-TB	3		4-13/16	0.375
114	3-1/2		4-29/32	0.438
115-TB	4		5-7/16	0.438

For Dura-Plate® finish, add prefix 040- to Cat. No. Consult your Regional Sales Office for details
Steel finish: zinc plated

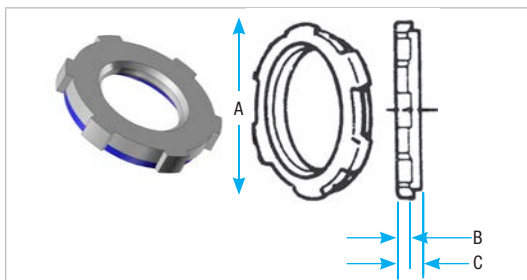

Molded Santprene Seal / Colour: Blue

Provides positive seal against water and oil. For use with rigid and intermediate metal conduits, or fittings to provide watertight or raintight seal at all enclosures. NPS threads..

Fittings



Cat. No.	Size (in.)	Dimensions (in.)		
		A	B	C
141SL	1/2	1.140	1/8	1/4
142SL	3/4	1.420	5/32	9/32
143SL	1	1.770	11/64	9/32
144SL	1-1/4	2.281	11/64	5/16
145SL	1-1/2	2.598	11/64	9/32
146SL	2	3.175	3/16	19/64

Steel finish: zinc plated

Rigid and Intermediate Metal Conduit Fittings

Sealing Rings with Stainless Steel Retainer



Sealing Ring-Santoprene Thermoplastic Rubber

These sealing rings provide a liquid tight, dust tight, seal of fitting at enclosures

Cat. No.	Conduit Size (in.)	Dimensions (in.)	
		A	B±1/64
5302	1/2	1-11/64	3/4
5303	3/4	1-1/2	15/16
5304	1	1-3/4	1-11/64
5305	1-1/4	2-9/64	1-1/2
5306	1-1/2	2-27/64	1-3/4
5307	2	2-59/64	2-15/64
531008	2-1/2	3-7/16	2-43/64
5309	3	4-5/64	3-19/64
5311	4	5-9/32	4-19/64

NEMA 3R, 4, 6 and 13

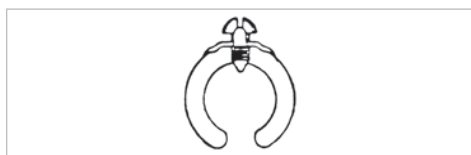

Series 3650

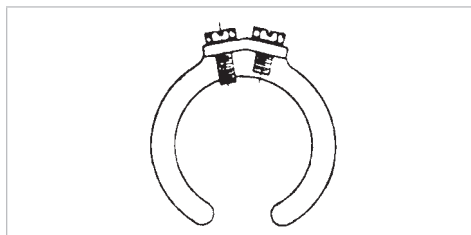

Series 3651

Bonding and Grounding Wedges

Application

To effectively bond terminating fitting or conduit to a box or enclosure

Features

- Sizes 3/4 in. thru 6 in. equipped with an additional bonding screw to install bonding jumper where required
- Can be added to an existing installation without disconnecting conductors

Standard Material/Finish

1/2 in. size
Steel/Electro-zinc Plated
3/4 in. thru 6 in. size
Bronze/TiPlated

Range

1/2 in. thru 6 in. conduit

Conformity

UL 467
C.S.A. C22.2 No. 41
NFPA70-2008 (ANSI)
Federal Specification A-A-50552



Especially suited for grounding old work, but equally convenient for new, grounding wedges provide grounding without a jumper except in concentric knockouts. When a jumper is required, it fits under a set screw in the grounding wedge.

Update existing installations to meet code requirements for bonding (CEC Section 10-806) without disconnecting wiring. Use on new wiring also.

1. Loosen bushing and position wedge
2. Tighten bushing and bonding screw

Bonding and Grounding Wedges



Cat. No.	Size (in.)
3650	1/2
3651	3/4
3652	1
3653	1-1/4
3654	1-1/2
3655	2
3656	2-1/2
3657	3
3658	3-1/2
3659	4
3661	5
3662	6

Rigid and Intermediate Metal Conduit Fittings

Blackjack® — Conduit Grounding Bushings

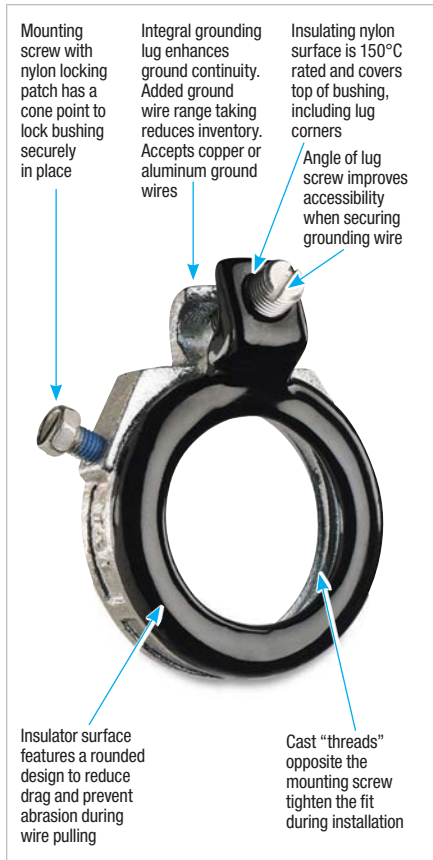

Innovative design makes installation quicker, easier.

The Blackjack® Grounding Bushing never has to be threaded onto a conduit. It is simply placed in position on either a threaded or non-threaded rigid or IMC conduit, with the grounding lug in perfect position to accept the grounding wire. Even in tight installations, it's as simple as one, two, three. Compare the installation with conventional bushings that must be threaded onto the conduit. In tight areas, you may have to remove the grounding lug, keep up with the loose parts, and then reattach the lug. Then you still have to twist and turn the bushing to get the lug in position to accept the grounding wire. The Blackjack® bushing does away with these needless delays for good, making it the ideal grounding bushing and the only logical choice for small spaces, corners, and multiple conduit runs. And, because the grounding lug is an integral part of the bushing, it is designed not to fall off or get lost.

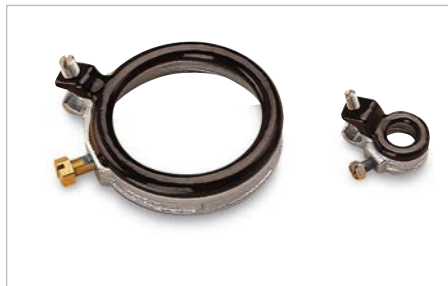

Innovative design improves performance

The Blackjack® bushing provides superior ground continuity

The design of the Blackjack® bushing has an integral, cast-on grounding lug for better ground continuity. This means that the Blackjack® bushing stands up to intense loads.

Secure grip forms lasting bond

The Blackjack® bushing's cone point mounting screw bites securely into both **threaded and non-threaded** rigid conduits. And the Blackjack® bushing's nylon locking patch is designed to prevent the screw from loosening due to vibration.

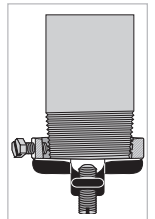

Reduce inventory

Because the Blackjack® Grounding Bushing is designed for threaded and non-threaded conduits, and the ground lugs are designed to handle an extended range, the number of parts in inventory is reduced by up to two-thirds without losing any application coverage.

Blackjack® — Conduit Grounding Bushings



Lug Screw:

- 14-4: Slotted
- 14-2/0: Slotted
- 6-4/0: Internal Hex Drive

Standard Material/Finish

Body: Malleable Iron or Aluminum

Mounting Screw: (1/2 in.-2 in.)
Stainless Steel,
(2-1/2 in.-6 in.) Brass

Lug Screw: Stainless Steel

Finish: Zinc Plated or Mechanical Galvanized

Range

Conduit: 1/2 in. thru 6 in. threaded or threadless rigid/IMC

Wire Range: #14 AWG to 4/0 AWG CU/AL

Conformity

UL 514B & UL 467

CSA C22.2 No. 18.3 & CSA C22.2 No. 41

Rigid and Intermediate Metal Conduit Fittings

Blackjack® – Conduit Grounding Bushings



Cat. No.		Conduit Size (in.)	Dim.				E Max.	Wire Range
Zinc Plated Malleable Iron	Aluminum		ØA Max.	ØB Max.	ØC Max.	ØD Max.		
BG050-14-20	BGA050-14-20	1/2	1.251	0.569	1.181	2.134	0.696	14-2/0
BG050-14-4	BGA050-14-4		1.251	0.569	1.027	1.940		14-4
BG075-14-20	BGA075-14-20	3/4	1.533	0.772	1.221	2.414		14-2/0
BG075-14-4	BGA075-14-4		1.533	0.772	1.030	2.168		14-4
BG100-14-20	BGA100-14-20	1	1.783	0.993	1.181	2.581		14-2/0
BG100-14-4	BGA100-14-4		1.783	0.993	1.027	2.368		14-4
BG125-14-20	BGA125-14-20	1-1/4	2.220	1.319	1.181	2.987	0.759	14-2/0
BG150-14-20	BGA150-14-20	1-1/2	2.470	1.553	1.181	3.236	0.696	14-2/0
BG200-14-20	BGA200-14-20	2	2.830	2.010	1.181	3.766		14-2/0
BG250-14-20	BGA250-14-20	2-1/2	3.148	2.412	1.181	4.341	0.978	14-2/0
BG250-6-40	BGA250-6-40		3.148	2.412	1.524	4.526		6-4/0
BG300-14-20	BGA300-14-20	3	4.042	3.022	1.181	4.966		14-2/0
BG300-6-40	BGA300-6-40		4.042	3.022	1.524	5.139		6-4/0
BG350-14-20	BGA350-14-20	3-1/2	4.542	3.491	1.181	5.467		14-2/0
BG350-6-40	BGA350-6-40		4.542	3.491	1.524	5.639		6-4/0
BG400-14-20	BGA400-14-20	4	5.042	3.975	1.181	5.966	0.978	14-2/0
BG400-6-40	BGA400-6-40		5.042	3.975	1.524	6.139		6-4/0
BG500-14-20	BGA500-14-20	5	6.136	4.991	1.181	7.045		14-2/0
BG500-6-40	BGA500-6-40		6.136	4.991	1.524	7.207		6-4/0
BG600-14-20	BGA600-14-20	6	7.199	6.009	1.181	8.087		14-2/0
BG600-6-40	BGA600-6-40		7.199	6.009	1.524	8.409		6-4/0

Suggested Specifications
Insulated grounding and bonding bushing
(Series BG050-BG600)

Where code requires bonding and grounding of single or multiple metal conduits, or positive bonding and grounding of metal conduit to the box, enclosure or auxiliary gutter, the end of the conduit shall be equipped with an insulated metallic grounding and bonding bushing Series BG050-14-20 as manufactured by Thomas & Betts.

Grounding and bonding bushings used shall be approved for the purpose and

(i) Shall be of malleable iron/steel/aluminum construction adequately protected against corrosion.

(ii) Bushing insulator shall be listed or certified for 150°C/302°F application with a flammability rating of 94V-0. Insulator must be positively locked in place.

* Mechanical galvanization is available in the 3870 Series; add suffix **MG** to Cat. No.

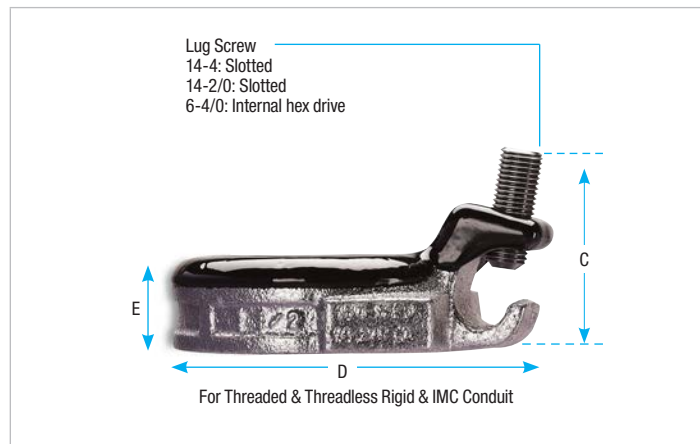
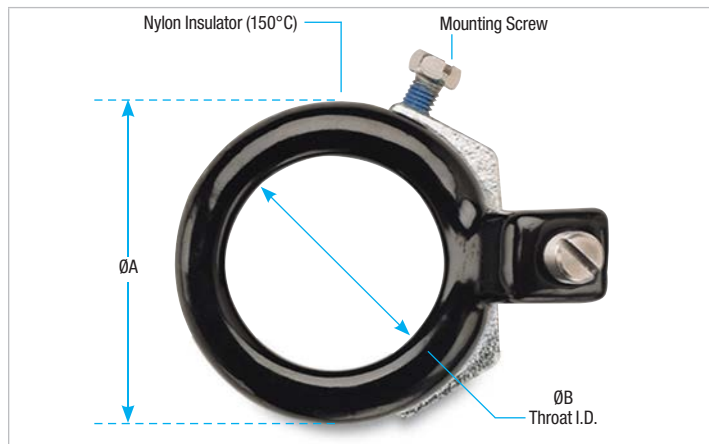

Rigid and Intermediate Metal Conduit Fittings

Threaded Insulated Grounding Bushing

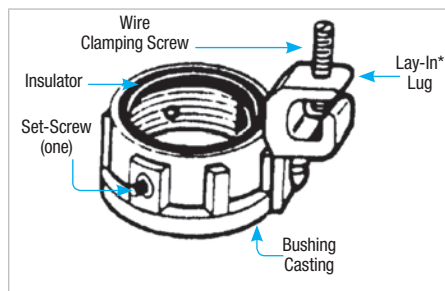

Application

- For quick installation of bonding jumper to multiple metal conduits (Rigid and IMC)
- Designed to bush conductors and prevent insulation damage

Features

- Ease of installation, lay in lug design
- Cast malleable iron body designed to lock insulator in place within body, reducing common assembly problem resulting in dislodging of insulator
- Insulator rated for 150°C/302°F application

Standard Material / Finish

Body: Electro-zinc plated

Lay-in lug: Aluminum/tin-plated

Insulator: Thermoplastic
150°C/302°F

Application with 94V-0 flammability



Cat. No.	Conduit Size (in.)	Bushing Dia. (in.)	Throat Dia. (in.)	Lug Length (in.)	Swing Radius (in.)	Bushing Height (in.)	Wire Range AWG CU/AL
3870-TB	1/2	1.125	0.560	1.310	1.212	0.657	14-4
3861		1.125	0.560	1.675	1.402		8-2/0
3871-TB	3/4	1.420	0.742	1.310	1.360	0.660	14-4
3862		1.420	0.742	1.675	1.550		8-2/0
3872	1	1.770	0.944	1.310	1.535	0.735	14-4
3882		1.770	0.944	1.675	1.725		8-2/0
3873	1-1/4	2.190	1.242	1.310	1.745	0.770	14-4
3883		2.190	1.242	1.675	1.935		8-2/0
3874	1-1/2	2.468	1.449	1.310	1.884	0.940	14-4
3884		2.468	1.449	1.675	2.074		8-2/0
3875	2	3.031	1.860	1.310	2.165	0.975	14-4
3889		3.031	1.860	1.675	2.355		8-2/0
3876	2-1/2	3.516	2.222	1.310	2.408	0.980	14-4
3886		3.516	2.222	1.675	2.598		8-2/0
3993	3	3.516	2.222	2.230	2.928	0.985	6-4/0
3877		4.234	2.761	1.310	2.767		14-4
3887	3	4.234	2.761	1.675	2.957	0.985	8-2/0
3994		4.234	2.761	2.230	3.287		6-4/0
3878	3-1/2	4.781	3.193	1.310	3.040	0.985	14-4
3863		4.781	3.193	1.675	3.230		8-2/0
3995	4	4.781	3.193	2.230	3.560	0.985	6-4/0
3879		5.328	3.623	1.310	3.314		14-4
3864	4	5.328	3.623	1.675	3.504	0.985	8-2/0
3996		5.328	3.623	2.230	3.834		6-4/0
3880	5	6.328	4.542	1.310	3.814	1.200	14-4
3865		6.328	4.542	1.675	4.000		8-2/0
3998	5	6.328	4.542	2.230	4.334	1.200	6-4/0
3881		7.406	5.458	1.310	4.353		14-4
3866	6	7.406	5.458	1.675	4.543	1.200	8-2/0
3999		7.406	5.458	2.230	4.875		6-4/0

Temperature rating 150°C

Meets Coast Guard Regulation CG293

For Dura-Plate® finish, add prefix 040- to Cat. No. Consult your Regional Sales Office for details

*Contact your Regional Sales Office for copper lay in lug

Rigid and Intermediate Metal Conduit Fittings

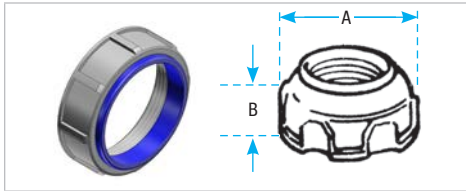

Nylon insulated metallic bushings
Steel or malleable iron (Steel thru 1-1/2 in.)

The Canadian Electric Code 10-906 (2) calls for protection of ungrounded conductors by means of smoothly rounded insulating surfaces at the entrance to raceways, pull boxes, junction boxes, etc. T&B insulated throat fittings, recognizable by the distinctive trademarked blue insulating liner in the throat, meet and surpass this Code requirement. In addition, T&B insulated fittings also reduce wire pulling effort by as much as 50%. Temperature rating 105°C.

Insulated Throat Fittings



Cat. No.	Steel or M.I.	Aluminum	Size (in.)	Dimensions (in.)	
				A	B
1222		1222AL	1/2	1-1/32	29/64
1223		1223AL	3/4	1-9/32	31/64
1224		1224AL	1	1-19/32	19/32
1225		1225AL	1-1/4	1-15/16	21/32
1226		1226AL	1-1/2	2-3/16	23/32
1227		1227AL	2	2-11/16	7/8
1228		1228AL	2-1/2	3-3/16	31/32
1229		1229AL	3	3-27/32	15/16
1230		1230AL	3-1/2	4-7/16	1-1/16
1231		1231AL	4	4-7/8	1-3/32
1232†		1232AL†	4-1/2	5-7/16	1-15/64
586		586AL	5	5-31/32	1-9/32
587		587AL	6	7-3/16	1-11/32

† Not CSA Certified
The aluminum series are not CSA certified

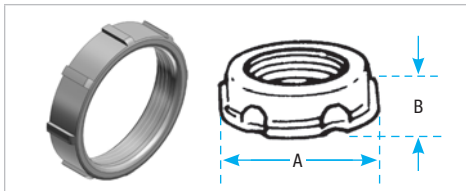

Aluminum, steel or malleable iron
(steel thru 1-1/2 in.)

Smoothly rounded shoulder covers end of conduit; broad flange covers knockout hole. High ribs make tightening easy with fingers or with wrench. 1/2 in.-1-1/2 in. sizes, formed in steel, have extra smooth shoulders. Locknut-type base gives improved bonding and resists loosening under conditions of vibration.

Metallic Bushings



Cat. No.	Steel or M.I.	Aluminum	Size (in.)	Dimensions (in.)	
				A	B
122		122AL	1/2	1-1/32	13/32
123		123AL*	3/4	1-9/32	13/32
124		124AL	1	1-19/32	1/2
125-TB		125AL	1-1/4	1-15/16	9/16
126		126AL	1-1/2	2-3/16	9/16
127		127AL	2	2-11/16	19/32
128		128AL	2-1/2	3-3/16	13/16
129		129AL	3	3-27/32	13/16
130-TB		130AL	3-1/2	4-7/16	15/16
131-TB		131AL	4	4-7/8	1
132-TB		—	4-1/2	5-7/16	1-5/64
133-TB		133AL	5	6-1/16	1-1/16
134-TB		134AL	6	7-3/16	1-1/16

* Not UL Listed or CSA Certified
For Dura-Plate® finish, add prefix 040- to Cat. No. Consult your Regional Sales Office for details

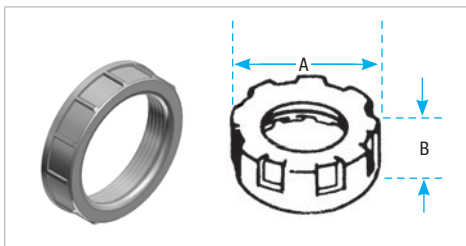

All Plastic Insulating Bushings

Impact-resistant plastic insulation. These bushings have ribs for gripping when installing. Perfect threads for easy thread on. UL Listed 105°C. NPT threaded.

Plastic Insulating Bushings



Cat. No.	Size (in.)	Dimensions (in.)	
		A	B
222-TB	1/2	1-1/16	3/8
223-TB	3/4	1-9/32	13/32
224	1	1-37/64	9/16
225-TB	1-1/4	2-1/32	9/16
226	1-1/2	2-15/64	9/16
227	2	2-25/32	5/8
228-TB	2-1/2	3-13/32	3/4
229-TB	3	4-3/32	3/4
230-TB	3-1/2	4-5/8	7/8
231	4	5-3/16	7/8
232	4-1/2	5-5/8	7/8
233	5	6-3/8	1
234	6	7-7/16	1

Flame retardant. UL Rated 94V-1

Rigid and Intermediate Metal Conduit Fittings

Insulating Bushing for Threadless Rigid Conduit and Intermediate Metal Conduit

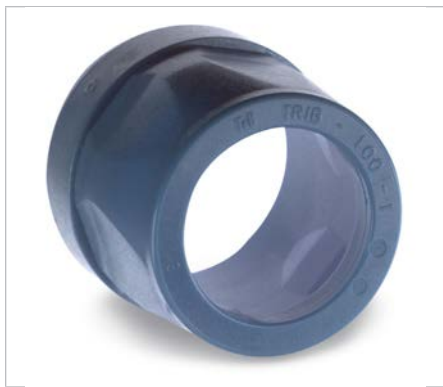

TRIB50 Series



1. Cut conduit end squarely. Remove sharp edges and burrs on inside and outside diameters by reaming or filing.
2. Slip the pop-on bushing over the end of the conduit.

Application

- When assembled to the end of a threadless conduit, provides a well rounded insulating surface over which conductors may be pulled or on which conductors may bear while in service

Features

- Designed to be popped onto, and bush, conduit end
- Fast easy installation without screws
- High impact thermoplastic construction

Standard Material

High impact thermoplastic listed for 105°C (221°F) application
Flammability Classification 94V-1

Standard Finish

As molded

Range

1/2 in. through 4 in. conduit

Conformity

UL 514B
ANSI C80.4
NFPA 70-2008 (ANSI)

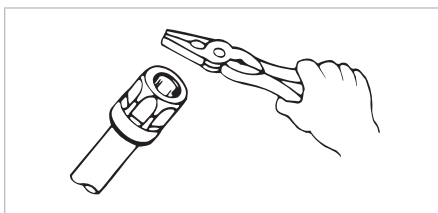

3. Using the flat surface of any standard utility tool such as an electricians pliers (or a hammer with a block of wood, for the larger sizes), strike the bushing on its top surface using a Series of light blows until the end of the conduit rests against the bushing throat and conduit stop.

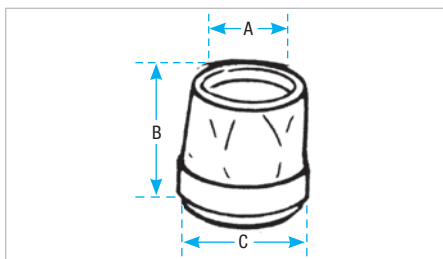
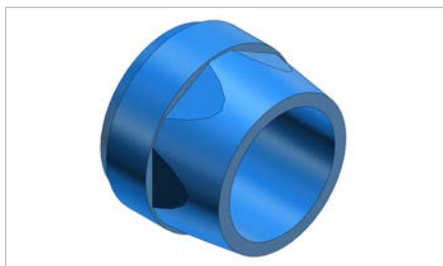

Insulated Metallic Bushing



Cat. No.	Size (in.)	Dimensions (in.)		
		A	B	C
TRIB-50	1/2	19/32	1-9/32	1-1/16
TRIB-75	3/4	25/32	1-25/64	1-1/4
TRIB-100	1	1	1-1/2	1-9/16
TRIB-125	1-1/4	1-5/16	1-5/8	1-59/64
TRIB-150	1-1/2	1-17/32	1-21/32	2-11/64
TRIB-200	2	1-31/32	1-13/16	2-11/16
TRIB-250	2-1/2	2-23/64	2	3-1/4
TRIB-300	3	2-59/64	2-7/32	3-29/32
TRIB-350	3-1/2	3-3/8	2-5/16	4-29/64
TRIB-400	4	3-27/32	2-13/32	5

I.M.C. sizes 1/2 in. thru 4 in.
UL Rated flame retardant 94V-1

Rigid and Intermediate Metal Conduit Fittings



3210 Series

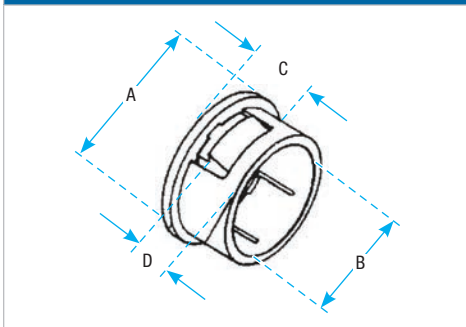

One-piece knockout bushing quickly snaps into outlet box, switch box, or other enclosure left vacant by wiring modifications or maintenance changes. Provides smooth, rounded insulation surface for easy wire pulling. Easily installed by hand, they are available to fit 1/2 in. through 2 in. knockouts. UL Listed 105°C. High impact thermoplastic.

Application

- To bush knockout openings in metal boxes or enclosures

Features

- One piece construction designed to snap in place
- High impact strength self-extinguishing, non-dripping (per UL 94) thermoplastic construction

Standard Material

Thermoplastic rated for 105°C (221°F) application

Standard Finish

As molded

Range

- 0.875 in. through 2.469 in. nominal diameter knockout opening (1/2 in. through 2 in. trade size knockouts)
- HWall thickness of box or enclosure 0.095 in. max. up to 1 in. trade size. 0.140 in. max. 1-1/4 in. through 2 in. trade size

Conformity

UL 514B
CSA C22.2 No. 18.3
NFPA 70-2008 (ANSI)



Knockout Bushings

Cat. No.	Trade Size (in.)	For use in KO* $\pm .032/-0.16$ (in.)	A (in.)	B (in.)	Wall Thickness of Elec. Box (in.)	C (in.)	D (in.)
3210	1/2	0.875	1.000	0.725	0.095 MAX	0.360	0.180
3211	3/4	1.109	1.215	0.940			
3212	1	1.375	1.500	1.200			
3213	1-1/4	1.734	1.865	1.550	0.140 MAX	0.400	0.210
3214	1-1/2	1.984	2.240	1.760			
3215	2	2.469	2.740	2.245			

* Per UL and NEMA standards
Material: Thermoplastic
Flammability classification of 94V-1 Per UL 94
Service temperature: -40°C to 105°C

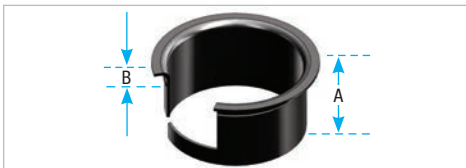

Slip over wires — insert into bushing — snaps into place High dielectric nylon, 105°C.

An Insuliner® sleeve snapped into a regular bushing makes a CSA Listed insulated bushing. For standard rigid conduit, EMT (thinwall conduit) or any standard bushed outlet. Especially suitable for use with flexible metallic conduit.

Converts ordinary bushing to code approved insulated bushing without disturbing wiring.

INSULINER® Sleeves



Cat. No.	Size (in.)	Dimensions (in.)	
		A	B
422	1/2	5/8	0.022
423	3/4	11/16	0.025
424	1	7/8	0.040
425	1-1/4	1	
426-TB	1-1/2	1	0.050
427-TB	2	1-1/8	
428-TB	2-1/2	1-1/4	0.035
429	3	1-1/2	
430-TB	3-1/2	1-25/32	
431	4	2-1/32	
433	5	2-1/2	
434	6	2-1/2	

Oxygen index >28°

Rigid and Intermediate Metal Conduit Fittings

Knockout Plugs

Application

- To bush knockout openings in metal boxes or enclosures

Features

- One piece construction designed to snap in place
- High impact strength self extinguishing non-dripping (per UL 94) thermoplastic construction

Standard Material

Thermoplastic rated for 105°C (221°F) application

Standard Finish

As molded

Range

- 0.875 in. through 2.469 in. nominal diameter knockout opening (1/2 in. through 2 in. trade size knockouts)
- Wall thickness of box or enclosure
0.095 in. max. up to 1 in. trade size
0.140 in. max. 1-1/4 in. through 2 in. trade size

Conformity

UL 514B
CSA C22.2 No. 18.3
NFPA 70-2008 (ANSI)

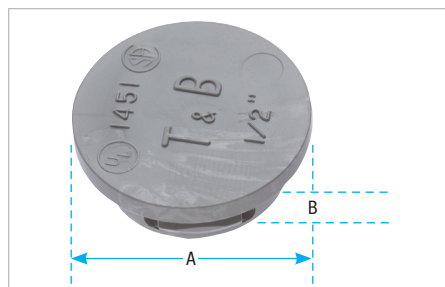

105°C rated by UL Made from flame retardant, non-dripping thermoplastic.

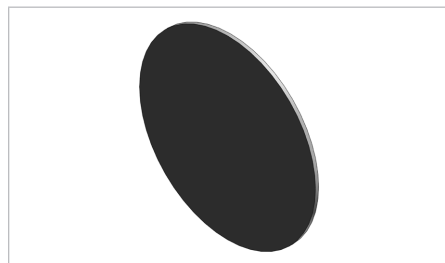

A penny under a bushing will seal the end of the conduit during construction. Made to fit any bushing. Completely salvageable.



Cat. No.	Knockout Trade Size (in.)	Dimensions (in.)	
		A	B
1451	1/2	1.060	0.400
1452	3/4	1.300	
1453	1	1.590	
1454	1-1/4	1.860	0.450
1455	1-1/2	2.240	0.570
1456	2	2.740	

Wall thickness of electrical box 0.095 max.
Meets Coast Guard Regulation CB293

Pennies — Steel



Cat. No.	Size (in.)
815-TB	1/2
816	3/4
817	1
818	1-1/4
819	1-1/2
820	2
821	2-1/2
822	3
824-TB	3-1/2
823	4

UL not applicable

Rigid and Intermediate Metal Conduit Fittings

Plug, Conduit, Connectors (Push-Penny® Plugs)

Application

- To plug open end of conduit or fitting in order to prevent ingress of trash, dirt or moisture during construction and remodeling

Features

- Wide range of application; can be used with rigid metal conduit, intermediate metal conduit, electrical metallic tubing, all connectors and all bushings
- Designed to stand up to normal handling and is functionally unaffected by moisture

Standard Material

Polyethylene

Standard Finish

As molded

Conformity

CSA C22.2 No. 18

ANSI C80.4

NFPA 70-2008 (ANSI)

NEMA FB-1

CEC Rule: 12-3024

“Unused openings in boxes, cabinets and fittings shall be effectively closed by plugs or plates affording protection substantially equivalent to that of the wall of the box, cabinet or fittings.”

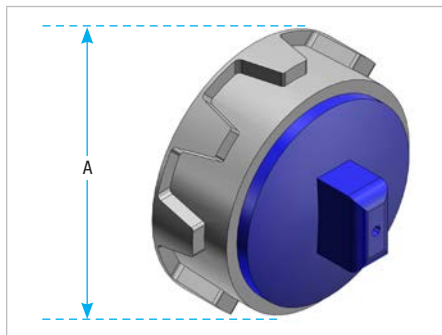

Bushings and Push-Penny® Plugs



Cat. No.	Size (in.)	A (in.)	Assembly consist of	
			Bushing	Push-Penny
1460	1/2	1-1/32	122	1470-TB
1461	3/4	1-9/32	123	1471
1462	1	1-19/32	124	1472
1463	1-1/4	1-15/16	125	1473
1464	1-1/2	2-3/16	126	1474
1465*	2	2-21/32	127	1475

* Maleable Iron
Available in Aluminum
Add suffix **AL** to Cat. No.

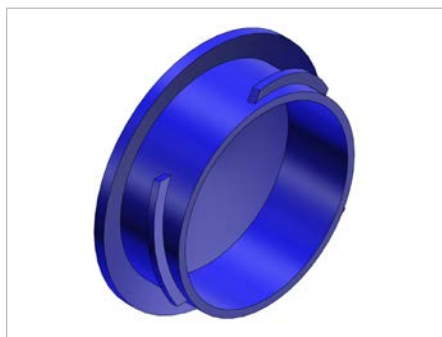

Push-Penny® Plugs



Cat. No.	Size (in.)
1470-TB	1/2
1471	3/4
1472	1
1473	1-1/4
1474	1-1/2
1475	2
1476*	2-1/2
1477*	3
1478*	3-1/2
1479*	4

*Not CSA Certified
UL not applicable

Rigid and Intermediate Metal Conduit Fittings

Application

- To effectively bush factory or field-punched, cut, or drilled holes in metal boxes or enclosures
- To couple boxes back-to-back

Features

- Rugged construction
- Insulator curled over to: Bush conductors entering/leaving at any angle. Reduce wire pull effort. Protect threads against damage in handling

Standard Material

1942 Series

Body 1/2 in.-Steel
3/8 in., 3/4 in. through 6 in. - Malleable Iron

Insulator Nylon

842AL Series All Copper-free Aluminum (less than 0.4% copper)

1942 Series Electro-zinc Plated & Chromate Coated

842AL Series Degreased

Range 1942 & 842AL Series

1/2 in. through 6 in.
All hub threads straight pipe (NPS)

Conformity

UL 514B
CSA C22.2 No. 18.3
Federal Specification W-F-408
ANSI C80.4
NFPA 70-2008 (ANSI)
NEMA FB-1
Federal Standard H-28 (Threads)

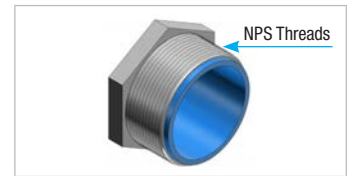

1942 Series
842AL Series
(Non Insulated)

Standard Fini

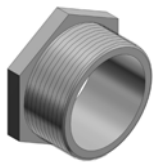

Steel, malleable iron or aluminum

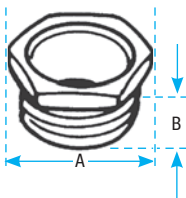

CHASE® Nipples



Cat. No. Stl. or M.I.	Alum.	Size (in.)	Dimensions (in.)	
			A	B
841TB	—	3/8	13/16	7/16
842TB	842ALTB†	1/2	15/16	11/32
843TB	843ALTB	3/4	1-3/16	11/32
844	844AL†	1	1-7/16	21/32
845	845AL†	1-1/4	1-3/4	3/4
846	846AL	1-1/2	2-1/16	13/16
847	847AL	2	2-1/2	31/32
848	848AL	2-1/2	3-1/16	1-1/16
849	849AL	3	3-13/16	1-3/16
850	850AL	3-1/2	4-3/8	1-5/16
851	851AL	4	4-3/4	1-5/16
853	853AL	5	5-7/8	1-5/16
854	854AL	6	6-15/16	1-3/8

† Not UL Listed
For Dura-Plate® finish, add prefix 040- to Cat. No. Consult your Regional Sales Office for details

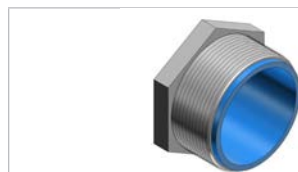

Steel or malleable iron

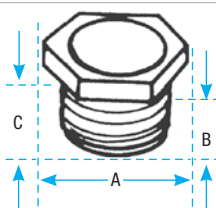

CHASE® Nipples – Nylon Insulated



Cat. No.	Size (in.)	Dimensions (in.)		
		A	B	C
1942	1/2	15/16	1/2	19/32
1943	3/4	1-3/16	17/32	23/32
1944	1	1-7/16	21/32	7/8
1945	1-1/4	1-3/4	25/32	1-1/32
1946	1-1/2	2-1/16	13/16	1-3/32
1947	2	2-9/16	31/32	1-11/32
1948	2-1/2	3-1/16	1-1/16	1-7/16
1949	3	3-13/16	1-3/16	1-19/32
1950	3-1/2	4-3/8	1-5/16	1-25/32
1951	4	4-5/8	1-5/16	1-13/16
1953	5	5-29/32	1-5/16	1-13/16
1954	6	6-13/16	1-3/8	1-7/8

Rigid and Intermediate Metal Conduit Fittings

Threaded Hubs (Bullet® Hubs) for Threaded Rigid Metal Conduit/IMC/PVC Coated Rigid Metal Conduit

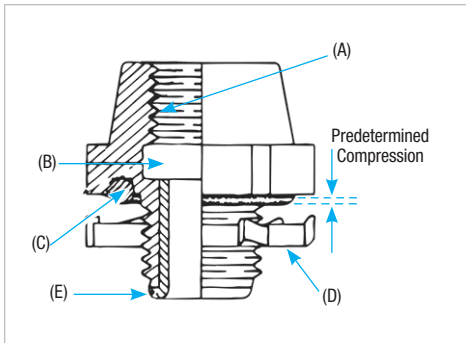

**370 Series
370AL Series**

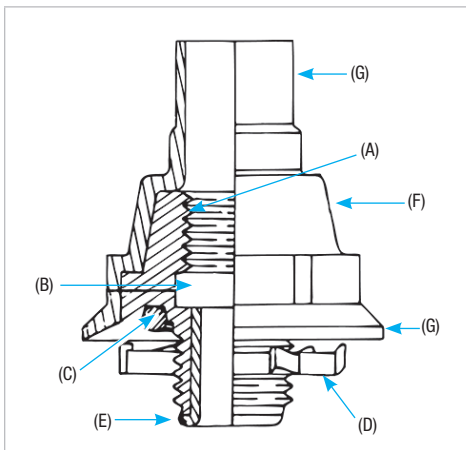

485 Series

Application

- To connect threaded metal conduit (ferrous rigid/nonferrous rigid/PVC coated/ or intermediate metal) to a threadless opening in a box or enclosure in outdoor or indoor location exposed to continuous or intermittent moisture
- To positively bond conduit to box or enclosure

Features

- Rugged steel/malleable iron/copper-free aluminum construction.
- Tapered internal threads for watertight/ dust tight union (A)
- Threads relieved to prevent bottoming of conduit ensuring sound assembly (B)
- Recessed sealing ring at box end. Captive sealing ring (C)
- Hardened steel/malleable iron/copper-free aluminum locknuts designed to provide high quality ground continuity; extended reach of locknut permits clamping on thin boxes and enclosures (D)
- Insulated throat protects conductors, prevents abrasion and thinning of conductor insulation, reduces wire pull effort (E)
- Suitable for hazardous location use per following:
 - (1) Class II, Division 1 Groups E, F, G, CEC Rule 18-202
 - Class II, Division 2 Groups E, F, G, CEC Rule 18-252
 - Class III, Division 1 Rule 18-302
 - Class III, Division 2 Rule 18-352

- PVC coated 485 Series

- (1) Protects fitting from extremely corrosive surroundings without affecting integrity of electrical grounding path (F)
- (2) Provided with overlapping sleeve for additional seal (G)

Canadian Electric Code Rule 10-602 states that, "Where **dissimilar metals** cannot be avoided at bonding connections as indicated in Rule 2-112 (2). Connections shall be made using methods or material that will minimize deterioration from galvanic action".

Joint Industrial Council (JIC) Electrical Standards also forbid dissimilar metals in contact for the same reason and require that the fittings for metal conduit be of malleable iron or ductile iron and have impact strength comparable to that of the conduit.

"Copper-free Aluminum"

- Copper-free aluminum castings for fittings have a maximum of 0.4% copper. The most detrimental effect of higher percentage of copper on aluminum base alloy is its decrease in corrosion resistance.

Rigid and Intermediate Metal Conduit Fittings

Threaded Hubs (Bullet® Hubs) for Threaded Rigid Metal Conduit/IMC/PVC Coated Rigid Metal Conduit (cont'd)

Standard Material

	370-485 Series	370AL Series
Body	1/2 in. thru 1 in. Steel 1-1/4 in. thru 6 in. Malleable Iron	All Copper-Free Aluminum
Locknut	1/2 in. thru 2 in. Steel (hardened) 2-1/2 in. thru 6 in. Malleable Iron	1/2 in. thru 2 in. Steel (hardened) 2-1/2 in. thru 4 in. Copper-free Aluminum
Screws	Steel (hardened)	
'O' Ring	Buna N	
Insulator	Nylon	
Coating	PVC	

Standard Finish

	370 Series	370AL Series	485 Series
Hub	Electro-zinc Plated	As Cast Chromate Coated	PVC — Outside Electro-zinc
Locknuts	All Ferrous locknuts Electro-Zinc Plated and Chromate Coated		Plated Chromate Coated-Inside
Screws	All Electro-Zinc Plated & Chromate Coated		

Range

370 Series	1/2 in. thru 6 in. Conduit
370AL & 485 Series	1/2 in. thru 4 in. Conduit All hub threads — straight pipe All female threads — taper pipe (NPT)

Conformity

<ul style="list-style-type: none"> UL 514B CSA 22.2 No. 18.3 ANSI C80.4 NFPA 70-2008 (ANSI) NEMA FB-1 JIC EGP1; JIC EMP 1 Federal Specification W-F-408 Federal Standard H-28 (Threads)

Rigid and Intermediate Metal Conduit Fittings



Nylon insulated

Aluminum, steel, or malleable iron (steel through 1 in.). With Neoprene "O" Ring provides a watertight threaded hub on enclosures. UL Listed 105°C.

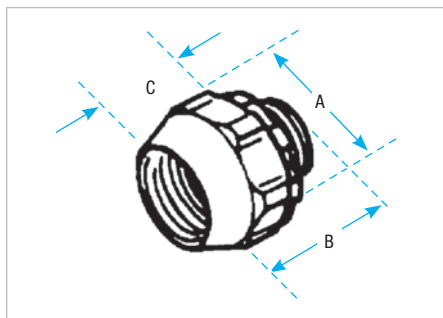

Steel/Malleable Iron and Aluminum Hub Fittings†



Cat. No.	Stl. or M.I.	Alum.**	Size (in.)	Dimensions (in.)			Wall Thk. Max. (in.)
				A	B	C	
370		370AL	1/2	1-3/8	1-5/16	3/4	5/16
371		371AL	3/4	1-5/8	1-3/8	7/8	
372		372AL	1	2-3/32	1-23/32	1-7/32	
373		373AL	1-1/4	2-9/16	2	1-11/32	
374		374AL	1-1/2	3-3/32	2	1-11/32	
375		375AL	2	3-5/8	1-31/32	1-11/32	
376		—	2-1/2	4-1/8	2-21/32	1-15/16	
377		—	3	5	2-31/32	2	1/2
378		—	3-1/2	5-9/16	3-1/8	2-1/8	
379-TB		—	4	6-9/16	3-1/8	2-1/8	
381-TB		—	5	8	4	2-3/16	
382-TB		—	6	9-3/16	4	2-3/16	

** Aluminum not available with insulated throat

† UL Listed raintight and CSA Certified watertight and dust tight

For Dura-Plate® finish, add prefix 040- to Cat. No. Consult your Regional Sales Office for details

Bullet® Hub Fittings with Bonding Locknut – Nylon Insulated



Cat. No.	Size (in.)	Description
401	1/2	Available in steel or malleable iron Supplied with 106 Series bonding nut. Temperature rating: 105°C.
402	3/4	
403-TB	1	
407	2-1/2	
408	3	
409	3-1/2	
410-TB	4	

CSA certified watertight and dust tight

Rigid and Intermediate Metal Conduit Fittings



Steel or malleable iron (steel thru 1-1/4 in.)

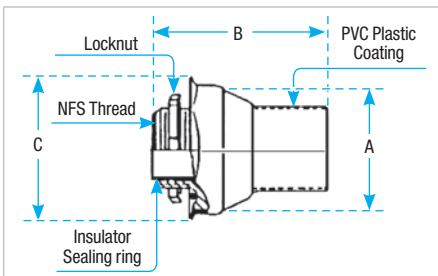

PVC Coated Hub for Rigid Conduit



Cat. No.	Size (in.)	Dimensions (in.)		
		A	B	C
485	1/2	1-21/64	2-1/8	1-7/8
486	3/4	1-19/32	2-3/8	2-1/8
487	1	1-27/32	2-3/4	2-3/8
488	1-1/4	2-15/32	3-3/8	3-1/8
489	1-1/2	2-29/32	3-5/8	3-1/2
490	2	3-3/8	3-3/4	4
491	2-1/2	3-27/32	4	4-1/2
492	3	4-21/32	4-5/8	5-3/8
493	3-1/2	5-9/64	4-13/16	5-7/8
494	4	5-3/4	4-9/16	6-7/16

*485 Series are CSA Certified Watertight and Dusttight for Ordinary Locations

Spacing Chart for Bullet® Hubs



	Center to Center Spacing Conduit Sizes (in.)										Min. Space from Center of Bullet® Hub to Wall of Box (in.)	KO Diameter Min. (in.)
	1/2	3/4	1	1-1/4	1-1/2	2	2-1/2	3	3-1/2	4		
1/2	1-7/16	1-5/8	1-3/4	2-1/8	2-3/8	2-5/8	2-7/8	3-5/16	3-1/2	3-7/8	3/4	7/8
3/4	—	1-3/4	1-7/8	2-1/4	2-1/2	2-3/4	3	3-1/2	3-3/4	4-1/8	7/8	1-1/8
1	—	—	2	2-3/8	2-5/8	2-7/8	3-1/8	3-5/8	3-7/8	4-1/4	1-1/8	1-3/8
1-1/4	—	—	—	2-11/16	2-15/16	3-1/4	3-1/2	4	4-1/4	4-1/2	1-3/8	1-3/4
1-1/2	—	—	—	—	3-1/8	3-1/2	3-3/4	4-1/8	4-3/8	4-3/4	1-5/8	2
2	—	—	—	—	—	3-3/4	4	4-1/2	4-3/4	5	1-7/8	2-1/2
2-1/2	—	—	—	—	—	—	4-1/4	4-3/4	5	5-3/8	2-1/8	3
3	—	—	—	—	—	—	—	5-1/8	5-3/8	5-3/4	2-5/8	3-5/8
3-1/2	—	—	—	—	—	—	—	—	5-5/8	6	2-7/8	4-1/8
4	—	—	—	—	—	—	—	—	—	6-1/4	3-1/4	4-5/8

T&B® Hub Centerline Spacing Chart



Conduit Trade Size (in.)	1/2 (in.)	3/4 (in.)	1 (in.)	1-1/4 (in.)	1-1/2 (in.)	2 (in.)	2-1/2 (in.)	3 (in.)	3-1/2 (in.)	4 (in.)	5 (in.)	6 (in.)
1/2	1-9/16											
3/4	1-43/64	1-25/32										
1	1-27/32	1-61/64	2-1/8									
1-1/4	2-1/32	2-9/64	2-5/16	2-1/2								
1-1/2	2-7/32	2-21/64	2-1/2	2-11/16	2-7/8							
2	2-15/32	2-37/64	2-3/4	2-15/16	3-1/8	3-3/8						
2-1/2	2-23/32	2-53/64	3	3-3/16	3-3/8	3-5/8	3-7/8					
3	3-1/32	3-9/64	3-5/16	3-1/2	3-11/16	3-15/16	4-3/16	4-1/2				
3-1/2	3-11/32	3-21/64	3-5/8	3-13/16	4	4-1/4	4-1/2	4-13/16	5-1/8			
4	3-19/32	3}	3-7/8	4-1/16	4-1/4	4-1/2	4-3/4	5-1/16	5-3/8	5-5/8		
5	4-9/32	3-25/64	4-9/16	4-3/4	4-15/16	5-3/16	5-7/16	5-3/4	6-1/16	6-5/16	7	
6	4-11/16	4-51/64	4-31/32	5-5/32	5-11/32	5-19/32	5-27/32	6-5/32	6-15/32	6-23/32	7-13/32	7-13/16
Nearest obstruction to center of hub												
	27/32	61/64	1-1/8	1-5/16	1-1/2	1-3/4	2	2-5/16	2-5/8	2-7/8	2-9/16	3-31/32

Rigid and Intermediate Metal Conduit Fittings

The T&B® Hub

Never before has a single hub fit like this one. Designed for unequalled performance. The innovative engineering of the T&B® Hub will, quite simply, raise your performance expectations for threaded hubs. The revolution in hub design is here, and the fate of our competition is sealed.

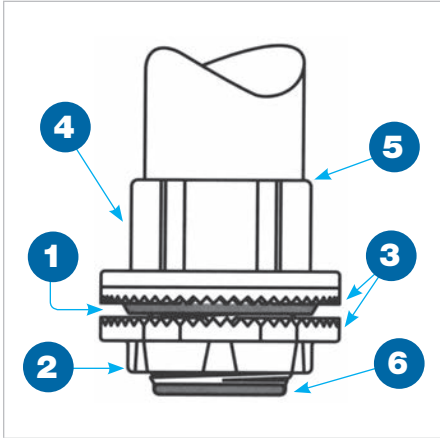

1. Sealing ring and groove with innovative profile outperforms standard 'O' ring design. Sealing ring is captive before installation and resists buckling or slipping during installation. The seal groove is designed for optimum compression of the sealing ring. The sealing ring is designed to provide a complete 360° seal, even when the conduit is not perpendicular with the enclosure. (See Figure 1)

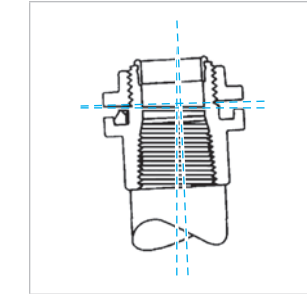

Figure 1

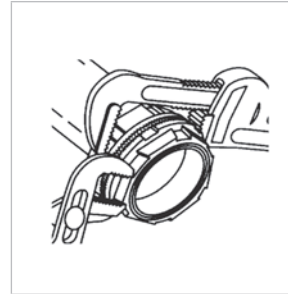

Figure 2

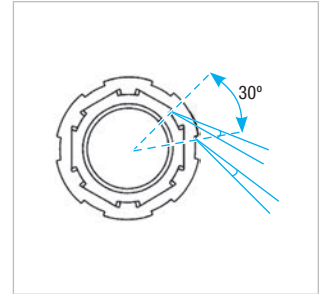

Figure 3

2. Locknut design with peripheral slots and a hexagonal/angled spline spaced every 30° enables easy application of torque with wrench or hammer and screwdriver. (See Figures 2 & 3)

3. Sharper and deeper teeth on locknut and body designed for a more penetrating bite for improved bonding to the enclosure.

4. Hexagonal / splined body design for fast, easy installation with wrench or hammer and screwdriver.

5. Precision machined tapered threads designed to create watertight union.

6. Insulated throat molded from 105°C rated thermoplastic with a flammability rating of 94V-0.

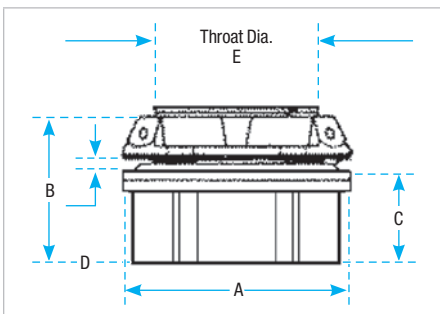

T&B® Hub



Cat. No. Zinc	Cat. No. Aluminum	Trade Size (in.)	Dia. (in.)			Max. Panel Thickness D (in.)	Throat Dia. E (in.)
			A	B	C		
H050-TB	H050A	1/2	1-7/16	1-9/16	7/8	3/16	19/32
H075-TB	H075A	3/4	1-21/32	1-19/32	29/32		25/32
H100-TB	H100A	1	2	1-13/16	1-1/16	1/4	1
H125-TB	H125A	1-1/4	2-3/8	1-7/8	1-1/16		1-5/16
H150-TB	H150A	1-1/2	2-3/4	1-7/8	1-1/16		1-17/32
H200-TB	H200A	2	3-1/4	1-15/16	1-5/32		1-31/32
H250-TB	H250A	2-1/2	3-3/4	2-9/16	1-9/16		2-13/32
H300-TB	H300A	3	4-3/8	2-21/32	1-19/32		2-31/32
H350-TB	H350A	3-1/2	5	2-23/32	1-5/8		3-13/32
H400-TB	H400A	4	5-1/2	2-23/32	1-5/8		3-7/8
H500-TB	H500A	5	6-7/8	3-1/32	1-15/16		4-15/16
H600-TB	H600A	6	7-11/16	3-5/32	2		6

Material – Hub and Locknut: zinc or copper free aluminum
 Insulating Throat: thermoplastic temp. rating 105°C, Flammability Rating: 94V-0
 Sealing Ring: Nitrile (BUNA "N")

For Chrome Plated Hubs add suffix **CP** (i.e. H050CP).
 Meets NEMA sealing requirements for NEMA 3R, 4 & 13 enclosures.
 U.L. Listed and CSA Certified. CSA Certified use in hazardous locations Class I, Division 2, Class II, Groups E, F and G, Class III, Division 1, 2 and Type 4.
 Chrome Plated Hubs (suffix-"CP") are rated NEMA 4X.
 For Aluminum Hubs add suffix **A** (i.e. H050A).

Rigid and Intermediate Metal Conduit Fittings

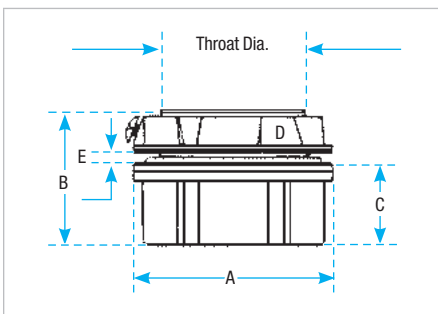

T&B Grounding Hub



Cat. No. Zinc	Cat. No. Aluminum	Trade Size (in.)	Dimensions (in.)				
			Dia. (in.)			D Max. Panel Thickness	E Throat Dia.
			A	B	C		
H050GR-C	H050GRA-C	1/2	17/16	19/16	7/8	3/16	19/32
H075GR-C	H075GRA-C	3/4	12-1/32	1-19/32	29/32	3/16	25/32
H100GR-C	H100GRA-C	1	2	1-13/16	1-1/16	1/4	1
H125GR-C	H125GRA-C	1-1/4	2-3/8	1-7/8	1-1/16	1/4	1-5/16
H150GR-C	H150GRA-C	1-1/2	2-3/4	1-7/8	1-1/16	1/4	1-17/32
H200GR-C	H200GRA-C	2	3-1/4	1-15/16	1-15/32	1/4	1-31/32
H250GR-C	H250GRA-C	2-1/2	3-3/4	2-9/16	1-9/16	1/4	2-13/32
H300GR-C	H300GRA-C	3	4-3/8	2-21/32	1-19/32	1/4	2-31/32
H350GR-C	H350GRA-C	3-1/2	5	2-23/32	1-5/8	1/4	3-13/32
H400GR-C	H400GRA-C	4	5-1/2	2-23/32	1-5/8	1/4	3-7/8
H500GR-C	H500GRA-C	5	6-7/8	3-1/32	1-15/16	1/4	4-15/16
H600GR-C	H600GRA-C	6	7-11/16	3-5/32	2	5/16	6

Material—Hub and Locknut: zinc or copper-free aluminum
 Insulating Throat: thermoplastic temp. rating 105°C;
 flammability rating: 94V-0
 Sealing Ring: Nitrile (BUNA "N")

For Chrome Plated Hubs add suffix **CP** (i.e. H050GRCP)
 For 316 Stainless Steel Hubs add suffix **SST** (i.e. H050GRSST)
 For PVC coating add suffix **PVC** (i.e. H050GRPVC-C)
 Meets NEMA sealing requirements for NEMA 3R, 4 & 13 enclosures
 UL Listed and CSA Certified
 CSA approved for use in hazardous locations: Class I, Division 2, Class II, Divisions 1 & 2, Groups E, F & G, Class III, Division 1, 2 and Type 4.



Grounding Locknut for Hubs

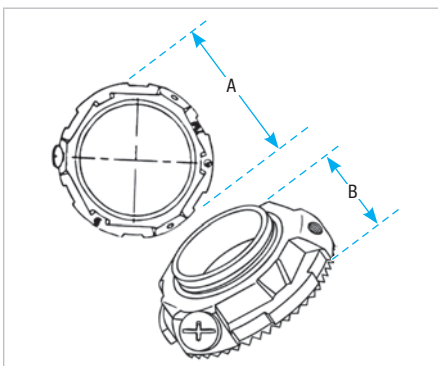

T&B Grounding and Bonding Locknut



Cat. No. with Lay-In Lug	Cat. No. without Lay-In Lug	Trade Size (in.)	A Dia. (in.)	B Height (in.)	Ground Screw (in.)	Max. Conductor Size
L050GRL	L050GR-C	1/2	1-1/2	13/32	#10-32 x 1/4	#10
L075GRL	L075GR-C	3/4	1-11/16	13/32	#10-32 x 1/4	#10
L100GRL	L100GR-C	1	2	13/32	#10-32 x 1/4	#10
L125GRL	L125GR-C	1-1/4	2-3/8	15/32	1/4-20 x 1/4	#10
L150GRL	L150GR-C	1-1/2	2-3/4	15/32	1/4-20 x 5/16	#8
L200GRL	L200GR-C	2	3-1/4	15/32	1/4-20 x 5/16	#8
L250GRL	L250GR-C	2-1/2	3-3/4	11/16	1/4-20 x 5/16	#6
L300GRL	L300GR-C	3	4-3/8	23/32	1/4-20 x 5/16	#6
L350GRL	L350GR-C	3-1/2	5	23/32	1/4-20 x 5/16	#6
L400GRL	L400GR-C	4	5-1/2	23/32	1/4-20 x 5/16	#4
L500GRL	L500GR-C	5	6-5/8	23/32	3/8-16 x 3/8	#2

Material — Locknut: zinc or copper-free aluminum
 For Aluminum Locknuts add suffix **A**. (i.e. L050GRA-C)
 For Chrome Plated Locknuts add suffix **CP**. (i.e. L050GR-CP)
 For 316 Stainless Steel Locknuts add suffix **SST**. (i.e. L050GRSST).





Rigid and Intermediate Metal Conduit Fittings

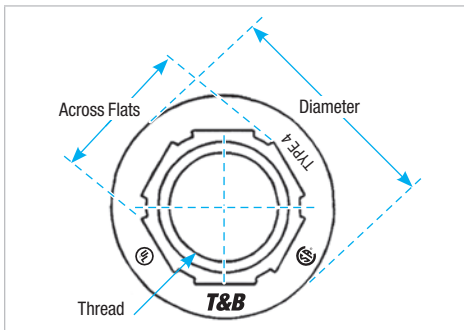

T&B Bulkhead Fittings

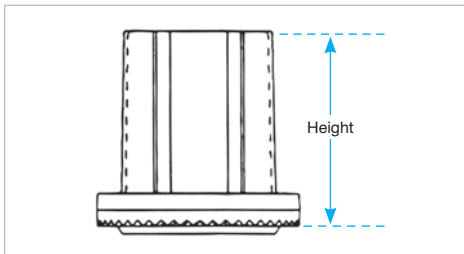

Bulkhead Fitting		
Cat. No. Zinc	Cat. No. Aluminum	Trade Size (in.)
H050BHD	H050BHDA	1/2
H075BHD	H075BHDA	3/4
H100BHD	H100BHDA	1
H125BHD	H125BHDA	1-1/4
H150BHD	H150BHDA	1-1/2
H200BHD	H200BHDA	2
H250BHD	H250BHDA	2-1/2
H300BHD	H300BHDA	3
H350BHD	H350BHDA	3-1/2
H400BHD	H400BHDA	4
H500BHD	H500BHDA	5
H600BHD	H600BHDA	6

Thru Bulkhead Fitting		
Cat. No. Zinc	Cat. No. Aluminum	Size (in.)
H050TBF	H050TBFA	1/2
H075TBF	H075TBFA	3/4
H100TBF	H100TBFA	1
H125TBF	H125TBFA	1-1/4
H150TBF	H150TBFA	1-1/2
H200TBF	H200TBFA	2

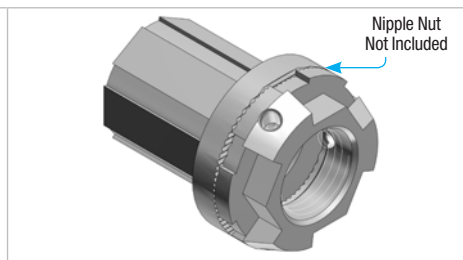
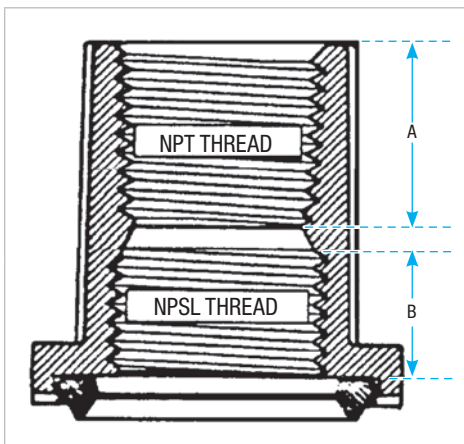
Thru Bulkhead Hub		
Cat. No. Zinc	Cat. No. Aluminum	Size (in.)
H050TBH	H050TBHA	1/2
H075TBH	H075TBHA	3/4
H100TBH	H100TBHA	1
H125TBH	H125TBHA	1-1/4
H150TBH	H150TBHA	1-1/2
H200TBH	H200TBHA	2

Trade Size (in.)	Thread (in.)	Height (in.)	Diameter (in.)	Across Flats (in.)	A (in.)	B (in.)
1/2	1/2-14	1-13/32	1-7/16	1	3/4	1/2
3/4	3/4-14	1-15/32	1-11/16	1-1/4	25/32	17/32
1	1-11-1/2	1-11/16	2	1-17/32	29/32	19/32
1/4	1-1/4-11-1/2	1-25/32	2-3/8	1-27/32	29/32	21/32
1-1/2	1-1/2-11-1/2	1-13/16	2-3/4	1-1/8	29/32	21/32
2	2-1-1/2	1-27/32	3-1/4	2-5/8	15/16	21/32
2-1/2	2-1/2-8	29/32	3-3/4	3-1/8	17/32	7/8
3	3-8	2-9/16	4-3/8	3-25/32	15/16	29/32
3-1/2	3-1/2-8	2-9/16	5	4-9/32	1-3/8	7/8
4	4-8	2-9/16	5-1/2	4-27/32	1-3/8	7/8
5	5-8	2-23/32	6-5/8	5-29/32	1-15/32	7/8
6	6-8	3	7-11/16	7-1/32	1-1/2	31/32

Material— Hub, Body and Locknut: zinc or copper-free aluminum
 Insulating Throat: thermoplastic temp. rating 105°C; Flammability rating: 94V-0
 Sealing Ring: Nitrile (BUNA "N")
 For Chrome Plated Bulkhead add suffix **CP**

Rigid and Intermediate Metal Conduit Fittings

T&B XD Expansion/Deflection Coupling for Rigid Conduit

Watertight, flexible connections support movement and thermal expansion

Use the XD Expansion/Deflection Coupling to join two conduit runs in applications where movement in any direction is required. The coupling provides a flexible, watertight connection, accommodating axial or parallel movement of up to 3/4 in. and angular movement of up to 30° from normal position. While similar fittings exist on the market today, this new and enhanced XD Expansion/Deflection Coupling ships complete with an Erickson® conduit union to significantly reduce installation time and effort and includes a stainless steel inner sleeve for extreme durability, protection and easier wire pulling.

The hubs are zinc-plated and then coated with aluminum acrylic paint for dual-layer corrosion protection. In addition, the copper ground mounting plates and internal grounding bonding jumper are entirely enclosed inside the coupling for added security against vandalism and theft.

- Accommodates axial expansion/contraction up to 3/4 in., parallel deflection up to 3/4 in. and angular misalignment up to 30°
- Suitable for use indoors, outdoors, direct buried or embedded in concrete
- Watertight, flexible neoprene outer jacket, zinc-plated and acrylic-painted hubs and stainless steel tamper-proof straps ensure superior corrosion resistance — ideal for use in harsh environments
- Copper ground mounting plates and internal grounding bonding jumper both entirely enclosed to safeguard against theft
- Includes an Erickson® conduit union for faster, easier installation to reduce labor costs
- Durable stainless steel inner sleeve provides a constant, smooth inner diameter in any position to ease wire pulling and protect wire insulation from damage
- NPT threaded hubs fit standard threaded rigid metal conduit
- Can also be used with rigid PVC conduit with the use of standard adapters (not supplied)

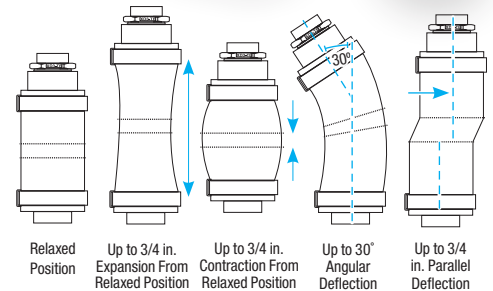
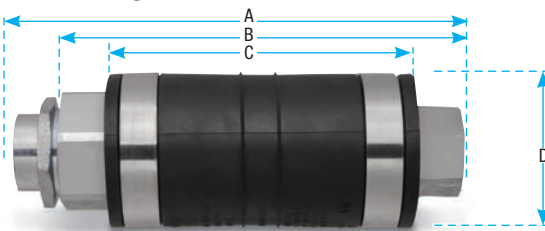

Standard Material/Finish

- Hub** Ductile cast iron, zinc-plated and aluminum acrylic painted
- Inner Sleeve** Stainless Steel
- Internal Grounding Bonding Jumper** Flexible copper braid
- Ground Mounting Plates** Copper
- Hub Rings** Zinc-plated steel
- Outer Jacket** Molded neoprene (natural black)
- Jacket Straps** Stainless Steel



Cat. No.	Hub Size (in.)	Dimensions (in.)			
		A	B	C	D
XD3-TB	1	9-13/16	8-15/32	6-7/16	3-11/32
XD4-TB	1-1/4	9-3/16	8-3/8	6-7/8	3-7/8
XD5-TB	1-1/2	9-1/4	8-7/32	6-3/4	4-5/32
XD6-TB	2	9-3/4	8-21/32	7-1/4	4-11/16
XD7-TB	2-1/2	11-3/4	11-3/8	8-1/2	4-7/8
XD8-TB	3	10-1/2	9-21/32	7-21/32	5-15/16
XD9-TB	3-1/2	10-9/16	9-3/4	7-3/4	6-5/8
XD010-TB	4	13-3/16	11-27/32	8-7/8	7-9/32
XD012-TB	5	14	12-15/16	11	8-9/32
XD014-TB	6	14-5/16	13-3/8	11-3/8	9-19/32

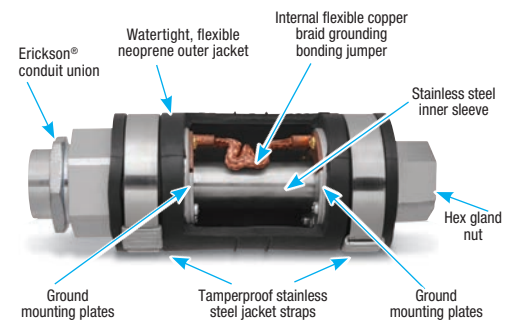

Certifications/Compliances

- CSA Certified to C22.2 and UL Listed to UL 514B No. 18 Suitable for Wet Locations (hub sizes 1 in.–2-1/2 in.)
- Watertight
- NEC Article 250.98 compliant

Rigid and Intermediate Metal Conduit Fittings

T&B XJG Conduit Expansion Couplings for Rigid Conduit

Easy to Install — Save Time and Money on the Job
No Disassembly Required!

Suggested Specifications for expansion fittings for rigid steel or Intermediate Metal Conduit

Used where:

- Raceways require expansion fittings to compensate for thermal expansion and contraction.
- Expansion fittings and telescoping sections of metal raceway must be made electrically continuous by bonding jumpers or other means

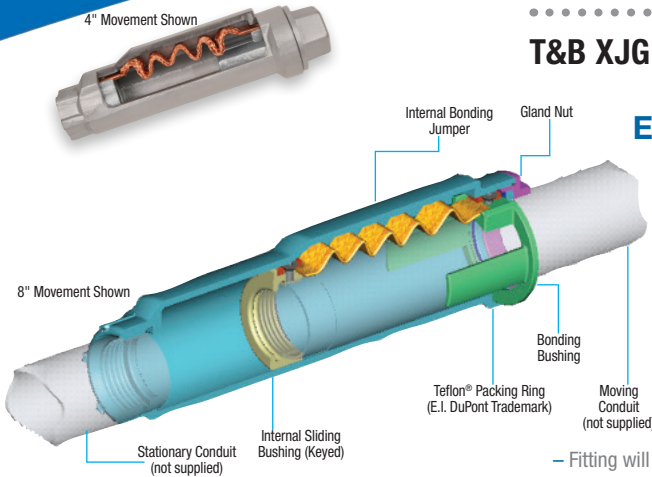

- Fitting will be constructed from cast iron with exterior and interior zinc plating for corrosion protection
- The fitting shall be constructed so that disassembly is not required during installation
- Fitting shall be raintight after installation
- The fitting shall have an internal bonding jumper constructed of a copper braid, sized to meet UL fault current test requirements and comply with bonding requirements — CEC article 10-612 and 10-614
- External bonding jumper shall not be required to comply with CEC requirements
- Accepted Manufacturer: Thomas & Betts — XJG-TB Series

Standard Material/Finish

Body Malleable or Ductile Iron, available PVC Coated

Internal Bonding Jumper Copper Braid

Exterior and Interior Finish Zinc plating, aluminum acrylic paint

Packing PTFE/Synthetic fiber Material (Teflon® Coated)

Teflon® is a trademark of DuPont.

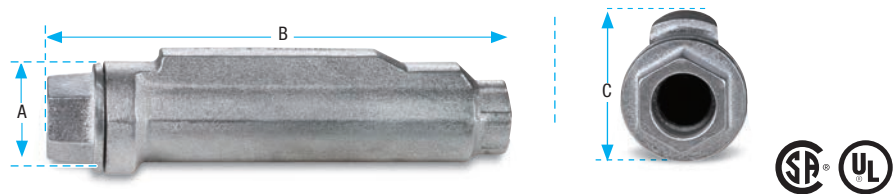

1 Slide the fitting onto the conduit until it stops at the internal sliding bushing. Tighten and you're ready. No parts to reassemble!



2 With a wrench, tighten the gland nut to compress the Teflon® packing, creating a raintight seal around the conduit.



3 Thread the next length of conduit into the other end of the fitting and tighten. You're done!

Cat. No.	Size (in.)	Movement (in.)	Dimensions (in.)		
			A	B	C
XJG24-TB	3/4	4	2.43	10.00	2.75
XJG28-TB	3/4	8	2.43	14.00	2.75
XJG34-TB	1	4	2.67	10.00	2.99
XJG38-TB	1	8	2.67	14.00	2.99
XJG44-TB	1-1/4	4	3.36	10.56	3.68
XJG48-TB	1-1/4	8	3.36	14.56	3.68
XJG54-TB	1-1/2	4	3.36	10.56	3.68
XJG58-TB	1-1/2	8	3.36	14.56	3.68
XJG64-TB	2	4	3.86	11.25	4.18
XJG68-TB	2	8	3.86	15.25	4.18
XJG74-TB	2-1/2	4	4.96	12.12	5.25
XJG78-TB	2-1/2	8	4.96	16.12	5.25
XJG84-TB	3	4	4.96	12.12	5.25
XJG88-TB	3	8	4.96	16.12	5.25
XJG94-TB	3-1/2	4	6.37	12.87	6.75
XJG98-TB	3-1/2	8	6.37	16.87	6.75
XJG104-TB	4	4	6.37	12.87	6.75
XJG108-TB	4	8	6.37	16.87	6.75
XJG1208-TB	5	8	7.99	18.87	8.56

Also available in PVC Ocal™ coating and for EMT.

Rigid and Intermediate Metal Conduit Fittings

T&B XJG-EMT Conduit Expansion Couplings for EMT

Features

- Fast and easy installation — no disassembly required
- No external grounding strap needed — internal bonding jumper is protected from tampering and the environment

Standard Material/Finish

Body Malleable or ductile iron
Internal Bonding Jumper Tinned copper braid
Exterior and Interior Finish Zinc plating, aluminum acrylic paint
Packing PTFE/Synthetic fiber material

Certifications/Compliances

- CSA Certified to C22.2 and UL Listed to UL 514B No. 18 Suitable for Wet Locations (hub sizes 1 in.–2-1/2 in.)
- NEC Article 250.98 compliant

Note: XJG-EMT couplings are not raintight and are for use in dry locations only. They are UL Listed for use with aluminum EMT.

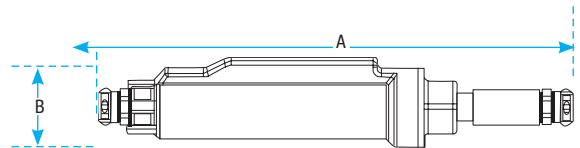

Cat. No.	Size (in.)	Movement (in.)	A (length in.)	B (height in.)
XJG24-EMT	3/4	4	17.39	2.75
XJG28-EMT	3/4	8	21.39	2.75
XJG34-EMT	1	4	17.42	2.99
XJG38-EMT	1	8	21.42	2.99
XJG44-EMT	1-1/4	4	18.27	3.46
XJG48-EMT	1-1/4	8	22.27	3.46
XJG54-EMT	1-1/2	4	18.69	3.68
XJG58-EMT	1-1/2	8	22.69	3.68
XJG64-EMT	2	4	19.04	4.18
XJG68-EMT	2	8	23.04	4.18
XJG74-EMT	2-1/2	4	23.23	4.52
XJG78-EMT	2-1/2	8	27.23	4.52
XJG84-EMT	3	4	24.09	5.25
XJG88-EMT	3	8	28.09	5.25
XJG94-EMT	3-1/2	4	28.70	6.00
XJG98-EMT	3-1/2	8	28.70	6.00
XJG104-EMT	4	4	29.30	6.75
XJG108-EMT	4	8	29.30	6.75

Rigid and Intermediate Metal Conduit Fittings

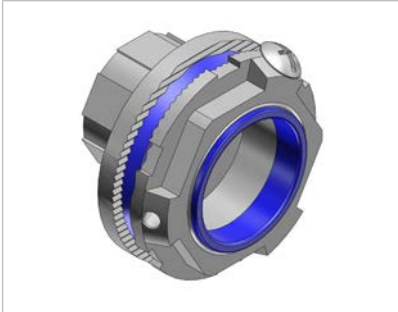

Offset Reducers



Cat. No. Zinc	Cat. No. Aluminum	Trade Size (in.)	Height (in.)	Diameter (in.)	Dimensions (in.)				
					A	B	C	D	E
H150-0750RGR-TB	H150-0750RGRA-TB	1-1/2-3/4	1-21/32	2-3/4	15/16	23/32	1-29/32	1-9/32	11/32
H150-1000RGR-TB	H150-1000RGRA-TB	1-1/2-1	1-25/32	2-3/4	1-1/16	23/32	1-29/32	1-9/16	7/32
H150-1250RGR-TB	H150-1250RGRA-TB	1-1/2-1-1/4	1-25/32	2-3/4	1-1/16	23/32	1-29/32	1-7/8	1/32
H250-2000RGR-TB	H250-2000RGRA-TB	2-1/2-2	2-1/8	3-3/4	1-3/16	15/16	2-29/32	2-21/32	3/32

Material— Offset Reducer and Locknut: zinc or copper-free aluminum
 Insulating Throat: thermoplastic temp. rating 105°C; Flammability rating 94V-0
 Sealing Ring: Nitrile (BUNA "N")

For Chrome Plated Offset Reducer add suffix **CP**. (i.e. H150-1250RGRCP-TB)

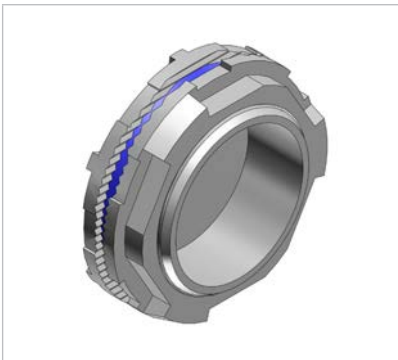
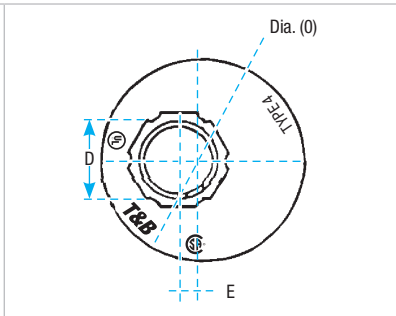
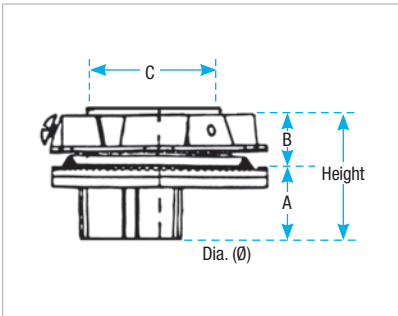

Capoffs



Cat. No. Zinc	Cat. No. Aluminum	Trade Size (in.)	Height (in.)	Diameter (in.)	Dimensions (in.)		
					A	B	C
H050CAP	H050CAPA	1/2	1-13/32	1-7/16	19/32	27/32	3/16
H075CAP	H075CAPA	3/4	1-15/32	1-11/16	19/32	1-1/16	3/16
H100CAP	H100CAPA	1	1-11/16	2	11/16	1-5/16	1/4
H125CAP	H125CAPA	1-1/4	1-25/32	2-3/8	23/32	1-21/32	1/4
H150CAP	H150CAPA	1-1/2	1-13/16	2-3/4	23/32	1-29/32	1/4
H200CAP	H200CAPA	2	1-27/32	3-1/4	23/32	2-3/8	1/4
H250CAP	H250CAPA	2-1/2	2-9/32	3-3/4	7/8	2-29/32	1/4
H300CAP	H300CAPA	3	2-9/16	4-3/8	7/8	3-1/32	11/32
H350CAP	H350CAPA	3-1/2	2-9/16	5	29/32	4-1/32	11/32
H400CAP	H400CAPA	4	2-9/16	5-1/2	29/32	4-1/2	11/32
H500CAP	H500CAPA	5	2-23/32	6-5/8	29/32	5-9/16	11/32
H600CAP	H600CAPA	6	3	7-5/8	31/32	6-5/8	11/32

Material— Capoff and Locknut: zinc or copper-free aluminum
 Insulating Throat: thermoplastic temp. rating 105°C; flammability rating 94V-0
 Sealing Ring: Nitrile (BUNA "N")
 For Chrome Plated Capoff add suffix **CP**. (i.e. H050CAPCP)

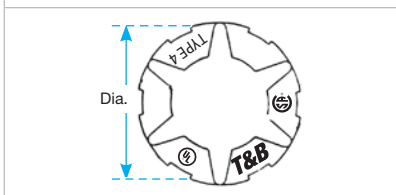
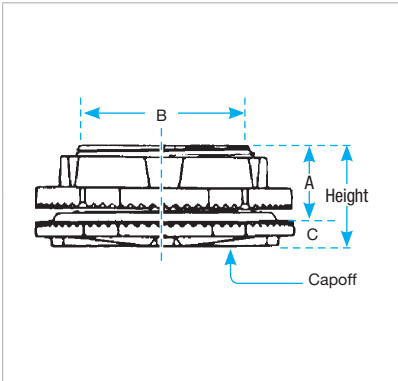

Rigid and Intermediate Metal Conduit Fittings

Threadless Fittings/Couplings for Threadless Rigid Metal Conduit and Intermediate Metal Conduit

Application

- To connect and effectively bond threadless rigid metal conduit/intermediate metal conduit to a box or enclosure, or to couple ends of threadless conduit

Features

- Steel/Malleable Iron Construction
- Case hardened ring bites into conduit for high quality continuity and grip
- Nylon insulator firmly secured in place protects conductors and reduces wire pulling effort by as much as 50%; prevents thread damage in handling
- Case hardened steel locknut or malleable iron locknut designed to provide a positive bond
- Suitable for concrete tight application
- Raintight application
- Capable of carrying ground fault currents up to 10,000 amps RMS (1/2 in. through 1-1/2 in. size) and 20,000 amps RMS (2 in. and above sizes) duration of current 3 cycles

Standard Material

Nut, Gland	1/2 in. to 1 in. Steel 1-1/4 in. to 4 in. Malleable Iron
Body	All Malleable Iron
Ring	Steel (case hardened)
Insulator	Nylon
Locknut	1/2 in. thru 2 in. Steel (hardened) 2 in. thru 4 in. Malleable Iron

Standard Finish

Electro Zinc Plated & Chromate Coated

Range

- **8123 & 8120 Series** 1/2 in. through 4 in. Size Conduit
- **8130 Series** 1/2 in. and 3/4 in. Size Conduit
- **All hub threads** Straight Pipe (NPS)

Conformity

UL 514B
CSA C22.2 No. 18.3
ANSI C80.4
NFPA 70-2008 (ANSI)
NEMA FB-1
Federal Specification W-F-408
Federal Standard H-28 (Threads)



8123 Series

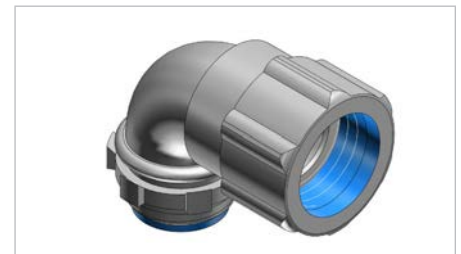

8130 Series



8120 Series

Rigid and Intermediate Metal Conduit Fittings

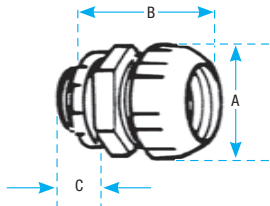

A split steel ring with diagonal serrations grips the conduit and bites into it for positive ground. Makes a permanent connection and eliminates the need for cutting a thread on the conduit. Insulation helps to guarantee continuity of service with protection of the conductor at the critical point — the fitting bushing.

Malleable iron construction.

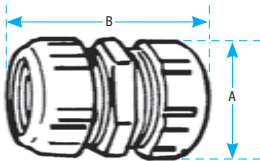

Eliminate conduit threading. When tightened with a wrench they make a UL Listed and CSA Certified concrete-tight connection

Malleable iron construction.

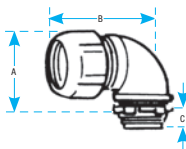
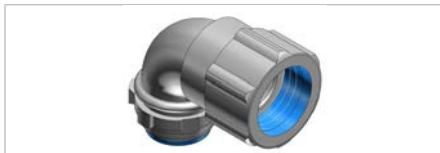

Ideal for entering enclosure or conduit body at right angles. Eliminates need to thread conduit. As with straight couplings, this fitting makes a concrete-tight connection.

Malleable iron construction.

Nylon Insulated Threadless Fittings



Cat. No.	Nylon Insul.	Conduit Size (in.)	Dimensions (in.)		
			A	B	C
8123	8121	1/2	1-11/32	1-15/16	3/4
8223	8221	3/4	1-5/8	2	3/4
8323	8321	1	1-7/8	2-7/16	7/8
8423	8421	1-1/4	2-3/8	2-9/16	11/16
8523	8521	1-1/2	2-5/8	2-3/4	3/4
8623	8621	2	3-1/4	2-15/16	27/32
8723-TB	8721	2-1/2	3-15/16	3-15/16	1-1/8
8823-TB	8821	3	4-11/16	4-1/8	1-7/32
8853	8851	3-1/2	5-3/16	4-1/4	1-1/8
8973	8971	4	5-11/16	5	1-1/8

For Dura-Plate® finish, add prefix 040- to Cat. No. Consult your Regional Sales Office for details

Threadless Couplings



Cat. No.	Size (in.)	Dimensions (in.)	
		A	B
8120	1/2	1-9/32	2
8220	3/4	1-19/32	2-5/16
8320	1	1-7/8	2-11/16
8420	1-1/4	2-3/8	2-13/16
8520	1-1/2	2-5/8	3-5/8
8620	2	3-1/4	3-13/16
8720	2-1/2	3-15/16	5-3/8
8820	3	4-11/16	5-1/2
8850	3-1/2	5-3/16	5-1/2
8970	4	5-11/16	5-1/2

For Dura-Plate® finish, add prefix 040- to Cat. No. Consult your Regional Sales Office for details

Threadless Short Elbows – Nylon Insulated



Cat. No.	Size (in.)	Dimensions (in.)		
		A	B	C
8130	1/2	1-11/32	1-1/2	1/2
8131	3/4	1-5/8	1-3/4	9/16
8132	1	1-7/8	1-15/16	11/16
8134	1-1/2	2-23/32	3-1/8	13/16

For Dura-Plate® finish, add prefix 040- to Cat. No. Consult your Regional Sales Office for details

Rigid and Intermediate Metal Conduit Fittings

Specifications — Set-Screw Fitting/Coupling for Threadless Rigid Metal Conduit and Intermediate Metal Conduit



8125 Series



8124 Series

Application

- To connect and effectively bond threadless rigid metal conduit or intermediate metal conduit to a box or enclosure or to couple ends of threadless conduit

Features

- Thickwall steel or malleable iron body
- Hardened hex head cup point screw to provide high quality bond
- Captive screw, will not vibrate loose
- Nylon insulated throat meets and exceeds all codes requirements for bushing:
 - (1) Prevents thinning of insulation
 - (2) Reduces installation effort
 - (3) Prevents first thread damage
- Coupling provided with positive center stop
- Suitable for concrete-tight application
- Capable of carrying ground fault currents up to 10,000 amps RMS (1/2 through 1-1/2 in. size) and 20,000 amps RMS (2 in. and above sizes)

Standard Material

- Body** 1/2 in. thru 2 in. Steel
2-1/2 in. thru 4 in. Malleable Iron
- Locknut** 1/2 in. thru 2 in. Steel (hardened)
2-1/2 in. thru 4 in. Malleable Iron
- Screw** Steel (hardened)

Insulator Nylon

Standard Finish

Electro Zinc Plated & Chromate Coated

Conformity

- UL 514B
- CSA C22.2 No. 18.3
- ANSI C80.4
- NFPA 70-2008 (ANSI)
- NEMA FB-1
- Federal Specification W-F-408
- Federal Standard H-28 (Threads)

Rigid and Intermediate Metal Conduit Fittings

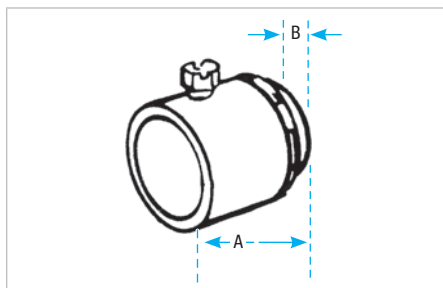

Eliminate conduit threading with these set screw fittings. Captive hex head screws tighten down onto conduit for positive holding strength and ground. The fittings are furnished with insulated throats reducing wire pulling effort by as much as 50%. Approved concrete-tight.

Insulated Set-Screw Fitting



Cat. No.	Conduit Size (in.)	Dimensions (in.)	
		A	B
8125	1/2	1-3/8	13/32
8225	3/4	1-1/2	7/16
8325	1	1-13/16	35/65
8425	1-1/4	2	5/8
8525-TB	1-1/2	2-5/16	5/8
8625	2	2-7/16	11/16
8725-TB	2-1/2	3-3/8	1
8825	3	3-7/16	1
8855	3-1/2	3-7/8	1-1/16
8975	4	4-3/16	1-1/8

Sizes 1/2 in.-2 in. made of steel. Sizes 2-1/2 in.-4 in. are malleable iron
For Dura-Plate® finish, add prefix 040- to Cat. No. Consult your Regional Sales Office for details

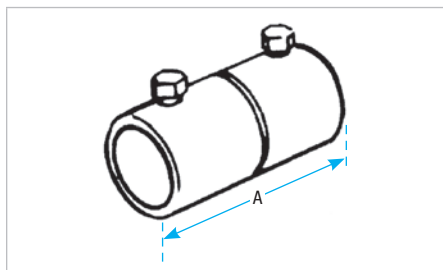

Eliminate the need for threading conduit ends when joining rigid conduit with these set screw couplings. Captive hex head screws provide positive holding strength and ground continuity. Approved concrete-tight.

Set Screw Coupling



Cat. No.	Conduit Size (in.)	Dimensions (in.)
		A
8124	1/2	2-1/2
8224	3/4	2-11/16
8324-TB	1	2-27/32
8424	1-1/4	3
8524	1-1/2	3-3/8
8624	2	3-5/8
8724-TB	2-1/2	3-7/8
8824-TB	3	4-1/4
8974	4	5-3/8

Sizes 1/2 in.-2 in. made of steel; sizes 2-1/2 in.-4 in. are malleable iron
For Dura-Plate® finish, add prefix 040- to Cat. No. Consult your Regional Sales Office for details.

Rigid and Intermediate Metal Conduit Fittings

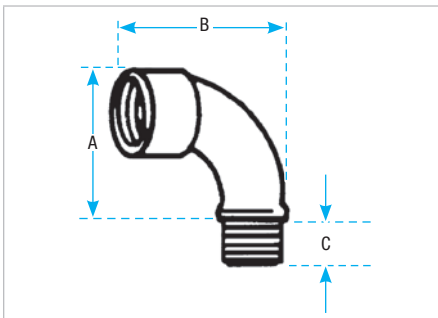

The noninsulated elbow has smoothly rounded shoulders to protect conductor insulation
Malleable iron

Bushed Elbows



Cat. No.	Size (in.)	Dimensions (in.)		
		A	B	C
460TB	1/2	1-13/16	1-1/8	5/8
461TB	3/4	2-1/4	1-1/2	9/16
462	1	2-23/32	1-23/32	11/16
463	1-1/4	3-1/8	2-1/16	25/32

For Dura-Plate® finish, add prefix 040- to Cat. No. Consult your Regional Sales Office for details

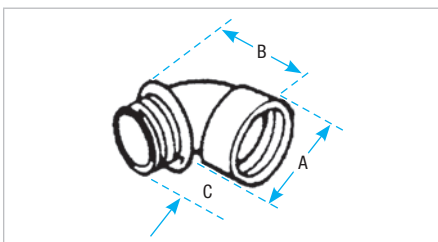
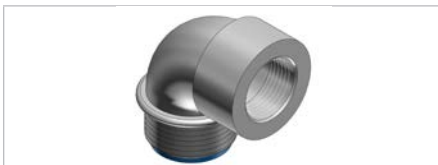

The integral insulation of the insulated elbow is a guarantee that the bushing of every fitting will be smooth
Malleable iron

Short Elbows – Nylon Insulated



Cat. No.	Size (in.)	Dimensions (in.)		
		A	B	C
4290	1/2	1-7/32	1-1/4	1/2
4291	3/4	1-7/16	1-5/16	9/16
4292	1	1-23/32	1-9/16	11/16
4293	1-1/4	2-7/32	2-1/16	13/16
4294	1-1/2	2-15/32	2-3/16	13/16

For Dura-Plate® finish, add prefix 040- to Cat. No. Consult your Regional Sales Office for details
Not UL Listed

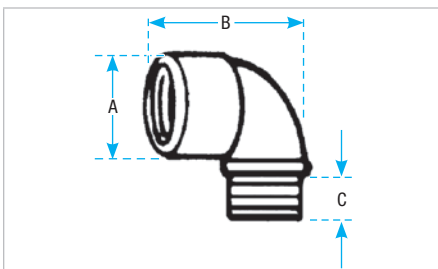

When an insulated elbow is not desired, the non-insulated short elbow should be used
Malleable iron

Short Elbows



Cat. No.	Size (in.)	Dimensions (in.)		
		A	B	C
4250	1/2	1-5/16	1-1/4	7/16
4251	3/4	1-17/32	1-5/16	1/2
4252	1	1-13/16	1-9/16	5/8
4253	1-1/4	2-9/32	2-1/16	11/16
4254	1-1/2	2-9/16	2-3/16	11/16
4255	2	3-3/32	2-9/16	11/16

For Dura-Plate® finish, add prefix 040- to Cat. No. Consult your Regional Sales Office for details

Rigid and Intermediate Metal Conduit Fittings

Threaded Couplings (ERICKSON®) Couplings for Threaded Rigid Metal Conduit and Intermediate Metal Conduit



674 Series
675AL Series

Application

- To couple and effectively bond threaded ends of rigid metal conduit/intermediate metal conduit where neither length of conduit can be rotated

Features

- Malleable Iron/Steel/Copper-free Aluminum Construction
- Free fitting threads ensure easy assembly.
- Permits conduit coupling without rotating either conduit
- Provides rigid in-line coupling with high quality grounding; will not loosen under vibration
- Suitable for concrete-tight application.
- Capable of carrying ground fault currents up to 10,000 amps RMS (1/2 in. through 1-1/2 in. size) and up to 20,000 amps RMS (2 in. and above) (duration of fault current 3 cycles) (674 Series tested)

Standard Material

674 Series

Bushing and Body Malleable Iron
Ring Steel up to 2 in. or Malleable Iron

675AL Series

Bushing and Body Aluminum
Ring Aluminum

Standard Finish

674 Series: Electro Zinc Plated & Chromate Coated

675AL Series: Degreased

Range

- 674 Series:** 3/8 in. thru 6 in. Conduit
- 675AL Series:** 1/2 in. thru 6 in. Conduit
- All straight pipe threads (NPS)

Conformity

UL 514B
CSA C22.2 No. 18.3
NEMA FB1
ANSI C80.4
NFPA 70-2008 (ANSI)
Federal Specification W-F-408
Federal Standard H-28 (Threads)

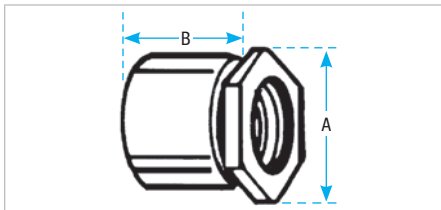
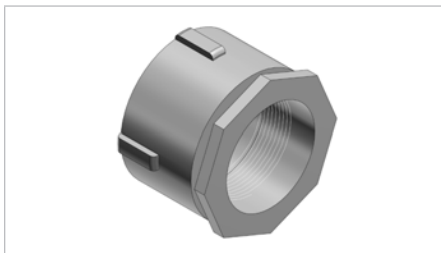

With an Erickson® coupling, a conduit run may be completed when neither conduit can be turned. A conduit run may also be broken without taking down the whole run. Conduit joined with Erickson® Couplings is rigid and in line and vibration will not loosen the connections.

ERICKSON® Couplings



Cat. No.	Alum.*	Size (in.)	Dimensions (in.)	
			A	B
674	—	3/8	1-1/8	1-1/8
675	675AL	1/2	1-15/32	1-1/4
676	676AL	3/4	1-9/16	1-13/32
677	677AL	1	1-29/32	1-5/8
678	678AL	1-1/4	2-3/8	1-13/16
679	679AL	1-1/2	2-5/8	1-31/32
680-TB	680AL	2	3-7/32	2-7/32
681	681AL	2-1/2	3-3/32	2-11/16
682	682AL	3	4-7/16	2-29/32
683	683AL	3-1/2	5	3
684	684AL	4	5-1/2	3-3/16
685	685AL†	4-1/2	6-1/4	3-15/32
686	686AL	5	6-25/32	3-3/4
687	687AL	6	8	4-1/32

* Copper-free Aluminum (less than 0.4% Copper)
UL Listed and CSA Certified concrete-tight
† Not CSA Certified

Rigid and Intermediate Metal Conduit Fittings

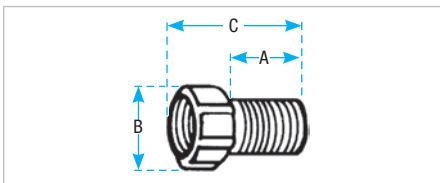
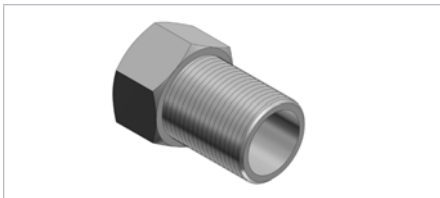

Ideal when longer thread length is needed. Will combine with any fitting having a male thread. Male thread of panel fitting extension is 1 in. long.
Malleable iron

Panel Fitting Extensions



Cat. No.	Size (in.)	Dimensions (in.)		
		A	B	C
1440	1/2	1-1/4	1-3/16	1-7/8
1441	3/4	1-1/4	1-13/32	1-15/16
1442	1	1-3/16	1-21/32	1-15/16
1443	1-1/4	1-1/4	2-1/8	2

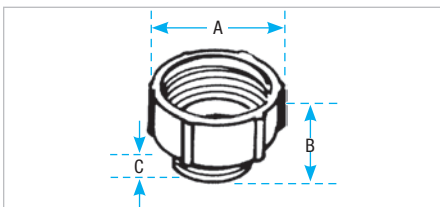
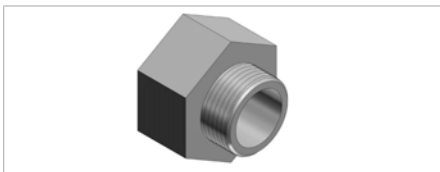

Adapt an outlet hole to the next larger size of conduit. Rough ends of conduit caarefully covered by built-in bushing.
Malleable iron

Male Enlargers



Cat. No.	Size (in.)	Dimensions (in.)		
		A	B	C
1245	1/2	1-1/4	1-3/16	1-7/8
1246	3/4	1-1/4	1-13/32	1-15/16
1244	1	1-3/16	1-21/32	1-15/16
1247	1-1/4	1-1/4	2-1/8	2

For Dura-Plate® finish, add prefix 040- to Cat. No. Consult your Regional Sales Office for details

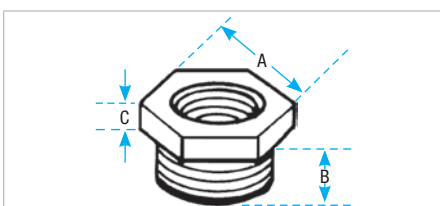
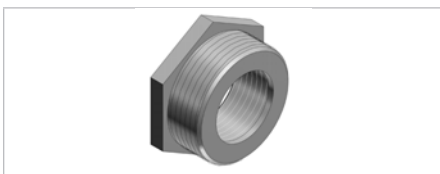

Adapt an outlet hole to the next larger size of conduit. Rough ends of conduit caarefully covered by built-in bushing.
Malleable iron

Female Reducers



Cat. No.	Size (in.)	Dimensions (in.)		
		A	B	C
1250-TB	3/4 to 1/2	1-1/8	5/8	3/16
1261	1 to 1/2	1-7/16	1-7/16	3/16
1251	1 to 3/4	1-3/8	11/16	3/16
1262	1-1/4 to 1/2	1-13/16	21/32	3/16
1263	1-1/4 to 3/4	1-13/16	23/32	3/16
1252	1-1/4 to 1	1-3/4	25/32	7/32
1253	1-1/2 to 1-1/4	2	13/16	1/4
1254	2 to 1-1/2	2-3/8	1-3/16	9/32
1255	2-1/2 to 2	3	1-1/4	3/8
1256	3 to 2-1/2	3-5/8	1-1/2	1/2
1257	3-1/2 to 3	4-1/8	1-9/16	1/2
1258	4 to 3-1/2	4-5/8	1-3/16	1/2

For Dura-Plate® finish, add prefix 040- to Cat. No. Consult your Regional Sales Office for details

Rigid and Intermediate Metal Conduit Fittings

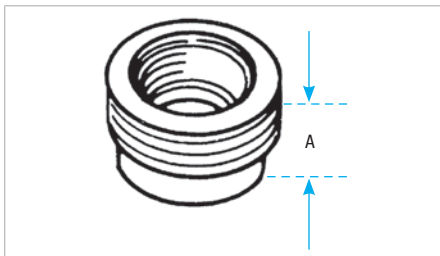
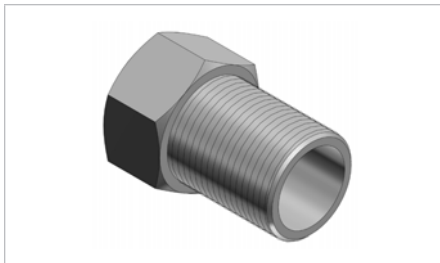

For reducing the threaded opening in conduit bodies or any female threaded fitting. Smooth, built-in bushing completely covers rough ends of conduit. Iron or steel construction. Steel from 600-TB thru 606-TB, also 614 & 615.

Threaded Reducers



Cat. No.	Stl. or M.I.	Alum.	Size (in.)	Dimensions (in.)	
				A	
600-TB		600AL-TB	1/2 to 3/8	5/8	
601-TB		601AL-TB	3/4 to 1/2	19/32	
602-TB		602AL-TB	1 to 1/2	19/32	
603-TB		603AL-TB	1 to 3/4	19/32	
604-TB		604AL-TB	1-1/4 to 1/2	19/32	
605-TB		605AL	1-1/4 to 3/4	19/32	
606-TB		606AL	1-1/4 to 1	11/16	
607		607AL	1-1/2 to 1/2	15/16	
608		608AL	1-1/2 to 3/4	15/16	
609		609AL	1-1/2 to 1	1-3/32	
610		610AL	1-1/2 to 1-1/4	27/32	
611-TB		611AL	2 to 1/2	23/32	
612		612AL	2 to 3/4	1-1/16	
613		613AL	2 to 1	1-1/16	
614-TB		614AL	2 to 1-1/4	1-1/16	
615-TB		615AL	2 to 1-1/2	27/32	

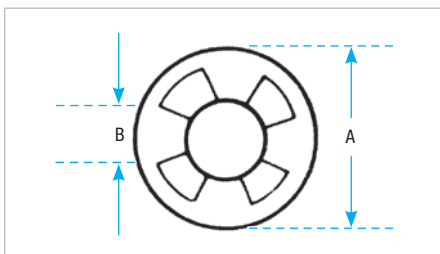
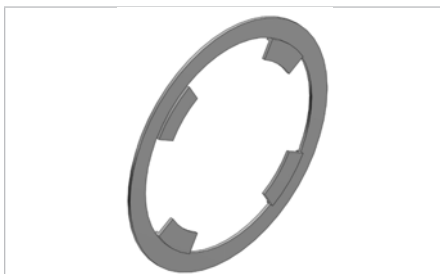

Washers reduce knockout hole in outlet box. Newly designed of galvanized steel. These washers, used in pairs, interlock and form a rib which centers the washers and conduit in the knockout.

Reducing Washers



Cat. No.	Size (in.)	Dimensions (in.)	
		A	B
3700	3/4 to 3/8	1-3/8	45/64
3701	3/4 to 1/2		7/8
3702	1 to 3/8	1-5/8	45/64
3703	1 to 1/2		7/8
3704	1 to 3/4	1-3/32	
3705-TB	1-1/4 to 3/8	2	45/64
3706	1-1/4 to 1/2		7/8
3707	1-1/4 to 3/4		1-3/32
3708	1-1/4 to 1		1-23/64
3709	1-1/2 to 3/8	2-1/4	45/64
3710	1-1/2 to 1/2		7/8
3711	1-1/2 to 3/4		1-3/32
3712	1-1/2 to 1		1-23/64
3713	1-1/2 to 1-1/4	1-23/32	
3714	2 to 1/2	2-3/4	7/8
3715-TB	2 to 3/4		1-3/32
3716	2 to 1		1-23/64
3717	2 to 1-1/4		1-23/32
3718	2 to 1-1/2		1-31/32

Rigid and Intermediate Metal Conduit Fittings

Conduit Straps for Threaded Rigid Metal Conduit and Intermediate Metal Conduit



1275 Series
1276AL Series

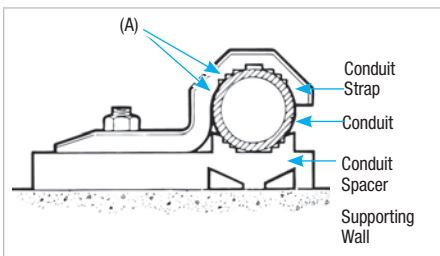

Application

- To support and securely fasten rigid metal conduit and intermediate metal to the supporting surface

Features

- Rugged malleable iron/copper-free aluminum construction—snugly fits on the conduit
- Designed to prevent accumulation of moisture and start of corrosion on vertical run of conduit (A)

Standard Material

1275 Series
Malleable Iron

1976AL Series
All copper-free aluminum

Standard Finish

1275 Series
Hot Dipped Galvanized

1276AL Series
As Cast

Range

- **1275 Series**
3/8 in. through 6 in. conduit
- **1276AL Serie**
1/2 in. through 6 in. conduit

Conformity

CSA C22.2 No. 18.3

ANSI C80.4

NFPA 70-2008 (ANSI)

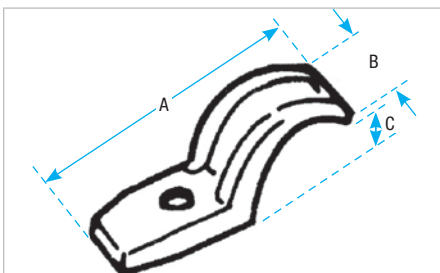
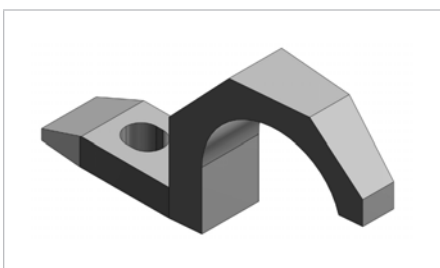

Designed to fit each size of conduit snugly. High reinforcing ribs on each side increase strength, reduce weight. Hot-dipped galvanized finish.

Pipe Straps – Malleable Iron or Aluminum



Cat. No.	Size (in.)		Dimensions (in.)			Screw Size (in.)
	Mal. Iron	Alum.	A	B	C	
1275†	1275AL	3/8	1-15/16	19/32	1/4	1/4
1276†	1276AL†	1/2	2-11/32	23/32	1/2	
1277†	1277AL†	3/4	2-11/16	21/32	5/8	
1278†	1278AL†	1	3-3/32	11/16	13/16	
1279†	1279AL†	1-1/4	4-1/8	13/16	29/32	5/16
1280†	1280AL	1-1/2	4-1/2	15/16	1-17/32	3/8
1281	1281AL	2	5-3/16	1-1/8	1-1/4	7/16
1282*	1282AL	2-1/2	5-15/16	1-1/2	1-3/4	1/2
1283*	1283AL	3	6-11/16	1-5/8	2-3/16	
1284	1284AL	3-1/2	7-19/32	1-3/4	2-3/4	5/8
1285*	1285AL	4	8-5/16	1-7/8	2-13/16	
1286**	1286AL**	4-1/2	9-3/16	1-15/16	2-15/16	
1287	1287AL	5	9-15/16	2	3-1/4	
1288	1288AL	6	11-1/2	2-7/16	4-1/8	

* May be used with EMT of same size

† Not snap on type

UL not applicable

** Not CSA Certified

Rigid and Intermediate Metal Conduit Fittings

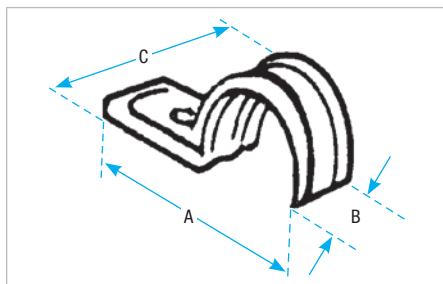
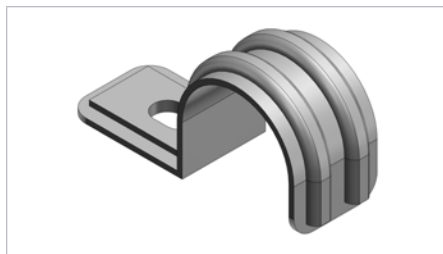

Elongated bolt hole makes alignment easy, even when holes in mounting surface are off center. Snap on features. Steel.

Zinc plated.

Pipe Straps – Steel



Cat. No.	Conduit Size (in.)	Dimensions (in.)			Screw Size (in.)
		A	B	C	
1210C†	3/8	1-15/32	3/4	11/16	1/4
1211C	1/2	2	3/4	15/16	
1212C	3/4	2-5/16	3/4	1"	
1213C	1	3-13/16	3/4	1-17/64	
1214TB*	1-1/4	2-31/32	1-9/16	1-9/16	3/8
1215TB*	1-1/2	3-23/32	1-13/16	1-13/16	
1216TB*	2	4-7/16	2-5/16	2-5/16	

† Not snap on type
UL not applicable
* Not CSA Certified

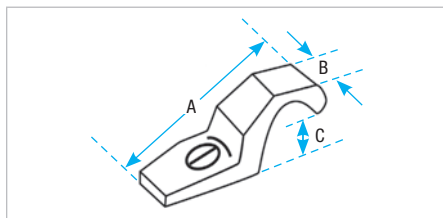
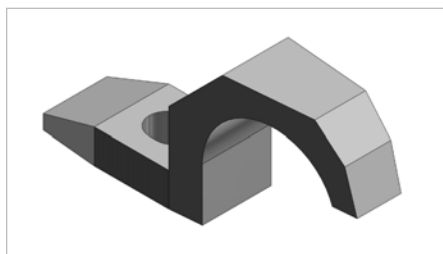

Malleable iron. Designed to fit each size of conduit snugly. High reinforcing ribs on each side increase strength, reduce weight.

Corrosion Resistant PVC Coated Rigid Conduit Straps



Cat. No.	Size (in.)	Bolt Size (in.)	Dimensions (in.)		
			A	B	C
1275CR	3/8	1/4	2	21/32	1/4
1276CR	1/2		2-13/32	25/32	1/2
1277CR	3/4		2-3/4	23/32	5/8
1278CR	1		3-5/32	3/4	13/16
1279CR	1-1/4	3/8	4-5/32	25/32	7/8
1280CR	1-1/2		4-9/16	1	1-7/32
1281CR	2		5-1/4	1-3/16	1-1/4

UL not applicable

Rigid and Intermediate Metal Conduit Fittings

Conduit Spacers for Rigid Metal Conduit, Intermediate Metal Conduit and Electrical Metal Tubing



1350 Series
1350AL Series

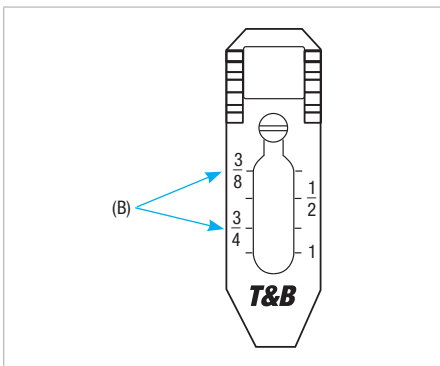
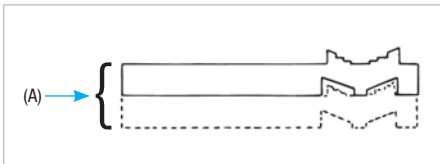
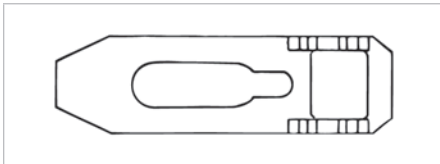

Application

- Provides mounting surface for conduit where installation requires air space between conduit and supporting surface

Features

- Prevents conduit rusting from wall condensation
- Spacers can be stacked one atop the other facilitating installation and eliminating expensive conduit off setting (A)
- Designed to cover wide range; marked with accurate size marking for proper positioning (B)

Standard Material

1350 Series

Malleable Iron

1350AL Series

Copper-free aluminum

Standard Finish

1350 Series

Hot Dipped Galvanized

1350AL Series

As Cast

Range

1/2 in. through 6 in. conduit

Conformity

CSA C22.2 No. 18.3

ANSI C80.4

NFPA 70-2008 (ANSI)

Rigid and Intermediate Metal Conduit Fittings

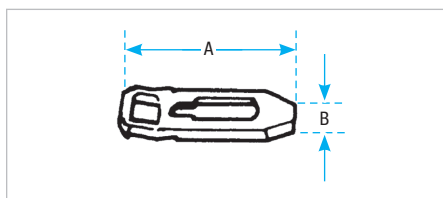
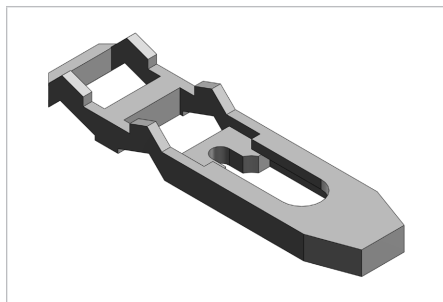

Used with T&B conduit straps to permit space between conduit and mounting surface. Eliminates need for costly offset-bending conduit and possible corrosive moisture traps when conduit is mounted directly to a surface. Hot-dipped galvanized finish, pre-mountable and stackable to eliminate offsetting.

Pipe Spacers



Cat. No.		Size (in.)	Screw Size	Dimensions (in.)	
Mal. Iron	Alum.			A	B
1350	1350AL	3/8, 1/2, 3/4, 1	#7	3	7/8
1351	1351AL	1-1/4-1-1/2-2	#12	5	1-3/16
1352	1352AL	2-1/2-3	#12	9-9/16	1-3/4
1353	1353AL	3-1/2-4	#14	7-9/16	2

Conforms to CEC Rule 12-012 (5)
UL not applicable

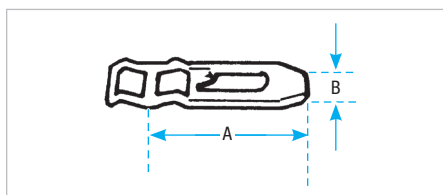
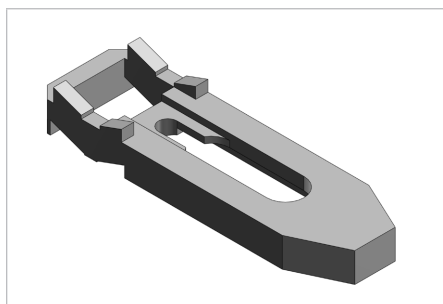

Corrosion resistant PVC coated malleable iron. Pre-mountable, stackable to eliminate offsetting. Spacers can be stacked for offsets on wall or into outlet box.

Prevents conduit rusting from wall condensation. Eliminates offsetting of conduit.

Pipe Spacers – PVC Coated



Cat. No.	Conduit Size (in.)	Screw Size	Dimensions (in.)	
			A	B
1350CR	1/2-3/4-1	#7	3	7/8
1351CR	1-1/4-1-1/2-2	#12	5	3/8
1352CR	2-1/2-3	#12	6-9/16	1-3/4
1353CR	3-1/2-4	#14	7-9/16	2

Conforms to CEC Rule 12-012 (5)
UL not applicable

Rigid and Intermediate Metal Conduit Fittings

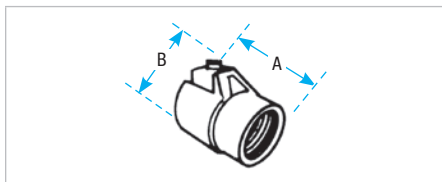
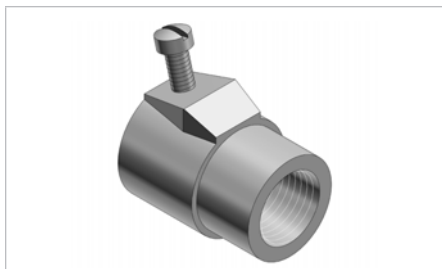

A one-piece fitting that couples armoured cable or flexible conduit to threaded rigid conduit. Tite-Bite® wedge holds conduit securely with a double grip. With a Chase® nipple, this fitting will connect flexible conduit to outlet boxes, allowing more wiring space in the box than the usual fitting. Malleable iron.

Tite-Bite® Combination Couplings Armoured Cable for Threaded Rigid



Cat. No.	Size (in.)	Dimensions (in.)	
		A	B
440	1/2	1-5/8	1-27/32
441	3/4	1-3/4	2-1/8
442	1	2	2-17/32

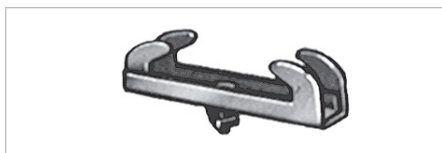

Includes bolts Steel

Beam Clamps Adjustable



Cat. No.	Description
700TB	Fits Flange 2-3/4 in. - 7-3/8 in.
703*	Special Bolt and 3 Nuts

* Not CSA Certified



These supports will fit any flange, tapered or straight up to 5/8 in. thick. The broad hook holds the conduit at any desired angle. Holds standard rigid conduit, EMT, or I.M.C. Malleable iron.

Conduit Supports



Cat. No.	Size (in.)
690TB	1/2
691TB	3/4
692TB	1
693TB	1-1/4

Rigid and Intermediate Metal Conduit Fittings

Methods of Bonding and Grounding

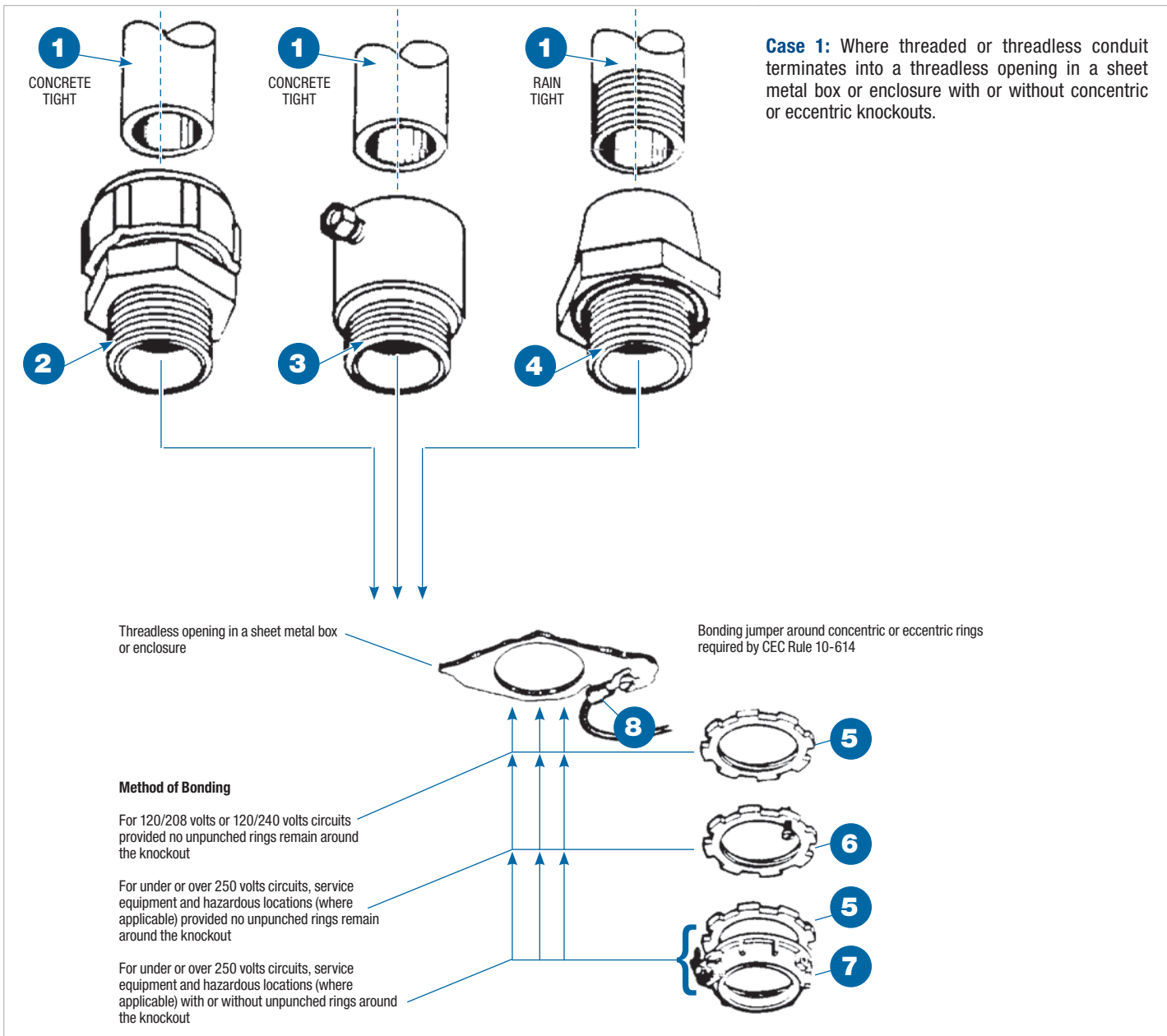

- (1) Threaded or threadless rigid metal conduit or intermediate metal conduit
- (2) T&B Series 8123 or 8124 Threadless Fittings

- (3) T&B Series 8125 Set Screw Fitting
- (4) T&B Series 370 or H050-TB Sealing Hub (Bullet® Hubs)
- (5) T&B Series 140 Locknuts

- (6) T&B Series 106 Bonding Locknut
- (7) T&B Series 3870 Bonding & Grounding Bushing
- (8) T&B Sta-Kon® or Colour-Keyed® lug

Rigid and Intermediate Metal Conduit Fittings

Methods of Bonding and Grounding (cont'd)

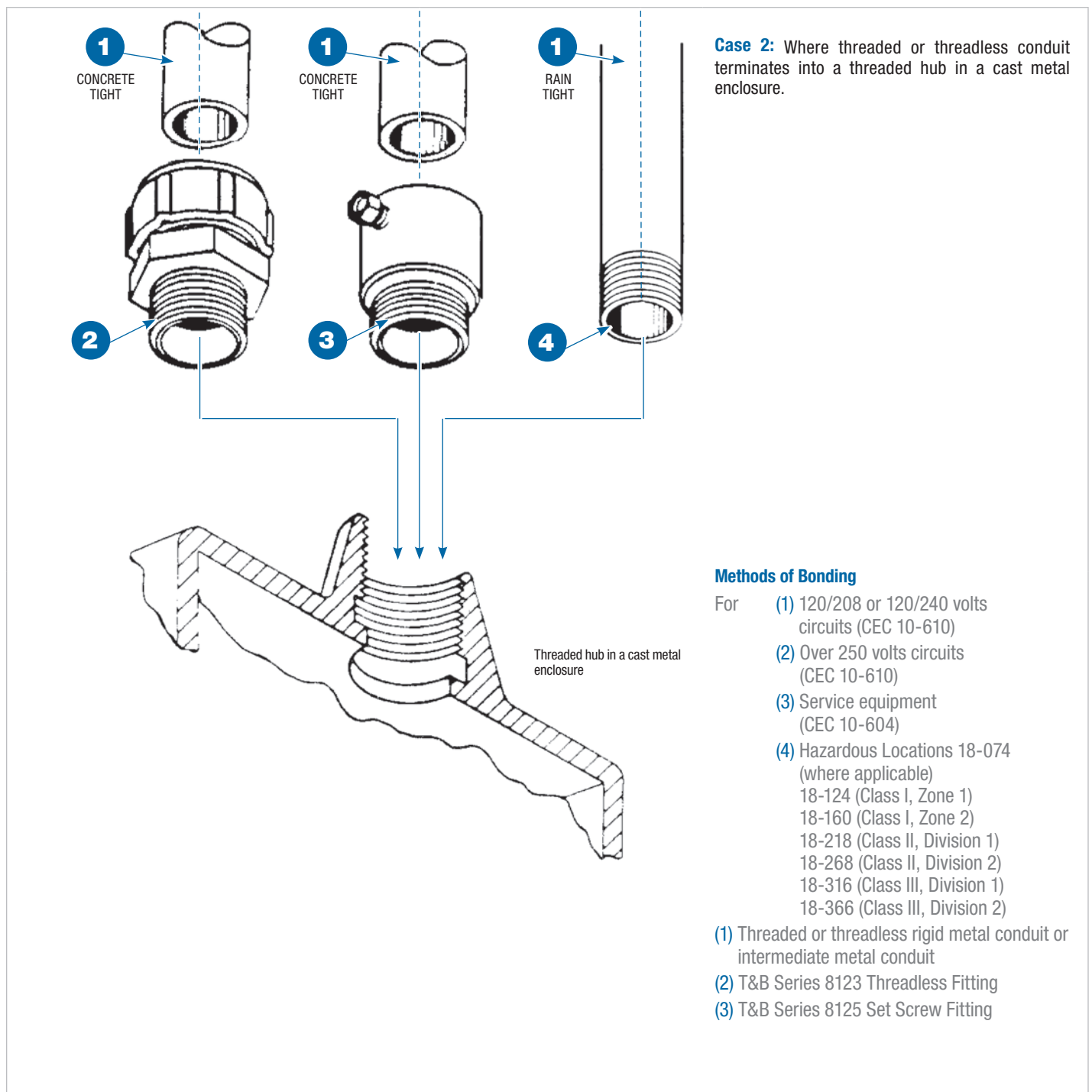

Rigid and Intermediate Metal Conduit Fittings

Methods of Bonding and Grounding (cont'd)

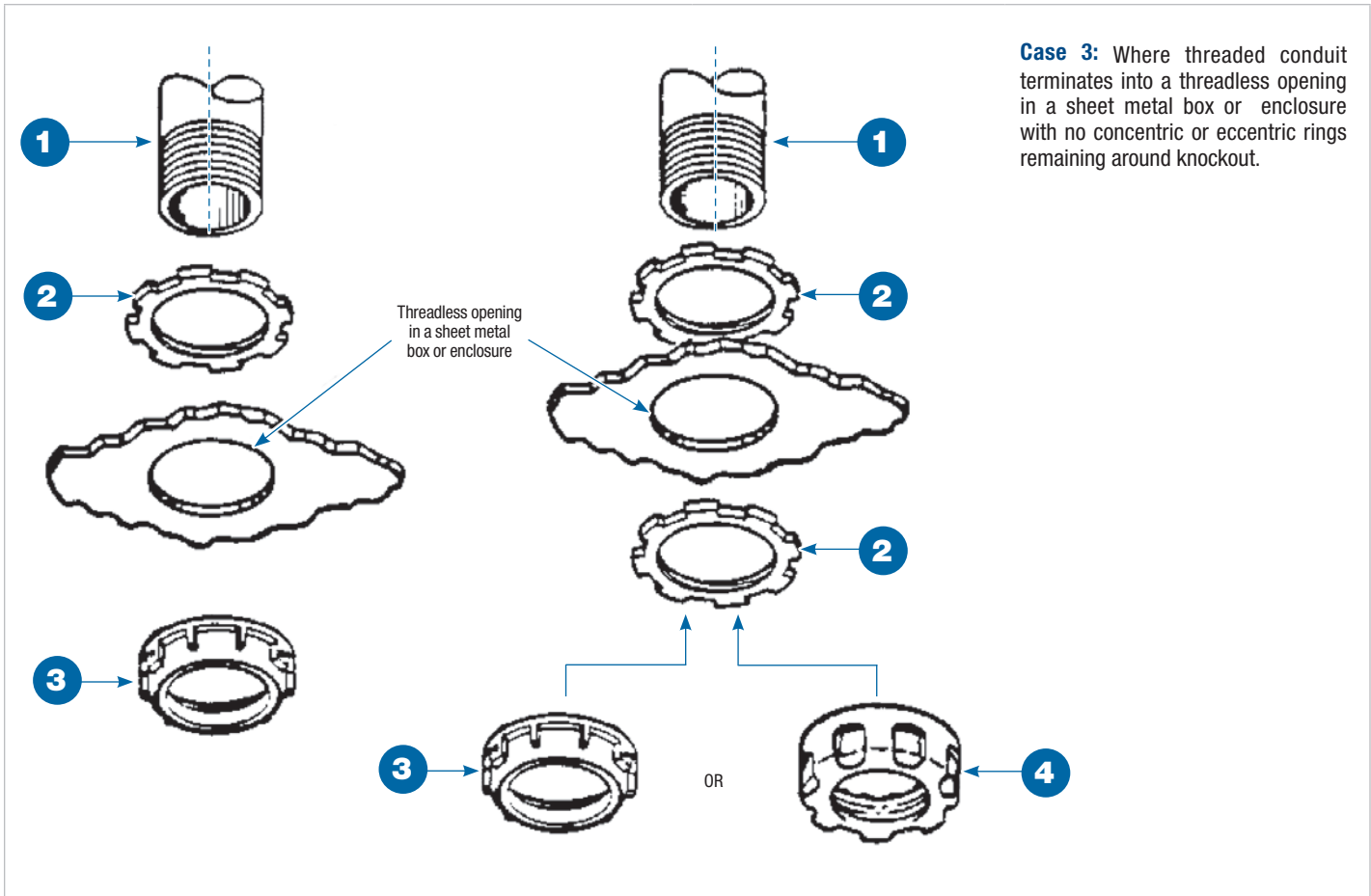

Case 3: Where threaded conduit terminates into a threadless opening in a sheet metal box or enclosure with no concentric or eccentric rings remaining around knockout.

Method of bonding for 120/208 volt or 120/240 volts circuits (other than service equipment).

Method of bonding for over 250 volts circuits e.g. 600/347 volt systems and those operating over 600 volts (other than service equipment).

Note: Any of the bonding methods described for service equipment may also be used

Rigid and Intermediate Metal Conduit Fittings

Methods of Bonding and Grounding (cont'd)

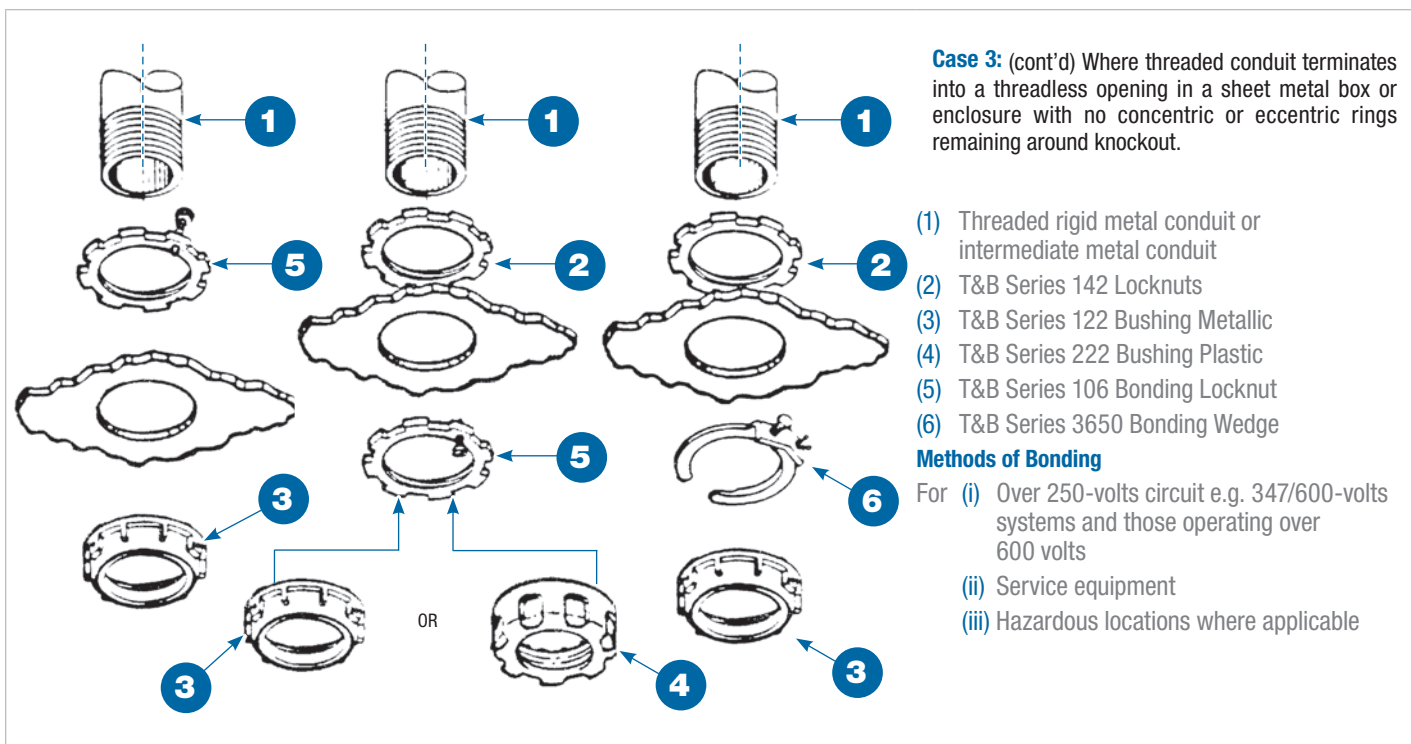

Rigid and Intermediate Metal Conduit Fittings

Methods of Bonding and Grounding (cont'd)

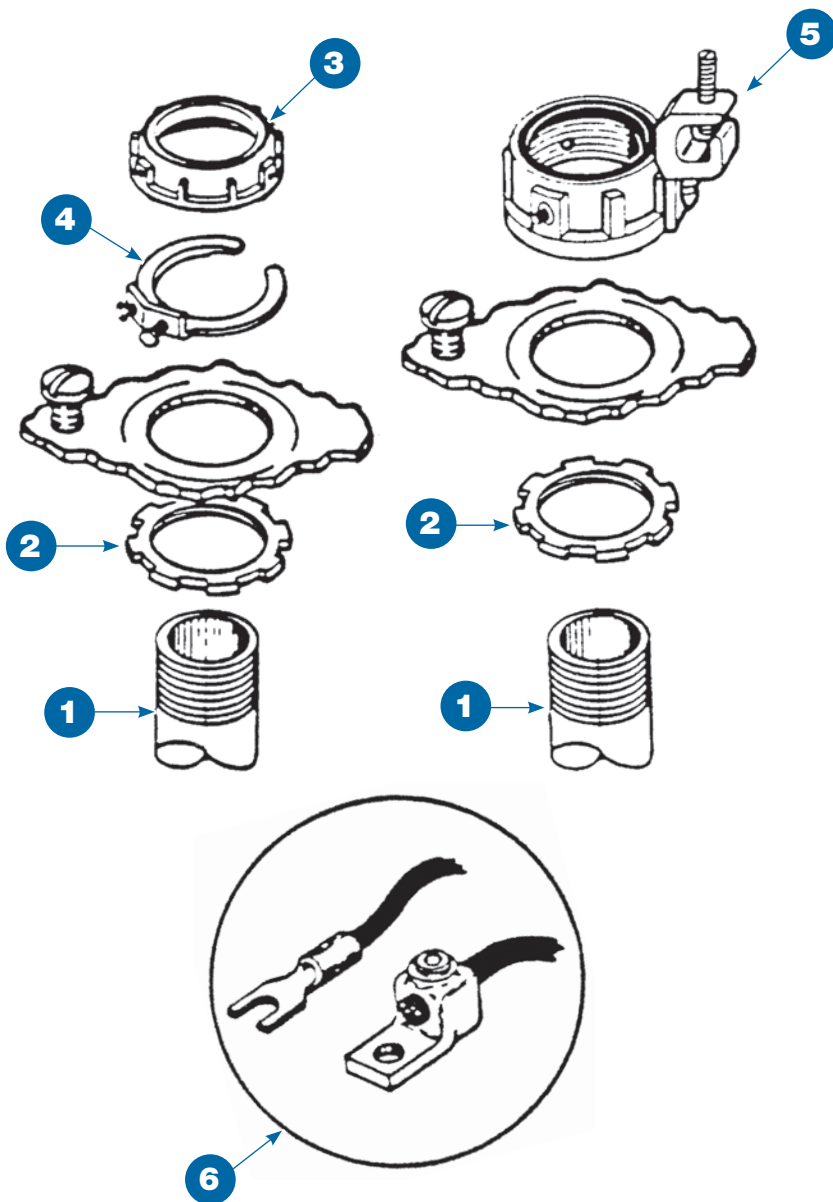

Case 4: Where threaded conduit terminates into a threadless opening in a sheet metal box or enclosure with concentric or eccentric rings remaining around knockout.

Methods of bonding for under or over 250-volts, for service equipment and for hazardous locations where applicable.

Note: Bonding jumper required by CEC Rule 10-614

- (1) Threaded rigid metal conduit or intermediate metal conduit
- (2) T&B Series 142 Locknuts
- (3) T&B Series 122 Bushing, Metallic
- (4) T&B Series 3650 Bonding Wedge
- (5) T&B Series 3870 Bonding and Grounding Bushing
- (6) T&B Typical Mechanical or Pressure Type Fitting

Note: For raintight applications, a sealing ring, T&B Series 5302, may be used between outside of box or enclosure and the outside locknut.

Rigid and Intermediate Metal Conduit Fittings

Methods of Bonding and Grounding (cont'd)

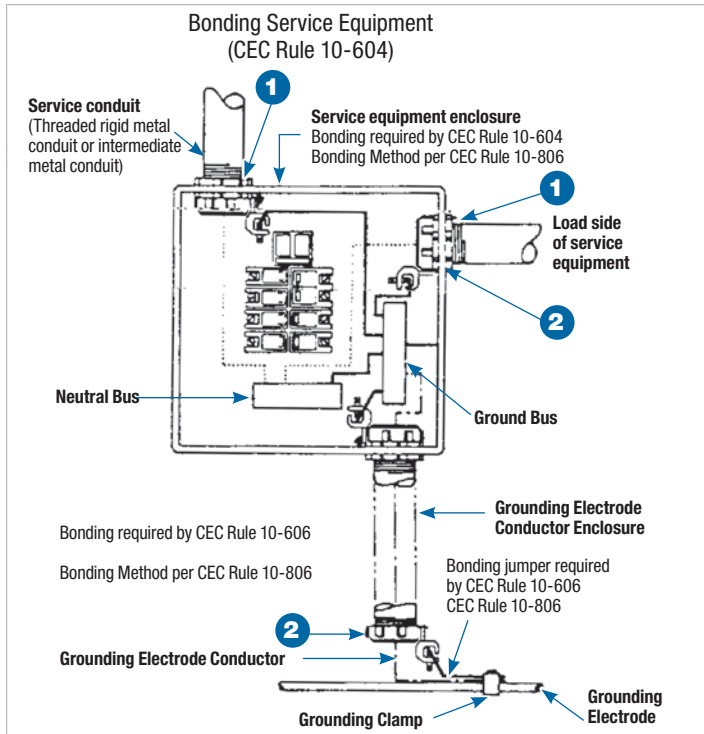

Install Bonding Jumper to Assure Electrical Continuity Between Isolated Sections of Raceways (CEC Rule 10-614)

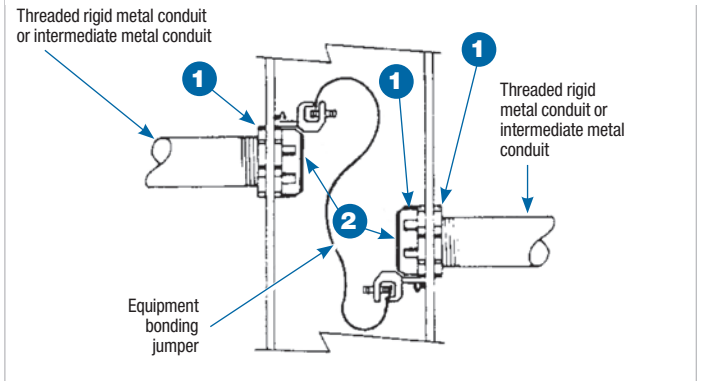

- (i) Installing bonding jumper around unpunched concentric or eccentric knockouts in sheet metal box or enclosure [CEC Rule 10-806]
- (ii) Installing bonding jumper in hazardous locations where 'locknut bushing' or 'double locknut' type of contact is unacceptable method for bonding purposes [CEC Rule 18-074]

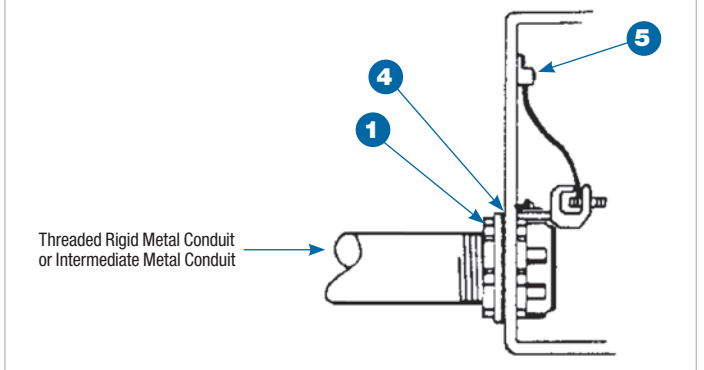
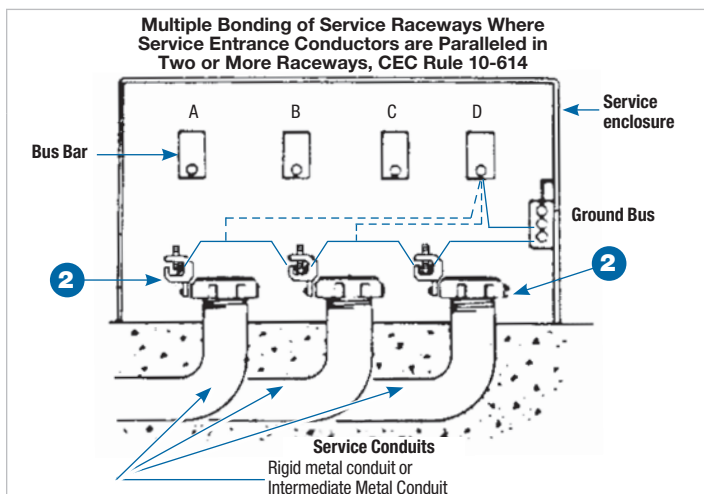

- 1 T&B Series 142 Locknut
- 2 T&B Series 3870 Bonding and Grounding Bushing (Threaded)
- 3 T&B Series 5262 Sealing "O" Ring
- 4 T&B Typical Bolted or Pressure Lug

Suggested Specifications

Insulated grounding and bonding bushing (Series 3870)

Where code requires bonding and grounding of single or multiple metal conduits, or positive bonding and grounding of metal conduit to the box, enclosure or auxiliary gutter, the end of the conduit shall be equipped with an insulated metallic grounding and bonding bushing such as Series 3870 manufactured by Thomas & Betts.

Grounding and bonding bushings used shall be approved for the purpose and

- (1) Shall be of malleable iron/steel/aluminum construction adequately protected against corrosion
- (2) Bushing insulator shall be listed or certified for 150°C/302°F application with a flammability rating of 94V-0. Insulator must be positively locked in place

Rigid and Intermediate Metal Conduit Fittings

Methods of Bonding and Grounding (cont'd)

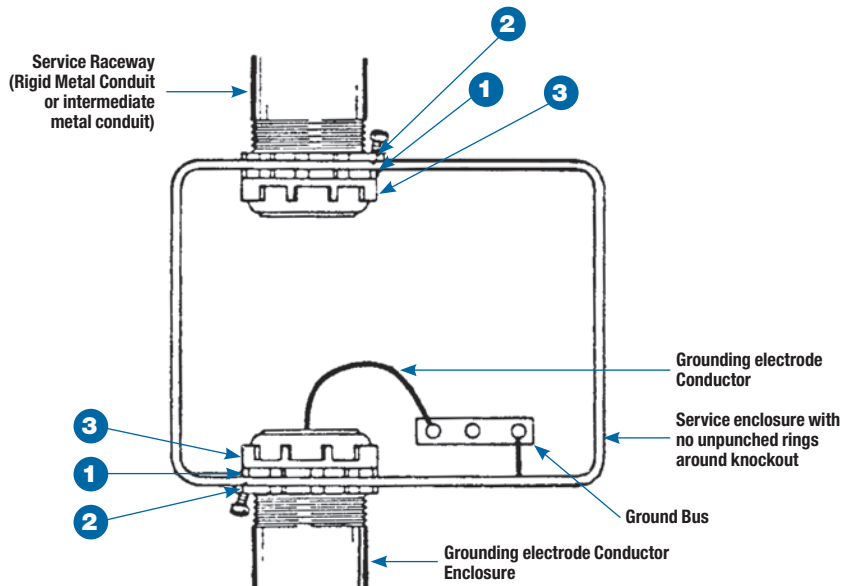

- (1) T&B Series 142 Locknut
- (2) T&B Series 106 Bonding Locknuts
- (3) T&B Series 122 Bushing

Suitable for Bonding Raceway, EMT or Terminating Fitting to a sheet metal box or enclosure where

- (a) No unpunched concentric or eccentric rings remain around the knockout
- (b) Ordinary locknut is unacceptable for bonding purposes such as
 - (i) Service Equipment Enclosures CEC Rule 10-614
 - (ii) Bonding for circuits over 250 volts (where required) CEC Rule 10-614
 - (iii) Bonding in Hazardous Locations regardless of the voltage of the system CEC Rule 18-074

Suggested Specifications

Bonding Type Locknut (Series 106)

Where drawings indicate installation of a bonding type locknut to effectively bond a terminating fitting or metal conduit to a cabinet, box, enclosure or an auxiliary gutter, the locknuts installed shall be of hardened steel/malleable iron construction, electro-zinc plated, such as Series 106 manufactured by Thomas & Betts.

Rigid and Intermediate Metal Conduit Fittings

Methods of Bonding and Grounding (cont'd)

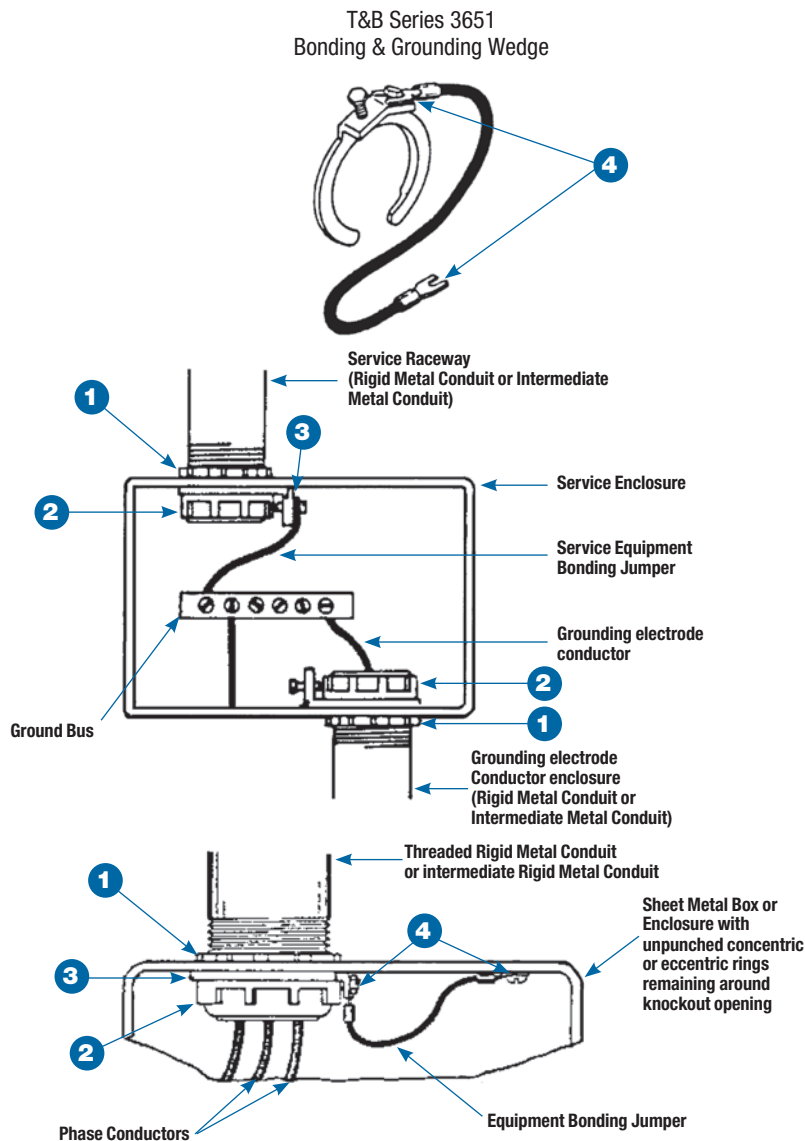

- (1) T&B Series 142 Locknut
- (2) T&B Series 122 Metallic Bushing
- (3) T&B Series 3651 Bonding & Grounding Wedge
- (4) T&B Pressure (crimp type) Terminal Lug

Acceptable Method for Bonding Following

- (i) Service Equipment
CEC Rule 10-614
- (ii) Bonding for Circuits over 250 volts
CEC Rule 10-614
- (iii) Bonding in Hazardous Locations
CEC Rule 18-074

When installed with a bonding jumper, acceptable method of bonding where unpunched rings remain around concentric or eccentric knockouts in sheet metal boxes or enclosures. [CEC Rule 10-614].

Suggested Specifications

Bonding and Grounding Wedge (Series 3650)

Bonding and Grounding Wedges installed to effectively bond terminating fitting or metal conduit to a cabinet, box, enclosure or an auxiliary gutter or to install bonding jumper around concentric or eccentric knockouts shall be of the type as manufactured by Thomas & Betts — Series 3650.

Bonding and Grounding Wedge shall be of rugged bronze/tin-plated or steel/electro-zinc plated.