

SMC-50 Soft Starters

Bulletin 150



Important User Information

Read this document and the documents listed in the additional resources section about installation, configuration, and operation of this equipment before you install, configure, operate, or maintain this product. Users are required to familiarize themselves with installation and wiring instructions in addition to requirements of all applicable codes, laws, and standards.

Activities including installation, adjustments, putting into service, use, assembly, disassembly, and maintenance are required to be carried out by suitably trained personnel in accordance with applicable code of practice.

If this equipment is used in a manner not specified by the manufacturer, the protection provided by the equipment may be impaired.

In no event will Rockwell Automation, Inc. be responsible or liable for indirect or consequential damages resulting from the use or application of this equipment.

The examples and diagrams in this manual are included solely for illustrative purposes. Because of the many variables and requirements associated with any particular installation, Rockwell Automation, Inc. cannot assume responsibility or liability for actual use based on the examples and diagrams.

No patent liability is assumed by Rockwell Automation, Inc. with respect to use of information, circuits, equipment, or software described in this manual.

Reproduction of the contents of this manual, in whole or in part, without written permission of Rockwell Automation, Inc., is prohibited

Throughout this manual, when necessary, we use notes to make you aware of safety considerations.



WARNING: Identifies information about practices or circumstances that can cause an explosion in a hazardous environment, which may lead to personal injury or death, property damage, or economic loss.



ATTENTION: Identifies information about practices or circumstances that can lead to personal injury or death, property damage, or economic loss. Attentions help you identify a hazard, avoid a hazard, and recognize the consequence.

IMPORTANT Identifies information that is critical for successful application and understanding of the product.

Labels may also be on or inside the equipment to provide specific precautions.



SHOCK HAZARD: Labels may be on or inside the equipment, for example, a drive or motor, to alert people that dangerous voltage may be present.



BURN HAZARD: Labels may be on or inside the equipment, for example, a drive or motor, to alert people that surfaces may reach dangerous temperatures.



ARC FLASH HAZARD: Labels may be on or inside the equipment, for example, a motor control center, to alert people to potential Arc Flash. Arc Flash will cause severe injury or death. Wear proper Personal Protective Equipment (PPE). Follow ALL Regulatory requirements for safe work practices and for Personal Protective Equipment (PPE).

Product Overview

Preface11
 About This Publication..... 11
 Terminology..... 11
 General Precautions 11
 Summary of Changes 14
 Additional Resources 14

Chapter 1
 Introduction..... 15
 Features 16
 Starting Modes..... 16
 Soft Start 16
 Linear Speed Acceleration..... 17
 Torque Control Start..... 18
 Current Limit Start..... 18
 Selectable Kickstart 19
 Pump Control Mode 19
 Dual Ramp Start 20
 Full Voltage Start..... 20
 Preset Slow Speed 21
 Integral Motor Winding Heater (starting feature)..... 21
 Stopping Modes..... 21
 Coast..... 21
 Soft Stop..... 22
 Linear Speed Deceleration..... 22
 Pump Stop..... 23
 Braking Control Modes..... 23
 SMB—Smart Motor Braking..... 24
 Slow Speed with Braking 24
 Accu-Stop 25
 External Braking Control 25
 Internal Bypass Modes..... 25
 Solid-state Running Modes 26
 SCR Control - Normal Run Operation..... 26
 SCR Control – Energy Saver Run Operation 26
 External Bypass – Optional Run Operation..... 26
 Emergency Run 27
 Resistor Loads..... 27
 Motor and Starter Protection Features 27
 Starter Protection Features 28
 Metering System 29
 Communications..... 30
 Motor Protection Features 31
 Controller Parameter Configuration..... 32

Configuration by Keypad and LCD Display (Human Interface Module Cat. No. 20-HIM-A6) 33
 Configuration by PC Programmable Software 33
 Parameter Configuration Option Module (Cat. No.150-SM6) 33
 Control Inputs and Outputs 34
 Standard Inputs 34
 Optional Inputs 35
 Standard and Optional Outputs 35
 Optional PTC, Ground Fault, and Current Transformer Interface Capability 36

Chapter 2

Wiring

Wiring Terminal Locations 37
 Power Wiring 37
 Grounding Provision 40
 Protective Modules 41
 Electromagnetic Compatibility (EMC) 42
 Enclosure 42
 Wiring 42
 Additional Requirements 42
 Power Wiring with External Bypass 44
 Line-connected Motors 44
 Delta-connected Motors 47
 Control Wiring 48
 Standard Control Terminal Block 48
 Control Wiring Specifications 48
 Standard Controller Wiring Diagrams 50
 Soft Stop, Pump Control, and Smart Motor Braking (SMB) 67
 Slow Speed with Braking 68
 Preset Slow Speed 70
 Fan Wiring 73
 Integrated Bypass Units 73
 Solid-state Units 73
 Upgraded Units 73

Chapter 3

Operating Modes

Operation 75
 Motor Configuration 75
 Motor Tuning 75
 Resistive Loads 76
 Three-phase Balanced Loads 77
 Starting Modes 79
 Overview 79
 Linear Speed (Linear Acceleration) 79
 Soft Start 80
 Selectable Kickstart 81

Current Limit Start	82
Full Voltage Start	83
Torque Control Start	84
Pump Control Start and Stop	85
Additional Start Features—Functions	86
Dual Ramp Start	86
Start Timer (Start Delay)	87
Timed Start	88
Backspin Timer	88
Motor Winding Heater Function	88
Stopping Modes	89
Overview	89
Coast-to-Stop	89
Soft Stop	90
Linear Speed (Linear Deceleration)	90
Smart Motor Braking (SMB)	91
Preset Slow Speed and Slow Speed with Braking	92
Accu-Stop™	93
External Braking Control	95
Running Modes	95
Internal Bypass Modes	95
Solid-state (SCR) Control Mode	95
External Bypass Control Mode	95
Energy Saver Mode	97
Emergency RUN	98
Sequence of Operation	98

Chapter 4

Special Application Considerations

Introduction	107
Design Philosophy	107
Line Voltage Conditions	107
Current and Thermal Ratings	107
Mechanical Shock and Vibration	107
Noise and Radio Frequency (RF) Immunity	107
Altitude	107
Pollution	108
Atmospheric Protection	108
Setup	108
Motor Overload Protection	108
Multiple Motors	109
Special Motors	109
SMC-50 Motor Winding Heater	111
Internal	111
External	111
Stall Protection and Jam Detection	112
Communication	112
Power Monitoring	113

Power Factor Correction Capacitors 114
 Altitude De-rating 115
 Isolation Contactor 116
 Application Uses for SMC-50 Controller Power Structures..... 117
 SMC-50 Solid-state Controller 117
 SMC-50 Controller with Integrated Bypass..... 118
 SMC-50 Controller with External Bypass 119

Chapter 5

Protection and Diagnostic Functions

Overview 121
 20-HIM-A6, 20-HIM-C6S, and Configuration Software 122
 Enabling Starter and Motor Faults and Alarms 122
 Enabling Option Module Functional Faults and Alarm 125
 Protection and Diagnostics 126
 Overload—Fault and Alarm 126
 Underload—Fault and Alarm 129
 Line Power Undervoltage Protection 130
 Line Power Overvoltage Protection—Fault and Alarm 131
 Current Imbalance Protection—Fault and Alarm 131
 Voltage Unbalance Protection—Fault and Alarm 132
 Phase Reversal Protection 133
 High and Low Line Power Frequency Protection—
 Fault and Alarm 133
 Stall Protection—Fault and Alarm 134
 Jam Detection—Fault and Alarm 136
 Real Power Protection (MWatts) 137
 Motor Over Power Real—Fault and Alarm 137
 Motor Under Power Real—Fault and Alarm 138
 Reactive Power Protection (MVAR) 138
 Motor Over Power Reactive Positive (Motor Consumed)—
 Fault and Alarm 138
 Motor Under Power Reactive Positive (Motor Consumed)—
 Fault and Alarm 139
 Motor Over Power Reactive Negative (Motor Generated)—
 Fault and Alarm 140
 Motor Under Power Reactive Negative (Motor Generated)—
 Fault and Alarm 140
 Apparent Power Protection (MVA) 141
 Motor Over Power Apparent—Fault and Alarm 141
 Motor Under Power Apparent—Fault and Alarm 142
 Power Factor Protection 142
 Motor Power Factor (PF)—Fault and Alarm 142
 Excessive Starts/Hour Protection 143
 Motor Starts/Hour—Fault and Alarm 143
 Preventive Maintenance Protection 144
 Preventive Maintenance (PM) Hours Protection—
 Fault and Alarm 144

PM Starts Protection—Fault and Alarm.....	144
Line Loss Protection.....	145
Silicon-Controlled Rectifier (SCR) Protection.....	145
Shorted SCR Fault—Phase A, B, or C.....	145
SCR Overtemperature—Fault.....	146
Open SCR Gate Fault and Alarm—Phase A, B, or C.....	146
Open Bypass—Phase A, B, or C.....	146
Power Quality.....	147
Power Quality Fault and Alarm—Phase A, B, or C.....	147
Total Harmonic Distortion (THD) Fault and Alarm.....	147
Power Pole Overtemperature—Fault.....	148
Open Load—Fault and Alarm.....	148
Current Transformers (CT) Loss—Fault.....	148
Locked Rotor—Fault and Alarm.....	149
Expansion Module Functions.....	149
Expansion Device Removed Fault.....	149
Expansion Device Fault.....	150
Expansion Module Incompatible Fault.....	150
Real Time Clock (RTC).....	150
Battery Low.....	150
Configuration Functions.....	151
Configuration Change—Fault and Alarm.....	151
I/O Configuration—Fault.....	151
Buffers and Storage Functions.....	151
Non-volatile Storage (NVS) Fault.....	151
Fault Buffer and Fault Storage Parameters.....	151
Alarm/Event Buffer and Alarm/Event Storage Parameters.....	152
Auto Restart from Fault Function.....	153

Chapter 6

Programming

Overview.....	155
Human Interface Module (HIM) (Cat. No. 20-HIM-A6 or 20-HIM-C6S).....	155
Password Modification Using the HIM.....	157
Parameter Access Level Modification Using the HIM.....	158
Parameter Management.....	159
RAM (Random Access Memory).....	160
ROM (Read-only Memory)—Set Defaults.....	160
EEPROM.....	161
Parameter Configuration.....	161
Using the START UP Configuration Tool (20-HIM-A6 or 20-HIM-C6S).....	161
Parameter Search and Configuration.....	164
Parameter Search and Configuration by Parameter Number..	165
Parameter Search and Configuration by File-Group Structure	166
Parameter Configuration - Using the Setup File Group.....	168
Overview.....	168

Soft Start and Stop	169
Current Limit Start with Simple Stop Mode	170
Linear Acceleration (Linear Speed) Start with Stop	171
Torque Start with Stop	173
Pump Start with Stop	174
Full Voltage Start with Stop	175
Dual Ramp Start with Stop	176
Start Options	177
Stop Options	178
Slow Speed with Braking	178
Accu-Stop	179
Motor Protection	179
Parameter File-Group Structure	181
SMC-50 Controller Option Module Configuration	189
Basic Configuration using the HIM	189
150-SM4 Digital I/O Option Module	190
150-SM6 Parameter Configuration Option Module	193
150-SM2 PTC, Ground Fault, and External Current Transformer Module	194
Parameter Configuration Module	196
Using the Parameter Configuration Module (150-SM6)	196

iChapter 7

Metering

Overview	203
Viewing Metering Data	203
Resetting Metering Parameters	204
Metering Parameters	204
Current	204
Voltage	205
Torque	205
Power	205
Power Factor	206
Energy Savings	207
Elapsed Time	207
Running Time	208
Motor Speed	208
Actual Start Time	208
Peak Start Current	208
Total Starts	209
Total Harmonic Distortion (THD)	209
Line Frequency	210
Current Imbalance	210
Voltage Unbalance	210

	Chapter 8	
Optional HIM Operation	Overview	211
	HIM Control Buttons	211
	HIM Control Screen	212
	CopyCat Function of the 20-HIM-A6	214
	Chapter 9	
Communications	Overview	215
	Communication Ports	215
	HIM Keypad and Displays	216
	Connecting the HIM to the Controller	216
	Control Enable	217
	Logic Mask Enable/Disable using a HIM	217
	Loss of Communication with DPI Device	219
	Default Input/Output Communication Configuration	219
	Variable Input/Output Configuration	220
	SMC-50 Controller—Bit Identification	220
	Reference/Feedback	221
	Parameter Information	221
	Scale Factors for PLC Communication	221
	Display Text Unit Equivalents	222
	Configuring DataLink™	222
	Criteria for Using DataLink	222
	Updating Firmware	223
	Chapter 10	
Diagnostics	Overview	225
	Protection Programming	225
	Diagnostic LEDs	225
	Fault Display (20-HIM-A6)	227
	Clear Fault	228
	Fault and Alarm Buffer - Parameter List	228
	Accessing the Fault and Alarm Parameters	228
	Accessing the Fault and Alarm Buffers	230
	Fault Codes	232
	Auxiliary Relay Output Fault or Alarm Indication	236
	Chapter 11	
Troubleshooting	Introduction	237
	Power Module Check	244
	Shorted SCR Test	244
	Appendix A	
Parameter Information	SMC-50 Controller Information	245
	150-SM6 PCM Information	269

	150-SM4 Digital I/O Module Information.....	269
	150-SM2 Ground Fault Module Information.....	274
	150-SM3 Analog I/O Module Information.....	275
	Appendix B	
Option Modules	Introduction.....	279
	Cat. No. 150-SM4 Digital I/O Module	280
	Optional Cat. No. 150-SM3 Analog I/O Module.....	280
	Cat. No. 150-SM2 Positive Temperature Coefficient (PTC), Ground-Fault, and External Current Transformer Option Module.....	281
	Cat. No. 150-SM6 Parameter Configuration Module (PCM)....	287
	Appendix C	
Using DeviceLogix	Introduction.....	289
	Parameters.....	289
	Function Block Elements	289
	Macro Blocks	290
	Bit and Analog I/O Points.....	290
	Bit Inputs	291
	Bit Outputs	291
	Analog Inputs	292
	Analog Outputs.....	293
	Tips.....	293
	Data Types.....	293
	DeviceLogix Scratchpad Registers.....	293
	SMC-50 Controller DeviceLogix	
	Input Datalinks (P337...P342)	293
	Program Examples.....	293
	Example 1: Selector Switch Operation.....	293
	Example 2: Diverter Operation	295
	Example 3: Wet Well Operation.....	296
	Appendix D	
Real Time Clock (RTC) Battery Replacement	299
Index	301

About This Publication

This user manual provides you with the information that is required to program and operate your SMC-50™ soft starter.

The SMC-50 soft starter is a reduced voltage soft starter that uses a state-of-the-art microprocessor-based control module. By using six back-to-back silicon-controlled rectifiers (SCRs) (two per phase), the SMC-50 soft starter provides controlled acceleration, operation/run, and deceleration of standard three-phase squirrel-cage induction or Wye-Delta (6-lead) motors. Power structures are available with an integral bypass contactor or without (solid-state).

The user manual assumes that the installer is a qualified person with previous experience and basic understanding of electrical terminology, configuration procedures, required equipment, and safety precautions.

For safety of maintenance personnel and others who might be exposed to electrical hazards associated with maintenance activities, follow all local safety-related work practices (such as NFPA 70E, Part II in the United States). Maintenance personnel must be trained in the safety practices, procedures, and requirements that pertain to their respective job assignments.

Terminology

Throughout this publication, we also refer to the SMC-50 soft starter as the SMC-50 controller. These terms are interchangeable.

General Precautions



WARNING:

- Only personnel familiar with the controller and associated machinery should plan or implement the installation, startup, and subsequent maintenance of the system. Failure to do this may result in personal injury and/or equipment damage.
 - Hazardous voltage is present in the motor circuit even when the SMC-50 controller is off. To avoid shock hazard, disconnect the main power before working on the controller, motor, and control devices such as Start-Stop push buttons. Procedures that require parts of the equipment to be energized during troubleshooting, testing, etc., must be performed by properly qualified personnel, using appropriate local safety work practices and precautionary measures.
 - Failure of solid-state power switching components can cause overheating due to a single-phase condition in the motor. To prevent injury or equipment damage, the use of an isolation contactor or shunt trip-type circuit breaker on the line side of the SMC controller is recommended. This device should be capable of interrupting the motor's locked-rotor current.
 - Hazardous voltages that can cause shock, burn, or death are present on L1, L2, L3, T1, T2, and T3. For internal bypass units, hazardous voltages are also present on T4, T5, and T6. Power terminal covers for units rated 90...180 A (solid state) and 108...480 A (integrated bypass) can be installed to prevent inadvertent contact with terminals. Disconnect the main power before servicing the motor controller, motor, or associated wiring.
-



ATTENTION:

- Static control precautions are required when you install, test, service, or repair the assembly. The controller contains electrostatic discharge (ESD) sensitive parts and assemblies. Component damage may result if ESD control procedures are not followed. If you are not familiar with static control procedures, See applicable ESD protection handbooks.
 - Stopping modes, such as braking, are not intended to be used as an emergency stop. You are responsible for determining which stopping mode is best suited to the application. See the applicable standards for emergency stop requirements.
 - Pump and linear deceleration stopping modes may cause motor heating. Depending upon the mechanical dynamics of the system, select the lowest stopping time setting that satisfactorily stops the motor.
 - Slow speed running is not intended for continuous operation. This is due to reduced motor cooling.
 - Two peripheral devices can be connected to the direct programming interface (DPI™) port that is located in the control module. The maximum output current through the DPI port is 560 mA.
NOTE: A Human Interface Module (HIM) located in the control module HIM port/bezel (See [Figure 9](#)) also draws power from the DPI port.
 - Disconnect the controller from the power source when installing or inspecting protective or capacitor modules. These modules should be inspected periodically for damage or discoloration. Replace module if it is damaged or the clear sealant or components are discolored.
 - Additional considerations may be required for EMC compliance. See [Electromagnetic Compatibility \(EMC\) on page 42](#).
-



ATTENTION:

- The controller must be correctly applied and installed. If applied or installed incorrectly, damage to the components or the reduction in product life may occur. The system may malfunction if the following wiring or application errors occur: undersizing the motor, using an improperly sized controller, using an incorrect or inadequate AC supply, excessive ambient temperatures, or power quality.
 - You must program the Motor Overload parameter to provide proper protection. Overload configuration must be properly coordinated with the motor.
 - This product has been designed and tested as Class A equipment for electromagnetic compatibility (EMC). Use of this product in domestic environments may cause radio interference, in which case, the installer may need to employ additional mitigation methods.
 - Disconnect the controller from the motor before you measure insulation resistance (IR) of the motor windings. Voltages used for insulation resistance testing can cause silicon-controlled rectifier (SCR) failure. Do not make any measurements on the controller with an insulation resistance (IR) or Megger tester.
 - To protect the Smart Motor Controller (SMC) and/or motor from line voltage surges, protective modules may be placed on the line, load, or both sides of the SMC controller. **Do not place protective modules on the load side of the SMC controller** when using an inside-the-delta motor connection or with pump, linear deceleration, or braking control.
 - The controller can be installed on a system with power factor correction capacitors (PFCC). **The PFCCs must only be on the line side of the SMC controller.** Installing PFCCs on the load side results in SCR damage and failure.
 - The ground fault sensing feature of the SMC-50 controller is intended for monitoring purposes only and not as a ground fault circuit interrupter for personnel protection as defined in Article 100 of the NEC. The ground fault sensing feature has not been evaluated to UL 1053.
 - After a short circuit occurs, you **must** verify device functionality.
-



This product contains a sealed lithium battery that may need to be replaced during the life of the product.

At the end of its life, the battery that is contained in this product should be collected separately from any unsorted municipal waste.

The collection and recycling of batteries helps to protect the environment and contributes to the conservation of natural resources as valuable materials are recovered.

Perchlorate material – special handling may apply. See www.dtsc.ca.gov/hazardouswaste/perchlorate.

This perchlorate warning only applies to primary Lithium Manganese Dioxide (LiMnO₂) cells or batteries, and products containing these cells or batteries, sold or distributed in California, USA.



ATTENTION: There is a danger of explosion if the lithium battery or real-time clock module in this product is incorrectly replaced. Do not replace the battery or real-time clock module unless power has been removed and the area is known to be nonhazardous.

Replace the battery only with an equivalent CR2032 coin-cell battery.

Do not dispose of the lithium battery or real-time clock module in a fire or incinerator. Dispose of used batteries in accordance with local regulations.

For safety information on the handling of lithium batteries, including handling and disposal of leaking batteries, see Guidelines for Handling Lithium Batteries, publication [AG 5-4](#).

Summary of Changes

This manual includes new information about the SMC-50 controller with internal bypass option. It also updates and corrects information from previous revisions.

This manual includes enhanced information about operating modes, wiring, and application profiles.

This manual removes information about specifications, spare parts, and accessories that has moved to the technical data publication, [150-TD009](#).

Additional Resources

These documents contain additional information concerning related products from Rockwell Automation.

Resource	Description
SMC-50 Controller Quick Start Guide, publication 150-0S003	Provides basic setup information for the SMC-50 controller.
SMC-50 Controller Technical Data, publication 150-TD009	Provides comprehensive selection and technical information for SMC-50 controller and accessories.
Enclosed SMC Controllers Selection Guide, publication 150-SG012	Provides selection information about enclosed SMC controller products.
SMC-50 Control Module Replacement Instructions, publication 150-IN078	Provides instructions for replacing the SMC-50 control module.
PowerFlex™ 20-HIM-A6 and 20-HIM-C6S HIM (Human Interface Module) user manual, publication 20HIM-UM001 .	Provides comprehensive user information for 20-HIM human interface modules.
20-COMM-D DeviceNet Adapter user manual, publication 20COMM-UM002 .	Provides comprehensive user information for 20-COMM-D DeviceNet adapter.
20-COMM-C Series B / 20-COMM-Q Series A ControlNet Adapter user manual, publication 20COMM-UM003 .	Provides comprehensive user information for 20-COMM-C ControlNet and 20-COMM-Q ControlNet (Fiber) adapters.
20-COMM-P Profibus® Adapter user manual, publication 20COMM-UM006 .	Provides comprehensive user information for 20-COMM-P Profibus adapter.
20-COMM-S RS-485 DF1 Adapter user manual, publication 20COMM-UM005 .	Provides comprehensive user information for 20-COMM-S RS-485 DF1 adapter.
20-COMM-I Interbus Adapter user manual, publication 20COMM-UM007 .	Provides comprehensive user information for 20-COMM-I Interbus adapter.
PowerFlex 20-COMM-E EtherNet/IP Adapter user manual, publication 20COMM-UM010 .	Provides comprehensive user information for 20-COMM-E EtherNet/IP adapter.
20-COMM-ER Dual-Port EtherNet/IP™ Communication Adapter user manual, publication 20COMM-UM015 .	Provides comprehensive user information for 20-COMM-ER Dual-Port EtherNet/IP Communication adapter
20-COMM-H RS485 HVAC Adapter user manual, publication 20COMM-UM009 .	Provides comprehensive user information for 20-COMM-H RS485 HVAC adapter.
20-COMM-K CANopen Adapter user manual, publication 20COMM-UM012 .	Provides comprehensive user information for 20-COMM-K CANopen adapter.
Product Certifications website, http://www.rockwellautomation.com/global/certification/overview.page	Provides declarations of conformity, certificates, and other certification details.

You can view or download publications at <http://www.rockwellautomation.com/global/literature-library/overview.page>. To order paper copies of technical documentation, contact your local Allen-Bradley distributor or Rockwell Automation sales representative.

Product Overview

Introduction

The SMC-50™ Smart Motor Controller is a micro-processor based soft starter that is designed to maximize the efficiency of motor starts and stops. The SMC-50 controller uses six silicon-controlled rectifiers (SCRs) (two per phase) to vary the conduction period and control the voltage (torque) to the motor during starting, running, and stopping. The starter has many advanced power monitoring and motor/starter protection features to help increase overall reliability. Product scalability is enabled by its three connection ports (Port 7, 8, and 9) to house additional I/O, network communication, or parameter configuration modules (a maximum of three modules). Scalability continues into the configuration of the controller via different options: a multilingual 20- HIM-A6 controller or a panel-mount keypad with LCD display featuring more advanced configuration features, and software that is PC based and network capable (such as Connected Components Workbench™ Software) with optimal configuration features. The front panel of the SMC-50 controller features a single, multicolored LED status indicator that provides both diagnostics and controller status information and a Push-to-Reset/Hold-to-Test push button which allows manual reset of an actual fault condition, and initiates a tuning cycle or test for fault.

Figure 1 - SMC-50 Controller Indicators and Port Locations

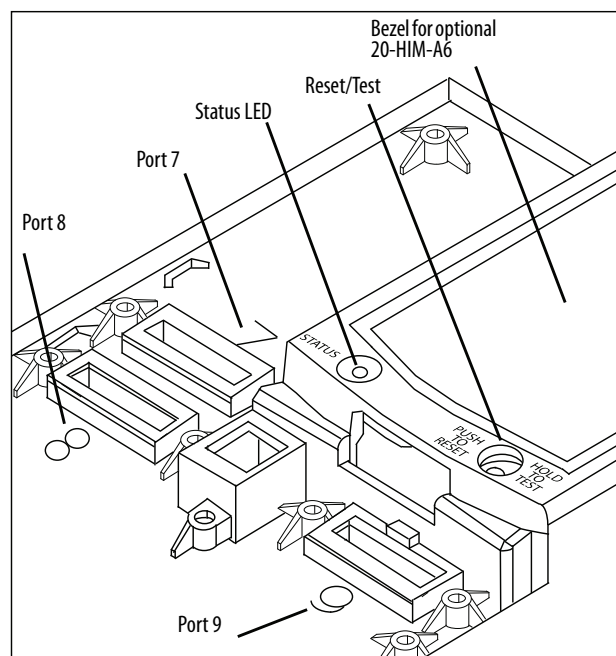

Features

- Internal bypass or solid-state control available
- 108...480 A range for devices with internal bypass; 90...520 A range for solid-state devices
- Rated voltage: 200...690V AC
- Nine standard start modes
- Three expansion ports to install option modules
- Built-in electronic motor overload protection
- Current and voltage sensing on each phase
- Metering
- DPI Communication Protocol
- Parameter configuration options
- Energy saver mode
- Logging of the last 100 events with time stamp
- Network communication (option)
- External bypass as an option
- Conformally coated PCBs

Starting Modes

The SMC-50 Smart Motor Controller provides the following starting modes of operation as standard:

Starting Modes	
Soft Start	Pump Control Mode
Linear Speed Acceleration	Dual Ramp Start
Torque Control Start	Full Voltage Start
Current Limit Start	Preset Slow Speed
Selectable Kickstart	Integral Motor Winding Heater (starting feature)

Soft Start

This method covers the most general applications. The motor is given an initial torque setting, which is user adjustable. From the initial torque level, the output voltage to the motor is steplessly increased (ramped) during the acceleration ramp time, which is user-adjustable. A user-adjustable current limit value is also available. This limits the current throughout the soft start.

TIP A motor's torque curve is not a linear function and depends on both applied voltage and current. As such, if the soft starter ramped voltage applied to the motor is sufficient for it to develop torque high enough to overcome the inertia of the load, the motor could quickly accelerate to full speed in less than the configured ramp time when using the Soft Start mode.

Figure 2 - Soft Start Timing Diagram

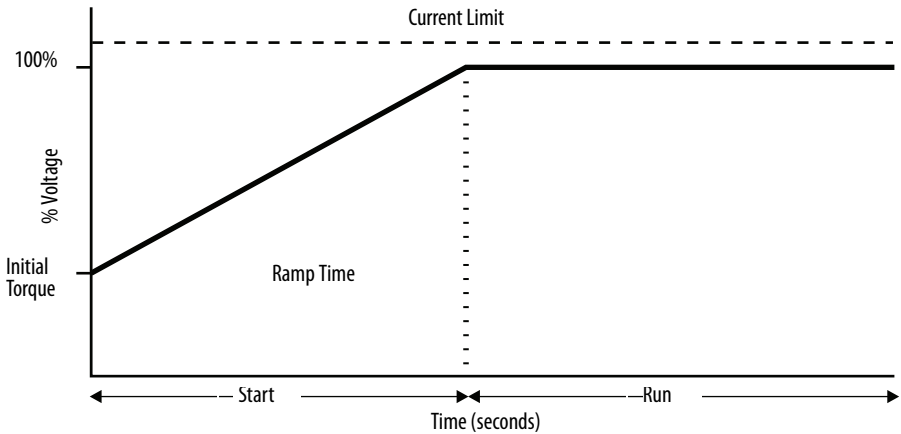

Linear Speed Acceleration

With this type of starting mode, the motor acceleration is at a constant rate. The controller accelerates the motor in a linear fashion from the off (0 speed) condition to full speed condition in the time configured in the user-defined ramp time. This is done using a proprietary motor speed feedback algorithm to sense motor speed.

- NOTE: An external speed sensor is NOT required.

This starting mode presents the least amount of stress on mechanical components. An initial torque value is configured to define a motor starting value. A current limit value is also available to limit the starting current throughout the linear acceleration start maneuver.

Figure 3 - Linear Speed Acceleration Timing Diagram

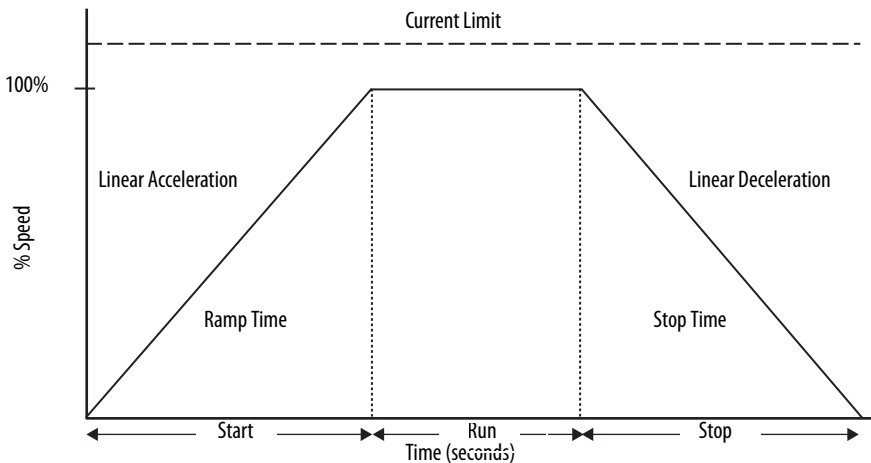

Torque Control Start

This method provides a torque ramp from a user-adjustable, initial motor starting torque to a user-adjustable, maximum torque over the defined starting ramp time. The torque control mode provides a more linear starting ramp than a soft start, potentially resulting in less stress on mechanical components and a more time controlled ramp. A current limit value is also available to limit the starting current throughout the torque start.

Figure 4 - Torque Control Start Timing Diagram

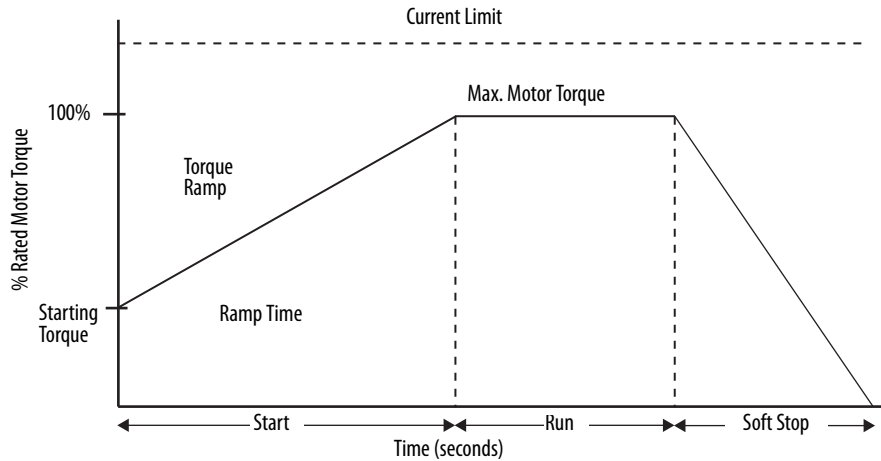

Current Limit Start

This method provides a current limit controlled start by maintaining a constant current to the motor and is used when it is necessary to limit the maximum starting current. The starting current and current limit starting ramp time is user-adjustable. Current Limit Start can also be used in conjunction with Soft Start, Torque Control, and Linear Speed Acceleration Starts.

Figure 5 - Current Limit Start Timing Diagram

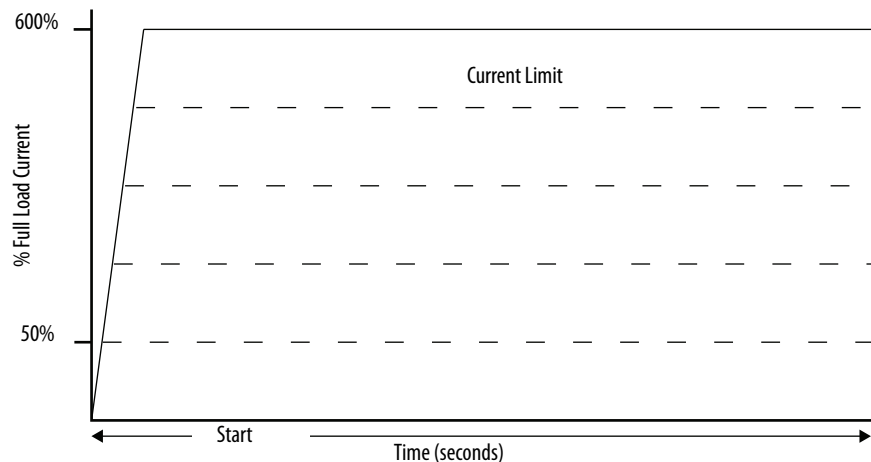

Selectable Kickstart

The kickstart feature provides a boost at startup to break away loads that may require a pulse of current/torque to get started. It is intended to provide a current/voltage pulse for a short period of time. Kickstart is available in Soft Start, Current Limit, Pump, and Torque Control modes.

Figure 6 - Selectable Kickstart Timing Diagram

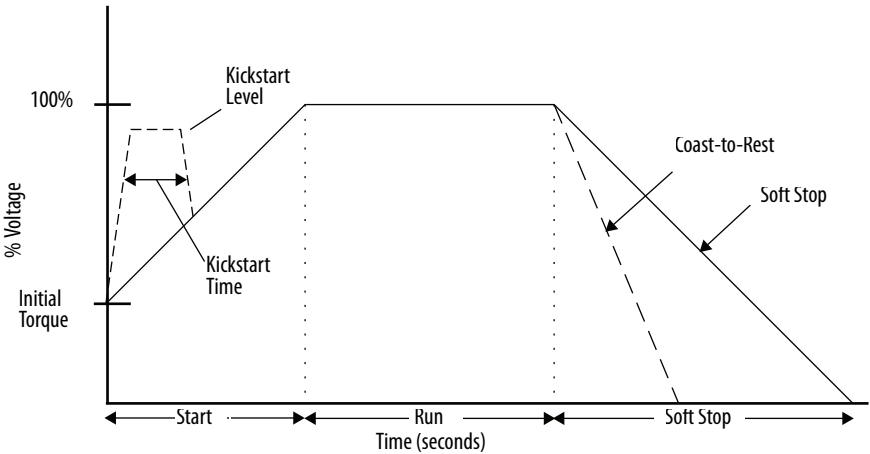

Pump Control Mode

This mode is used to reduce surges in a fluid piping system and the resulting fluid hammer or check valve slam caused by starting a centrifugal pump at full voltage and full speed. This mode also reduces pump cavitations, increasing pump life. To provide these benefits, the SMC-50 controller’s microprocessor generates a motor starting curve which follows the starting characteristics of a centrifugal pump and monitors operation during start to ensure reliable pump starts.

Figure 7 - Pump Control Mode Timing Diagram

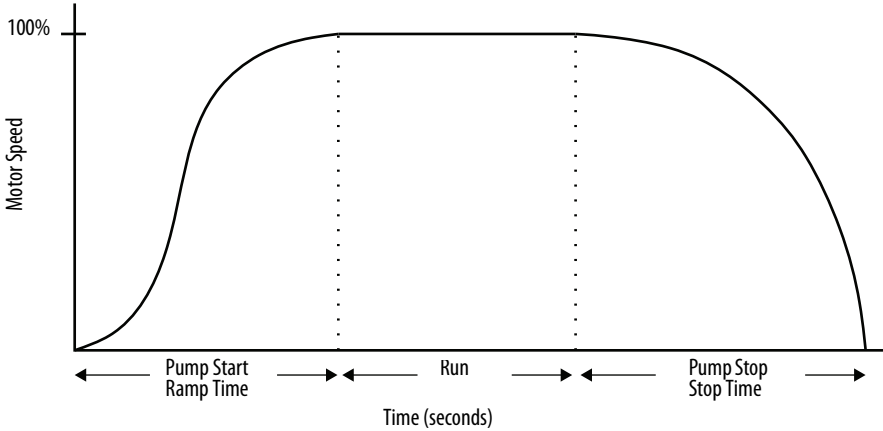

Dual Ramp Start

This method is useful on applications with varying loads, starting torque, and start time requirements. Dual Ramp Start gives you the ability to select between two separate start profiles via any programmable auxiliary input. Each start profile can use any of the available starting modes.

Figure 8 - Dual Ramp Start Timing Diagram

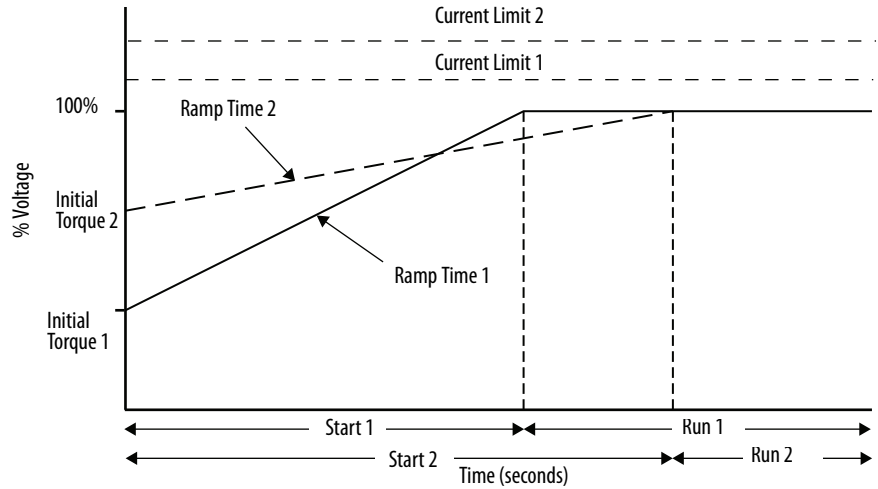

Full Voltage Start

This method is used in applications requiring across-the-line starting. The SMC-50 controller performs like a solid-state across-the-line contactor. Full inrush current and locked-rotor torque are realized. The SMC-50 controller may be programmed to provide a full voltage start in which the output voltage to the motor reaches full voltage in five cycles.

Figure 9 - Full Voltage Start Timing Diagram

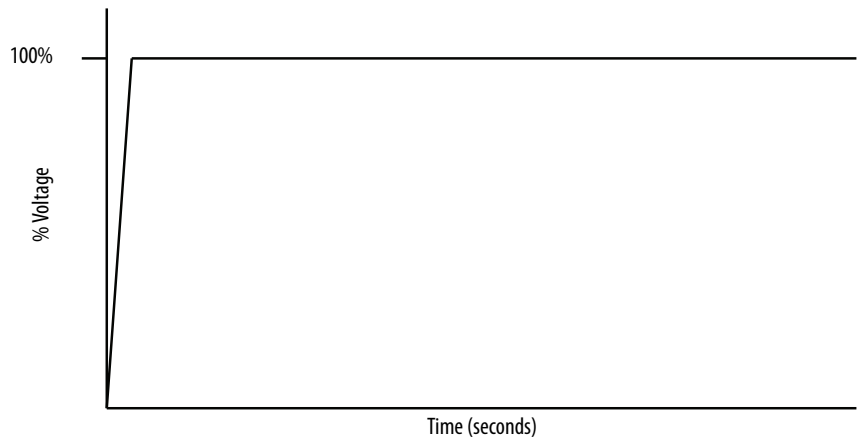

Preset Slow Speed

This feature/function can be used on applications that require slow speed moves for positioning material. The Preset Slow Speed can be set from 1% (low), up to 15% (high) in 1% increments of base speed. Forward or reverse movement is enabled through programming the sign (\pm) of the percent speed. No reversing contacts are required. To ensure accurate stops, braking is also a part of this function. Two independent preset slow speed parameters can be programmed for both speed and direction.

Figure 10 - Preset Slow Speed Timing Diagram

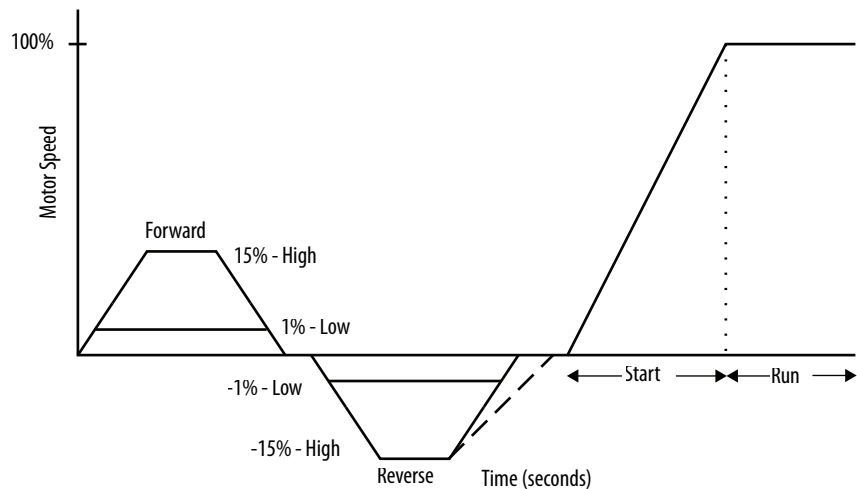

Integral Motor Winding Heater (starting feature)

This function eliminates the need for additional hardware to heat the motor from a cold start and enables using a small amount of motor current switched to each motor phase in sequence to heat the windings. Heating can be time based or activated by configurable input. The winding heat level is also configurable.

Stopping Modes

The SMC-50 Smart Motor Controller provides the following Stopping Modes of operation as standard:

Stopping Modes	
Coast	Linear Speed Deceleration
Soft Stop	Pump Stop

Coast

Configuring the stop mode to coast sets the controller to perform a motor coast-to-stop maneuver.

Figure 11 - Coast-to-Stop Timing Diagram

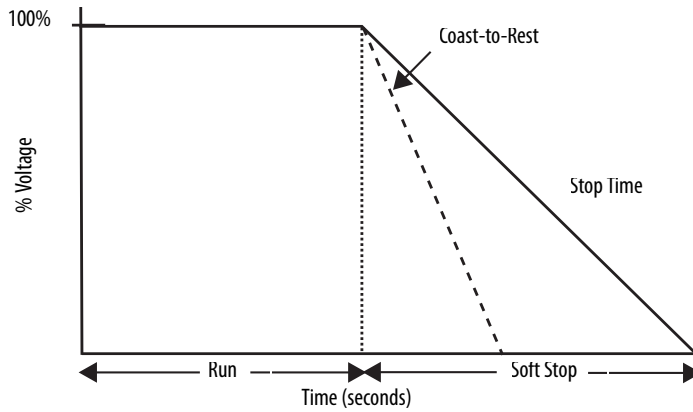

Soft Stop

The Soft Stop mode can be used in applications requiring an extended stop time. The voltage ramp down time is user-adjustable from 0...999 seconds. This load stops when the programmed stop time has elapsed or the voltage ramp drops to a point where the load torque is greater than the motor torque.

Figure 12 - Soft Stop Timing Diagram

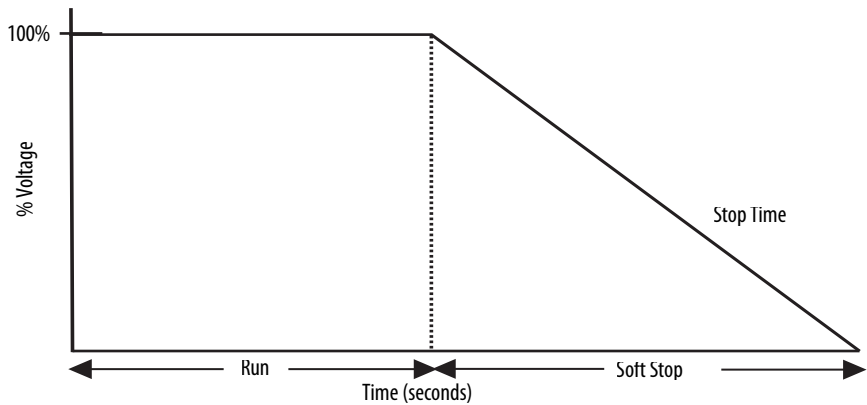

Linear Speed Deceleration

Configuring the motor stop mode to Linear Speed Deceleration mode commands the motor to stop from full speed to zero speed following a linear ramp based on the user-configured stop time. A current limit value is also available to limit the stopping current throughout the Linear Speed Deceleration maneuver.

Figure 13 - Linear Speed Deceleration Timing Diagram

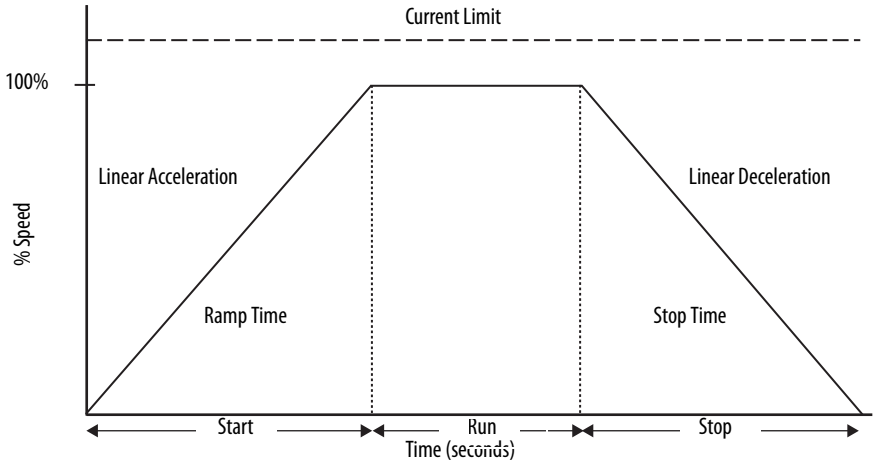

Pump Stop

Just as starting a centrifugal pump at full voltage causes fluid hammer and check valve slam, stopping a centrifugal pump that is running at full speed can also produce the same results. The SMC- 50 controller's Pump Stop mode generates a motor stop curve, which follows the stop characteristics of a centrifugal pump. This results in the gradual decrease in motor speed.

Figure 14 - Pump Stop Timing Diagram

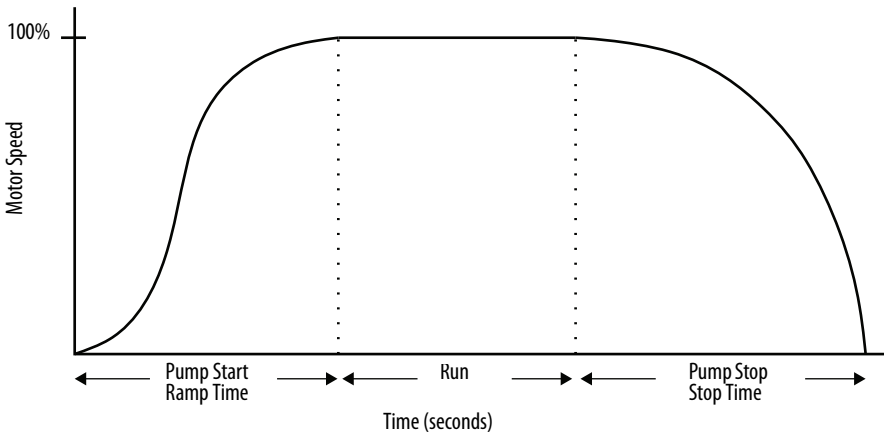

Braking Control Modes⁽¹⁾

The SMC-50 Smart Motor Controller provides the following braking control modes of operation as standard:

Braking Control Modes	
SMB—Smart Motor Braking	Accu-Stop
Slow Speed with Braking	External Braking Control

(1) Not intended to be used as an emergency stop. Refer to the applicable standards for emergency stop requirements.

SMB—Smart Motor Braking⁽¹⁾

This mode provides motor braking for applications that require the motor to stop faster than a coast-to-rest. Braking control with automatic zero speed shutoff is fully integrated into the design of the SMC-50 controller. This design facilitates a clean, straight-forward installation and eliminates the requirement for additional hardware (for example, braking contactors, resistors, timers, and speed sensors). The micro-processor based braking system applies braking current to a standard squirrel-cage induction motor. The strength of the braking current is programmable from 0...400% of full-load current.

Figure 15 - SMB Timing Diagram

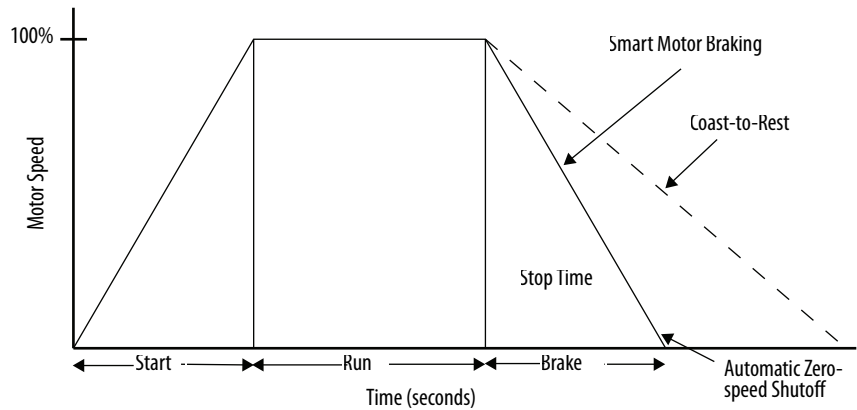

Slow Speed with Braking⁽¹⁾

Slow Speed with Braking is used on applications that require slow speed (in the forward or reverse direction) for positioning or alignment and also require braking control to stop. Slow Speed adjustments are $\pm 1\% \dots \pm 15\%$ in 1% increments of base speed. Braking current is adjustable from 0...400%.

Figure 16 - Slow Speed with Braking Timing Diagram

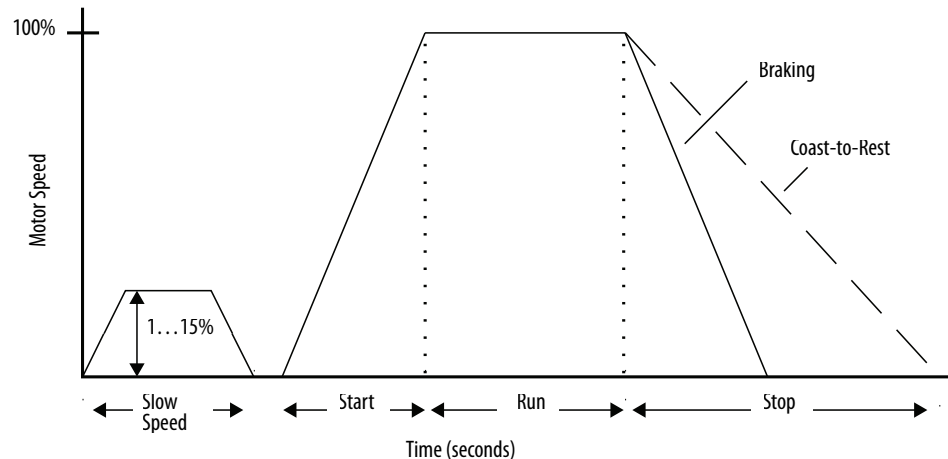

(1) Not intended to be used as an emergency stop. Refer to the applicable standards for emergency stop requirements.

Accu-Stop⁽¹⁾⁽²⁾

This control is used in applications requiring controlled position stopping. During stopping, braking torque is applied to the motor until it reaches the configured preset slow speed value ($\pm 1\% \dots \pm 15\%$) and holds the motor at this speed until a stop command is given. Braking torque is then applied until the motor reaches zero speed. Braking current is programmable from 0...400% of full-load current.

Figure 17 - Accu-Stop Timing Diagram

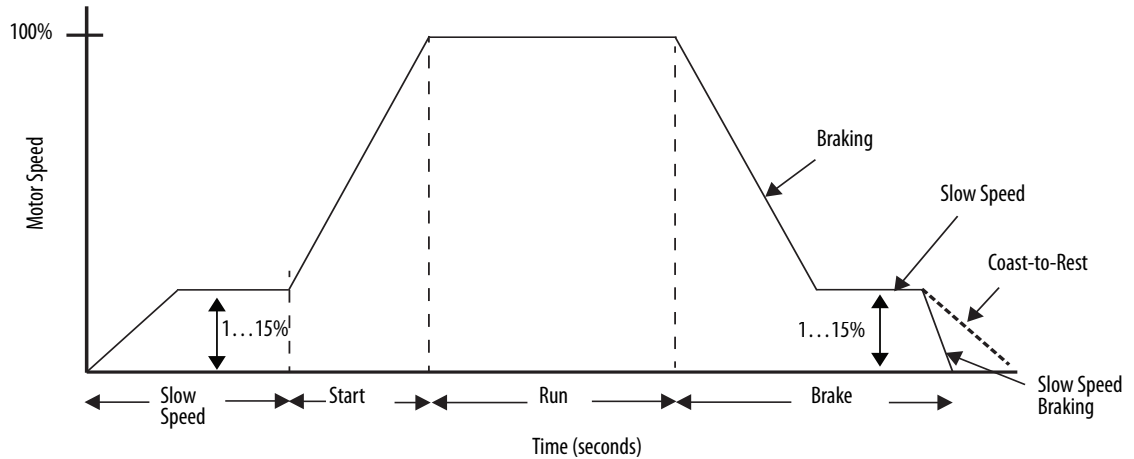

External Braking Control⁽¹⁾

An external braking device can be used to externally brake a motor controlled by the SMC-50 controller. The external braking device is activated using one of the SMC-50 controller's auxiliary relays configured for "Ext Brake" with the stop mode parameter set to "Ext Brake". The relay is energized when the "Stop" command is given and stays on until the time configured in the "Stop Time" parameter counts down to zero.

Internal Bypass Modes

The SMC-50 controllers with internal bypass uses its power section SCRs to start and stop a squirrel-cage induction motor. The basic operation of the SCRs is to switch on (conduct) for a certain percentage of the 50/60 Hz AC sine wave to control the amount of voltage applied to the motor. By using special control algorithms and motor feedback to manage the voltage applied, the SMC-50 controller can perform various starting, stopping and braking control modes as outlined in previous sections of this document. During normal run operation the SMC-50 controller with internal bypass closes the internal bypass contactor(s) when the motor is up-to-speed. This reduces heat because the motor current is now flowing through the internal bypass contactor and not through the SCRs.

- (1) Not intended to be used as an emergency stop. Refer to the applicable standards for emergency stop requirements.
- (2) Accu-Stop is not included as a parameter/function like that of the SMC-Flex. However, the Accu-Stop function can be accomplished with the Smart Motor Braking Stop Option and Slow Speed with Braking functions.

Solid-state Running Modes

The SMC-50 controllers with solid-state power structures provide the following running modes of operation as standard:

Running Modes	
SCR Control—Normal Run Operation	External Bypass—Optional Run Operation
SCR Control—Energy Saver Run Operation	Emergency Run

- Note: These modes are only available on solid-state power structures. They are not available on units with internal bypass.

SCR Control - Normal Run Operation

The SMC-50 controller uses its power section SCRs to start, run, and stop (except for Coast-to-Stop) a squirrel-cage induction motor. The basic operation of the SCRs is to switch on (conduct) for a certain percentage of the 50/60 Hz AC sine wave, as directed by the SMC-50, to control the amount of voltage applied to the motor. By using special control algorithms and motor feedback to manage voltage supplied, the SMC-50 controller provides the previously outlined motor starting, stopping, and braking control modes. During the normal run operation, the SMC-50 controller power section SCRs are conducting for 100% of the 50/60 Hz AC sine wave to provide the motor specified full load current (FLA/FLC) voltage and the resulting torque.

SCR Control – Energy Saver Run Operation

The Energy Saver Run Operation function is typically used in applications where the running motor is lightly loaded or unloaded for an extended period of time. With the Energy Saver Run Operation function enabled, the SMC-50 controller continuously monitors motor load using internal feedback to control its SCRs, which reduces the voltage applied to the motor. This potentially reduces power consumption. A parameter is provided to display the possible energy saved as a percent.

External Bypass – Optional Run Operation

An external bypass contactor can be used to carry the motor running current. In this running mode, the SCRs are only used for starting and potentially stopping depending on the stop mode selected. The SMC-50 controller controls the external bypass using one of its auxiliary relay outputs. When the SMC-50 controller is used in the external bypass mode with the contacts of the external bypass contactor closed, you have the option of using the SMC-50 controller's internal or external current sensing capabilities. If using external current sensing so that metering, alarm/fault, etc. conditions are reported to the controller during run operation, an external Bulletin 825-MCM Converter Module is required to interface with the 150-SM2 Option Module. This configuration enables the SMC-50 controller's current-related motor protection features to be used (for example, external overload not required).

- NOTE: If this configuration is not used, a means of external motor protection is required when using an external bypass contactor.

If the bypass kit is used (Frames C and D only), the SMC-50 controller is used for current sensing, metering, alarm/fault conditions, etc. and neither a Bulletin 825-MCM converter module nor a Cat. No. 150-SM2 are required.

Emergency Run

When one of the SMC-50 controller's inputs is configured for Emergency Run and that input is activated, all system faults are disabled. This prevents the system from being shut down by a fault.

Resistor Loads

The SMC-50 solid-state controller can control directly connected resistive loads utilizing phase angle control based on a reference value. If this control method is selected the SMC-50 controller varies the output voltage in response to the changing reference source. This reference source is programmable and extremely flexible. This mode is typically used for resistive heating applications.

Motor and Starter Protection Features



The SMC-50 controller provides both motor and starter alarms and faults. An alarm condition is intended to provide an alert that a potential system issue, or fault is pending to allow time to take corrective action. A fault is intended to protect equipment from damage by shutting that equipment down and/or removing power. The SMC-50 controller lets you individually enable

or disable motor and starter alarms and faults by bit (On/Off) selection. Alarm and fault trip points are typically user-configurable to allow for application dependence. In addition, many alarms and faults provide a separate user-configurable alarm and fault time delay parameter to limit nuisance trips and shutdowns.

The SMC-50 controller has a separate Fault Buffer and Alarm Buffer to maintain a Fault/Alarm history. In addition to the fault/alarm code and description, a time and date stamp is provided by the SMC-50 controller's Real

Time Clock (RTC). The Fault Buffer holds the last five faults which provide the time and date; the Alarm Buffer holds the last 100 alarm events which detail the time, date, parameter change, Start, Stop, Coast, Slow Speed Operation, Alarm, Fault, and Fault Reset.

As standard, the SMC-50 controller enables manual reset of a fault from the PUSH-TO-RESET/HOLD-TO-TEST button, located adjacent to the LED status indicator. Fault indication and reset can also be performed from an optional controller bezel and/or panel-mount HIM or from PC software (such as Connected Components Workbench software).

Starter Protection Features

Undervoltage Protection

The SMC-50 controller's Undervoltage Protection can sound an alarm or halt (fault) motor operation if a drop in the incoming line voltage is detected. The undervoltage trip level is adjustable as a percentage of the programmed line voltage from 0...100%. To eliminate nuisance trips, a programmable undervoltage trip delay time of 0.1...99.0 seconds can also be programmed. The line voltage must remain below the undervoltage trip level during the programmed delay time.

Overvoltage Protection

If a rise in the incoming line voltage is detected, the SMC-50 controller's Overvoltage Protection can sound an alarm or halt (fault) motor operation. The overvoltage trip level is adjustable as a percentage of the programmed line voltage, from 100...199%. To eliminate nuisance trips, a programmable overvoltage trip delay time of 0.1...99.0 seconds can also be programmed. The line voltage must remain above the overvoltage trip level during the programmed delay time.

Voltage Unbalance Protection

Voltage unbalance is detected by monitoring the three-phase supply voltage magnitudes in conjunction with the rotational relationship of the three phases. The SMC-50 controller halts motor operation when the calculated voltage unbalance reaches the user-programmed trip level. The voltage unbalance trip level is programmable from 0...25% unbalance.

In addition to the faults and alarms that were already discussed, the following are also available:

- Phase Reversal (CBA Connection)
- Parameter Configuration Change
- Frequency High and Low
- Open SCR Gate
- Line Loss with Phase Identification
- Poor Voltage Power Quality—THD V

Metering System

Power and operational monitoring parameters include:

- **Current**—The RMS current value is provided for each phase, plus the average current of all three.
- **Voltage**—The RMS line-to-line and line-to-neutral voltage values are provided while the motor is running and when stopped. The average of all three is also provided.
- **Line Frequency**—The SMC-50 controller measures and provides user access to the line frequency (Hz).
- **Power**—Real, reactive, and apparent power values are calculated for each phase plus the total for all 3 phases. In addition, the current power demand and the maximum power demand is provided.
- **Power Factor**—The value of the power factor is provided for each phase and as a total of all three.
- **Peak Starting Current**—The SMC-50 controller stores the peak average RMS motor current consumed for the last 5 start cycles.
- **Total Harmonic Distortion (THD)**—The SMC-50 controller calculates and provides user access to the THD for the 3 line voltages and 3 motor currents, along with the average value of each.
- **Voltage Unbalance**—The calculation of the voltage unbalance signal is provided.
- **Current Imbalance**—The calculation of the current imbalance signal is provided.
- **Energy Savings**—The SMC-50 controller provides the percentage of energy saved when it is running the motor in the Energy Savings mode.
- **Motor Torque**—Electromechanical motor torque is calculated based on current and voltage feedback from the motor.
- **Motor Speed**—The SMC-50 controller provides a calculated estimate of motor speed in percent of full speed when operating in the linear speed acceleration starting or deceleration stopping mode.
- **Elapsed Time and Elapsed Time 2**—An elapsed time meter is provided to account for the total accumulated hours the motor has been running. You can reset the meter. Elapsed Time 2 cannot be user reset and holds after 50,000 hours have elapsed.
- **Running Time**—The running time meter accumulates time (in hours) from the point the motor start command is given up to the point the motor stop command is issued. When a new start command is given, the meter resets to zero and begins accumulating time again.
- **Actual Start Time**—The unit stores the actual time it takes to complete a start cycle (motor start command issued until motor is up-to speed). The last five start times are stored as parameters for user access and in the Alarm Buffer as events.
- **Total Starts**—The total starts counter increments on every successful start (no prestart fault occurred) and cannot be reset. The maximum value is 65,635.

Communications

Figure 18 - SMC-50 Controller Control Module—Shown without Cover

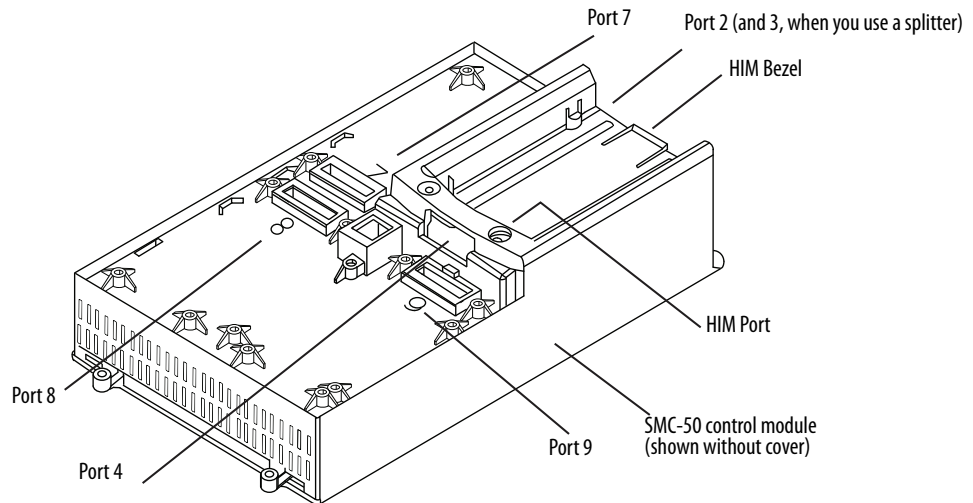

Device Peripheral Interface (DPI) Protocol

The SMC-50 Soft Starter communicates in the same manner as the Allen-Bradley® SMC Flex™ and drive products using the DPI protocol. This enables almost any DPI-supported Human Interface Module (HIM), PC software (such as Connected Components Workbench software), or network communications module (20-COMM-xx) to be used with the SMC-50 controller. The SMC-50 controller supports four DPI ports for communication devices. Port #1 is located in the controller bezel for the front-mounted HIM. Port #2, located on the top of the controller, supports a second and third device via Port #3 when a DPI splitter is used. Port #4, located directly below the controller bezel, is dedicated to a 20-COMM-xx network communications module when inserted into the space allotted for controller option Port #9. All four communication ports can be used simultaneously.

DeviceLogix™

DeviceLogix is an embedded control technology in selected Allen-Bradley products that can control outputs and manage status information on board a device. The SMC-50 controller with DeviceLogix technology can help improve system performance and productivity by controlling outputs and managing status and information within the SMC-50 controller. Processing information within the controller can speed up reaction time, which reduces dependency on network throughput and provides an option for decision making if communication with the main controller is lost.

Motor Protection Features

Electronic Motor Overload Protection

As standard, the SMC-50 controller incorporates electronic motor overload protection. This is accomplished electronically with an I^2t algorithm. Overload Protection is intended to protect the motor, motor controller, and power wiring against overheating caused by excessive overcurrent. The SMC-50 controller meets applicable requirements as a motor overload protective device. It is not intended to protect against a short-circuit condition.

The SMC-50 controller's overload protection is programmable, providing you maximum flexibility. The Overload Trip class is either OFF or is configurable from 5 to 30. The overload is programmed by entering the motor full-load current rating, service factor, and selecting the trip class. Thermal memory accurately models motor operating temperature. Ambient temperature insensitivity is inherent in the electronic design of the overload. You can also set a timer to disable the overload function during motor starts; another timer lets you monitor the amount of time remaining before the overload trip occurs. Manual or automatic reset of an overload is configurable.

Stall Protection and Jam Detection

Motors can experience locked-rotor currents and develop high torque levels in the event of a stall or a jam. These conditions can result in winding insulation breakdown or mechanical damage to the connected load. The SMC-50 controller provides both stall protection and jam detection for enhanced motor and system protection. A jam level (as a percent of motor FLC) is configurable for both an alarm and motor shutdown (fault). In addition, both stall and jam conditions provide the ability to set a delay time before initiating an alarm (jam only) or motor shutdown (fault).

Underload Protection

Utilizing the Underload Protection of the SMC-50 controller, an alarm can be sounded or motor operation can be halted (fault) if a drop in current is sensed.

The SMC-50 controller provides an adjustable underload trip setting from 0...99% of the programmed motor full-load current rating with an adjustable trip delay time of 0.1...99.0 seconds.

Excessive Starts Per Hour

The SMC-50 controller lets you program the allowed number of starts within a one-hour sliding window (up to 99). This helps eliminate motor stress caused by repetitive starting during a short time period. An alarm or fault can be enabled using the single configured value.

User-Configurable Alarms and Faults

In addition to the previous motor alarms and faults, the following can also be configured:

- Apparent Power
- Current Imbalance
- Power Quality⁽¹⁾
- Open Load⁽¹⁾
- Power Quality Total Harmonic Distortion (THD) Current
- OverPower
 - Real
 - Reactive Consumed
 - Reactive Produced
- UnderPower
 - Real
 - Reactive Consumed
 - Reactive Produced
- Power Factor Over
 - Leading
 - Lagging
- Power Factor Under
 - Leading
 - Lagging

The SMC-50 controller also has user-configurable motor alarms and faults that you can use to indicate required or planned maintenance.

- Planned Maintenance Hours
- Planned Maintenance Starts

Controller Parameter Configuration

The SMC-50 controller's starting, stopping, and running operations are configured/programmed by changing the settings of a functionally predefined set of parameters. Several different configuration tools are available to perform this.

- NOTE: A configuration tool is not shipped with the SMC-50 controller. You must order the configuration tool separately.

(1) Contains no parameters to configure.

Configuration by Keypad and LCD Display (Human Interface Module Cat. No. 20-HIM-A6)

The upper right portion of the SMC-50 controller has a dedicated bezel and DPI port for the Cat. No. 20-HIM-A6. The 20-HIM-A6 features an LCD display to show parameter data values, detailed diagnostic alarm/fault information, numeric keypad with function keys to enter parameter data values and navigate to the different SMC-50 controller parameter menus, null parameter configuration and diagnostic display, and the ability to set up SMC-50 Controller Option Modules.



SMC-50 Smart Motor Controller with 20-HIM-A6

Optional extension cables and control cabinet door mounting kits are available to mount the HIM off the SMC-50 controller.

Configuration by PC Programmable Software

Connected Components Workbench PC software provides network connectivity between the PC and the SMC-50 controller and configurability of the full set of parameters of the SMC-50 controller. To achieve connectivity, the PC can be directly connected to the SMC-50 DPI Port #2 (or #3 using a splitter) with (1) a 1203-SSS AnaCANda™ RS232 to DPI device or (2) a 1203-USB DPI to USB device.

Parameter Configuration Option Module (Cat. No.150-SM6)

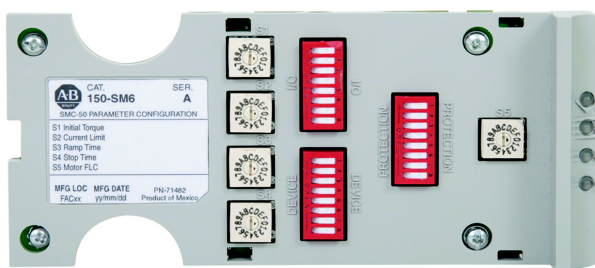

150-SM6 Parameter Configuration Module

The Parameter Configuration Option Module inserts into any one of the SMC-50 controller's three option ports (Port 7, 8 or 9). The 150-SM6 features three

sets of 8-position ON/OFF DIP switches and five sets of 16-position rotary switches. These switches allow for configuration of several key motor parameters (for example, start and stop modes, ramp time, motor FLA, etc.) for limited setup of simple applications. In addition, the 150-SM6 features three diagnostic LED status indicators to display key alarms and faults. Only one 150-SM6 is allowed per SMC-50 controller.

- NOTE: After parameter configuration is complete, the 150-SM6 can be removed from the SMC-50 controller. This enables one module to configure multiple SMC-50 controllers.

When using a Cat. No. 150-SM6 PCM to configure the SMC-50 controller, it should be noted that the following features, functions, and modes are not configurable:

- Full voltage start
- Torque ramp start
- External brake stop
- Option card I/O configuration (Cat. No. 150-SM... option modules)
- External bypass
- Specialized output relay configuration (for example, network control, DeviceLogix, auxiliary control)
- Specialized operation modes/features
 - Dual ramp, motor winding heater, emergency run
 - Overload select (Class)
 - Adjustment of slow speed set point

Parameters that are not defined and therefore are not configurable by the Cat. No. 150-SM6 PCM can be configured through other means (Human Interface Module (HIM), Connected Components Workbench Software, DriveExplorer™ or DriveExecutive™ software), if necessary.

Control Inputs and Outputs

Standard Inputs⁽¹⁾

The SMC-50 controller comes standard with two 24V DC inputs. The control functionality of each input is user-configurable as follows: Start, Coast, Stop Option (for example, Soft Stop, Pump Stop), Start/Coast, Start/Stop, Slow Speed, Overload Select, Fault Input (N.O.), Fault Input (N.C.), Clear Fault, Emergency Run, Dual Ramp Profile Select, and Start Motor Heater function. The status of any input is readable via communications.

(1) All standard and optional I/O terminal blocks are removable.

Optional Inputs⁽¹⁾

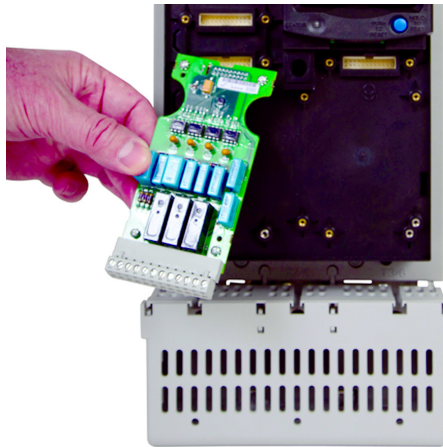

SMC-50 Smart Motor Controller with 150-SM4

A Cat. No. 150-SM4 Digital I/O option module contains four 120/240V AC inputs and can be inserted into any of the three control module option ports (three modules maximum per control module). The control functionality of each input is user configurable and identical to the standard inputs. The status of any input is readable via communications.

A Cat. No. 150-SM3 Analog I/O option module provides two analog inputs (voltage or current) and can be inserted into any of the three control module option ports (three modules maximum per control module). The control functionality of each input is user configurable. The status of any input is readable via communications.

Standard and Optional Outputs⁽¹⁾

The SMC-50 controller comes standard with two relay outputs. By adding a Cat. No. 150-SM4 Digital I/O Option Module, three additional relay outputs are provided (three option modules maximum per control module). The control functionality of each relay output is user-configurable as follows: Normal (Start Enabled), Up-To-Speed, Fault, Alarm, External Bypass, External brake, Auxiliary Control, Network 1-4, and Fan Control. Each output also includes a user-configurable on and off delay timer (10.0 seconds maximum) and the ability to invert the state of the contact. Network control of each output is also provided. By adding a Cat. No. 150-SM3 Analog I/O module, two analog outputs (voltage or current) are provided.

(1) All standard and optional I/O terminal blocks are removable.

Optional PTC, Ground Fault⁽¹⁾, and Current Transformer Interface Capability⁽¹⁾

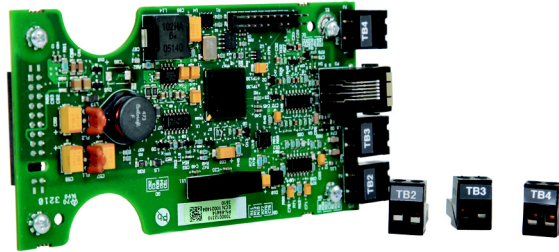

150-SM2 Option Module

The Cat. No. 150-SM2 Option Module features PTC, ground fault, and external current transformer interface capability. The PTC feature enables connection to external PTC temperature sensors

to monitor motor winding temperature and feedback data to the SMC-50. A SMC-50 controller Alarm and/or Fault can be configured to trip if the PTC set point is exceeded. The ground fault feature enables controller detection and enunciation of a possible system ground fault which could indicate a pending motor winding failure (for example, insulation breakdown). A Bulletin 825-CBCT External Ground Fault (Core Balance) Sensor is also required to interface with the 150-SM2 to fully enable this feature.

When the SMC-50 controller is used in the external bypass mode with the contacts of the external bypass contactor closed, you have the option of using the SMC-50 controller's internal or external current sensing capabilities. If using external current sensing so that metering, alarm/fault, etc. conditions are reported to the controller during run operation, an external Bulletin 825-MCM Converter Module is required to interface with the 150-SM2 Option Module.

(1) The ground fault sensing feature of the SMC-50 controller is intended for monitoring purposes only. It is not to be used as a ground fault circuit interrupter for personnel protection as defined by Article 100 of the NEC. The sensing feature has not been evaluated to UL 1053.

Wiring

This chapter illustrates basic wiring configurations for the SMC-50 controller.

Wiring Terminal Locations

The SMC-50 controller wiring terminal locations are shown in [Figure 19](#). Incoming three-phase power connections are made to terminals L1/1, L2/3, and L3/5. Load connections to motors are made to T1/2, T2/4, and T3/6.

Figure 19 - Wiring Terminal Locations

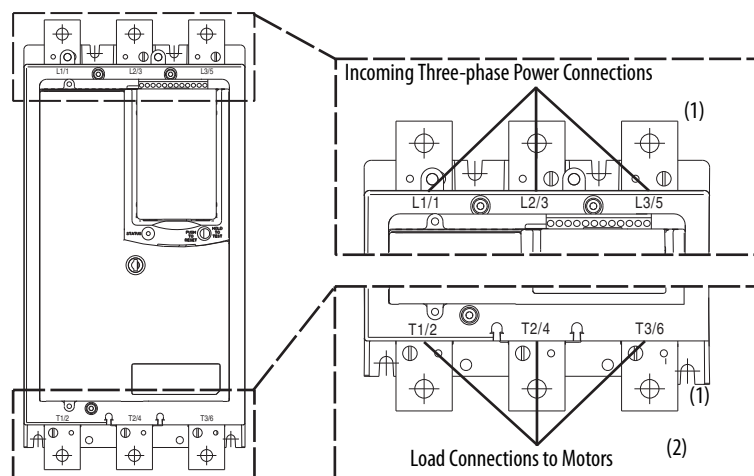

(1) See publication [150-ID009](#) for lug information.

(2) Inside-the-delta connected motors require an additional delta distribution block.

For controllers rated 210...520 A, a grounding nut (size 1/4-20) is provided for grounding per applicable local codes.

Power Wiring

See the product nameplate for device-specific information.

SMC-50 controller power structures use solid-state SCR designs that are capable of interfacing with 200...480V AC or 200...690V AC (690V line and 600V inside-the-delta) motors. Both the internally bypassed and solid-state power structures are available. Verify ratings of unit before application.

The power structure incorporates three-phase true current-sensing and overtemperature protection. You can use an external bypass contactor if it is required for your application.



ATTENTION: Failure of solid-state power switching components can cause overheating due to a single-phase condition in the motor. To prevent injury or equipment damage, the following is recommended:

Use an isolation contactor or shunt trip type circuit breaker on the line side of the SMC-50. This device should be capable of interrupting the motor's locked rotor current.

Wire the isolation contactor's control relay to an auxiliary relay output contact on the SMC-50. This will achieve coordinated operation with the SMC-50. The auxiliary relay contact should be programmed for the "normal" condition. See Chapter 5, Programming, for additional information.

Typical power wiring diagrams for both line and inside-the-delta connections are shown in [Figure 20](#).

Figure 20 - Power Wiring Diagrams

Diagrams per NEMA Symbology

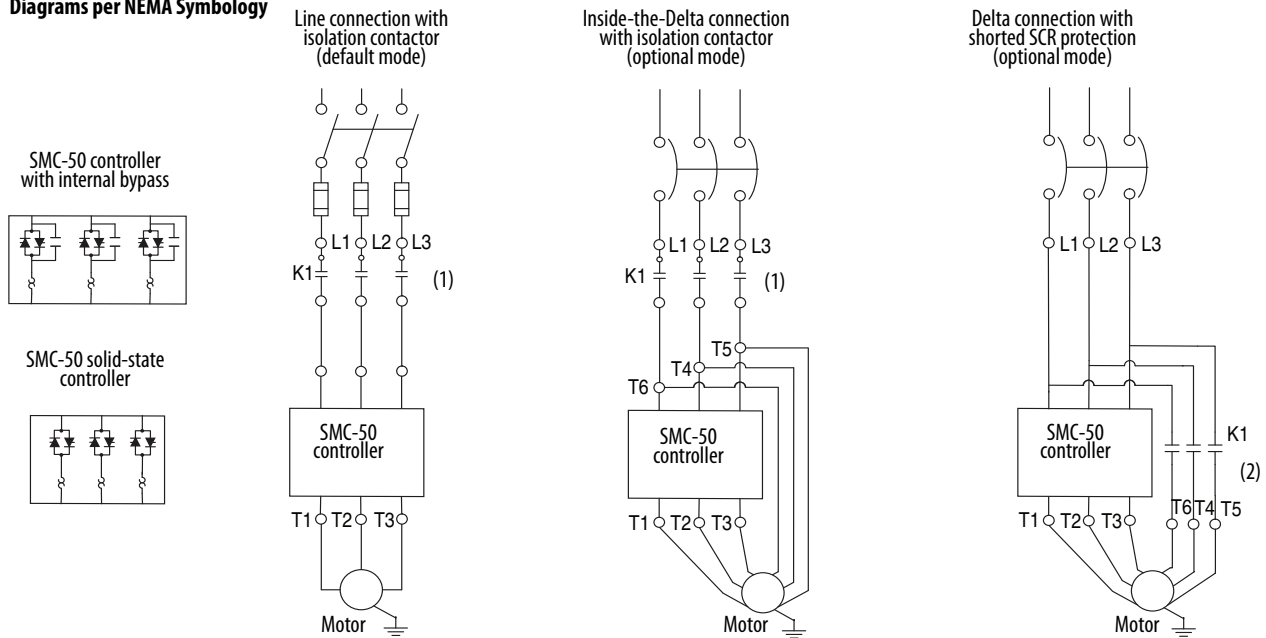

Diagrams per IEC Symbology

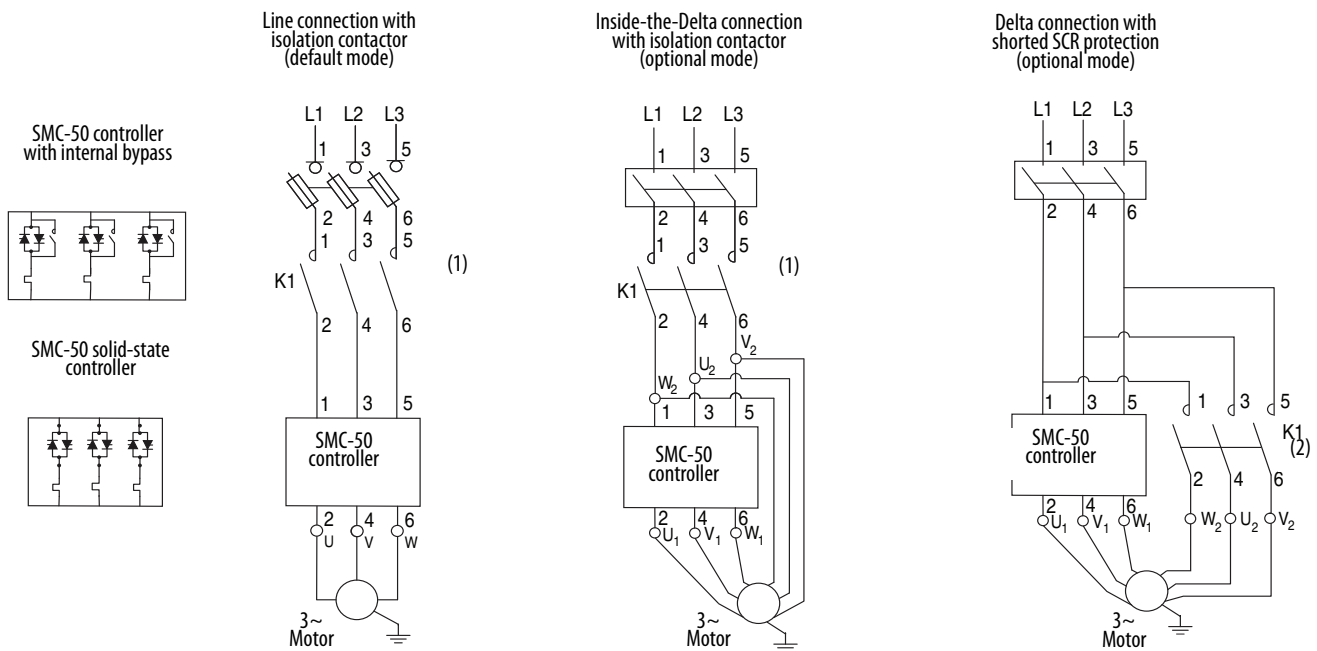

(1) Contactor must be fully rated for motor Hp/kW and FLA.

(2) For North American applications, size the contactor per the motor Hp and FLA. For IEC applications, size the contactor per the motor AC-1 or AC-3 rating. The short-circuit rating of the contactor must be similar to that of the SMC-50 controller.

Power lugs are required for devices rated 108...480 A (internal bypass) and 90...520 A (solid-state). These lugs are sold in kits. Each kit contains three lugs. [Table 1](#) through [Table 4](#) list the number and type of lugs required.

Table 1 - SMC-50 Integrated Bypass Devices Connection Lug Information for Line/Wye Connected Motors

Cat. No.	Rating [A]	Lug Kit Cat. No.	Wire Strip Length [mm]	Conductor Range	Max No. Lugs/Pole		Tightening Torque	
					Line Side	Load Side	Wire - Lug	Lug - Busbar
150-S108..., 150-S135...	108...135	199-LF1	18...20	16...120 mm ² (#6...250 MCM)	1	1	31 N•m (275 lb•in)	17 N•m (150 lb•in)
150-S201..., 150-S251...	201...251	199-LF1	18...20	16...120 mm ² (#6...250 MCM)	2	2	31 N•m (275 lb•in)	23 N•m (200 lb•in)
150-S317..., 150-S361..., 150-S480...	317...480	199-LG1	18...25	25...240 mm ² (#4...500 MCM)	2	2	42 N•m (375 lb•in)	28 N•m (250 lb•in)

Table 2 - SMC-50 Integrated Bypass Devices Connection Lug Information for Inside-the-Delta Connected Motors

Cat. No.	Rating [A]	Lug Kit Cat. No.	Conductor Range	Max No. Lugs/Pole		Tightening Torque	
				Line Side	Load Side	Wire - Lug	Lug - Busbar
150-S108..., 150-S135...	187...234	1494R-N15	25...240 mm ² (#4...500 MCM)	1	1	42 N•m (375 lb•in)	17 N•m (150 lb•in)
150-S201..., 150-S251...	348...435	1494R-N14	50...120 mm ² (1/0...250 MCM)	2	2	31 N•m (275 lb•in)	23 N•m (200 lb•in)
150-S317..., 150-S361..., 150-S480...	549...831	150-LG5MC	95...240 mm ² (3/0...500 MCM)	1	1	34 N•m (300 lb•in)	28 N•m (250 lb•in)

Table 3 - Solid-state SMC-50 Controller Power Wiring Information, Line/Wye and Inside-the-Delta Configurations

Cat. No.	Rating [A]	Lug Kit Cat. No.	Wire Strip Length [mm]	Conductor Range	Max No. Lugs/Pole		Tightening Torque	
					Line Side	Load Side	Wire - Lug	Lug - Busbar
150-SB...	90...180 (Line/Wye) 155...311 (Delta)	199-LF1	18...20	16...120 mm ² (#6...250 MCM)	1	1	31 N•m (275 lb•in)	23 N•m (200 lb•in)
150-SC...	210...320 (Line/Wye) 363...554 (Delta)	199-LF1	18...20	16...120 mm ² (#6...250 MCM)	2	2	31 N•m (275 lb•in)	23 N•m (200 lb•in)
150-SD...	361...520 (Line/Wye) 625...900 (Delta)	199-LG1	18...25	25...240 mm ² (#4...500 MCM)	2	2	42 N•m (375 lb•in)	28 N•m (250 lb•in)

Table 4 - Solid-state SMC-50 Controller Delta Distribution Block Wiring Information

Cat. No.	Tightening Torque		Quantity	Conductor Range		Wire Strip Length [mm]		Lug Kit Cat. No.
	Line	Load		Line	Load	Line	Load	
150-SB...	42 N•m (375 lb•in.)		3	25...240 mm ² (#4...500 MCM)		35	35	Allen-Bradley 1492-BG
150-SC...	67.8 N•m (600 lb•in.)	31 N•m (275 lb•in.)	1	54...400 mm ² (1/0...750 MCM)	16...120 mm ² (#6...250 MCM)	45	Top Row = 23 Bottom Row = 48	Marathon Special Products 1353703
150-SD...	67.8 N•m (600 lb•in.)	67.8 N•m (600 lb•in.)	3	54...400 mm ² (1/0...750 MCM)	54...400 mm ² (1/0...750 MCM)	45	45	Marathon Special Products 1352702

Grounding Provision

Provision for connecting a field-installed grounding conductor is provided on solid-state units that are rated 210...520 A. The grounding location is identified by the green grounding nut (size 1/4-20) that is located near the bottom mounting plate of the controller.

Protective Modules

You should install a protective module (see [Figure 21](#)) containing MOVs (Metal Oxide Varistors) to protect the SMC-50 power components from electrical transients and/or electrical noise.

You can install protective modules controllers rated from 200...600V to protect the power components from electrical transients. The protective modules clip voltage transients that are generated on the lines to prevent such surges from damaging the SCRs. The use of MOVs is highly recommended, as 480V and 600V MOVs offer maximum protection of 1400V and 1600V respectively.

- NOTE: Protective modules are not available for 690V applications.

Figure 21 - Protective Module

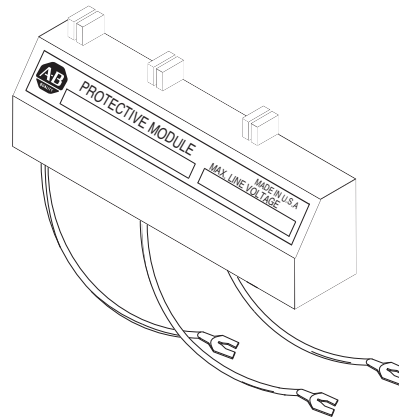

ATTENTION: You can place protective modules on the line, load, or both sides of the SMC-50 controller. However, protective modules must not be placed on the load side of the SMC-50 controller when using inside-the-delta motor connections or with pump, linear speed, or braking control.

There are two general situations that may occur that could indicate the need for using the protective modules.

1. **Transient Spikes** — Transient spikes will typically occur on the lines feeding the SMC-50 controller or feeding the load from the SMC-50 controller. Transient spikes are created on the line when devices are attached with current-carrying inductances that are open-circuited. The energy stored in the magnetic field is released when the contacts open the circuit. Examples of these include lightly loaded motors, transformers, solenoids, full voltage starters, and electromechanical brakes.
2. **Fast-rising Wavefronts** — If the SMC-50 controller is installed on a system that has fast-rising wavefronts present, although not necessarily high peak voltages, protective modules may be needed. Additionally, if the controller is on the same bus as other SCR devices (such as AC/DC drives, induction heating equipment, or welding equipment), the firing of the SCRs in those devices can cause noise.



ATTENTION: When you install or inspect the protective module, make sure that the controller has been disconnected from the power source. The protective module should be inspected periodically for damage or discoloration. Replace if necessary.

Electromagnetic Compatibility (EMC)



ATTENTION: This product has been designed for Class A equipment. Use of the product in domestic environments may cause radio interference, in which case the installer may need to employ additional mitigation methods.

The following guidelines are provided for EMC installation compliance.

Enclosure

Install the product in a grounded metal enclosure.

Wiring

Wire in an industrial control application can be divided into three groups: power, control, and signal. The following recommendations for physical separation between these groups is provided to reduce the coupling effect:

- Different wire groups should cross at 90° inside an enclosure.
- Minimum spacing between different wire groups in the same tray should be 16 cm (6 in.).
- Wire runs outside of an enclosure should be run in conduit or have shielding/armor with equivalent attenuation.
- Different wire groups should be run in separate conduits.
- Minimum spacing between conduits containing different wire groups should be 8 cm (3 in.).
- For additional guidelines, please see the installation instructions, Wiring and Ground Guidelines, publication [DRIVES-IN001](#).

Additional Requirements

- Wire earth ground to control terminal #3 control ground.
- Use shielded wire for PTC and ground fault input.
- Terminate shielded wires to the control module terminal #3 control ground.
- Ground fault CT must be inside or within 3 m (9.84 ft.) of metal enclosure.

- When you use an external HIM, you must place a ferrite core around the HIM cable. Use Fair-Rite Products Corp. part no. 0431167281 or equivalent.
- When you use 240V AC control voltage, you must place a ferrite core around the line/neutral supply wires at the control module. Use Fair-Rite Products Corp. part no. 0431164281 or equivalent.
- When you use 120V AC control on a solid-state D-frame unit, (361, 420, or 520 A), you must place a ferrite core around the line/neutral supply wires at the control module. Use Fair-Rite Products Corp. part no. 0431164281 or equivalent.
- When you use a solid-state B-frame unit, (90, 110, 140, or 180 A), you must install the 150-SMCAP module on the 3-phase line terminals (L1, L2, L3).
- When you use a 150-SM2 option module, you must place a ferrite core around any or all sensor wires, such as PTC or ground fault. Use Fair-Rite Products Corp. part no. 0431167281 or equivalent.

Power Wiring with External Bypass

You can use both the internal bypass and solid-state power structure versions of the SMC-50 controller with an external bypass contactor. [Figure 22](#) through [Figure 26](#) show typical wiring diagrams for line- and inside-the-delta-connected configurations.

All diagrams are valid for both solid-state and internal bypass power structures unless otherwise noted.

Line-connected Motors

Figure 22 - Line-connected Motor Wiring Diagram using Bul. 825 Converter Module and Cat. No. 150-SM2 Devices with Bypass Contactor

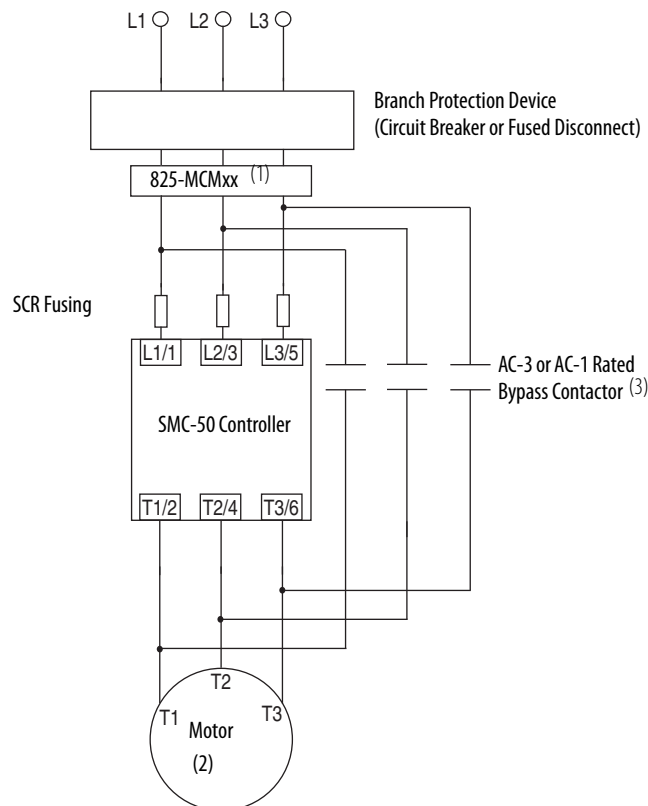

- (1) The 825-MCMxx provides current feedback to the SMC-50 controller when RUN in Bypass Operation. A Cat. No.150-SM2 is also required. For 30...180 A, use Cat. No. 825-MCM180; For 181...520 A, use Cat. No. 825-MCM20 and user-supplied CTs with 5 A secondary.
- (2) Due to current leakage through an SCR in the OFF state (controller stopped), some form of upstream line power isolation is recommended if maintenance is required on the motor. See the isolation contactor application information for details.
- (3) Bypass must be controlled by an auxiliary contact of the SMC-50 controller that is configured to external bypass.

Figure 23 - Line-connected Motor Wiring Diagram for Cat. No. 150-SC... or 150-SD... Devices with Bypass Contactor and Bypass Bus Kit (Solid-state Power Structures Only)

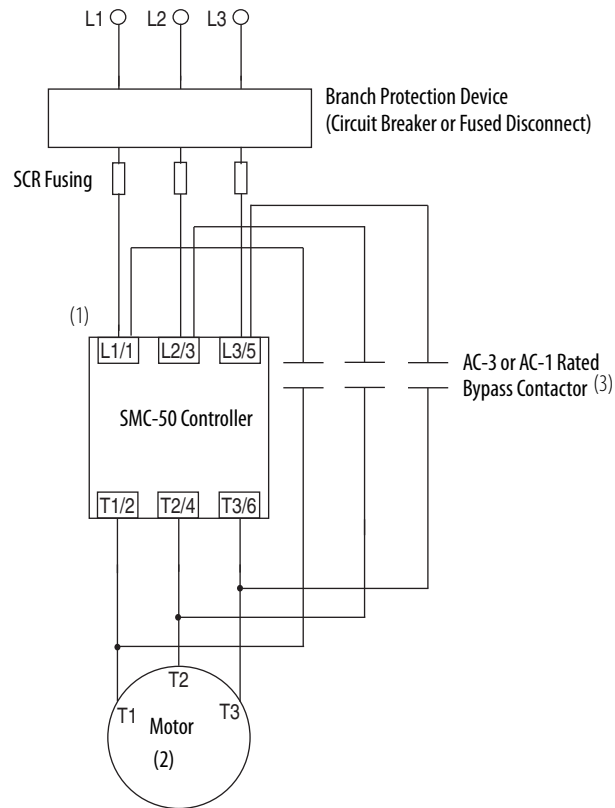

- (1) SMC-50 controller Bypass Bus Kit Cat. No. 150-SCBK or -SDBK is required.
- (2) Due to current leakage through an SCR in the OFF state (controller stopped), some form of upstream line power isolation is recommended if maintenance is required on the motor. See the isolation contactor application information for details.
- (3) Bypass must be controlled by an auxiliary contact of the SMC-50 controller that is configured to external bypass.

Figure 24 - Line-connected Motor Wiring Diagram with Bypass Contactor and External Overload

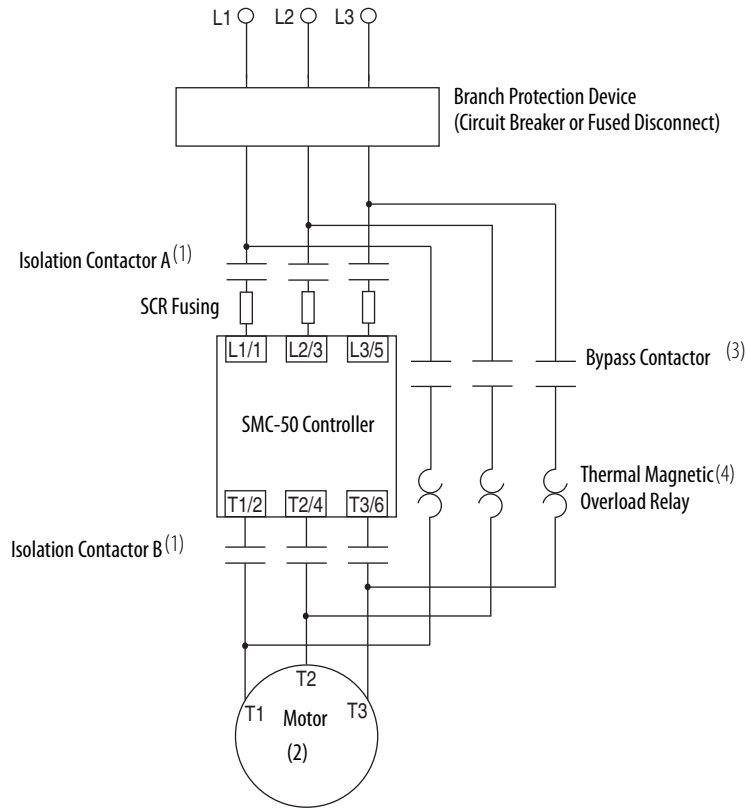

- (1) Isolation Contactors A and B are required if bypass is used for emergency START, STOP, and RUN operation.
 - (2) Due to current leakage through an SCR in the OFF state (controller stopped), some form of upstream line power isolation is recommended if maintenance is required on the motor. See the isolation contactor application information for details.
 - (3) Bypass must be controlled by an auxiliary contact of the SMC-50 controller that is configured to external bypass.
 - (4) Overload is required.
- NOTE: Bypass must be fully rated to motor Hp/kW and FLA.

Delta-connected Motors

Figure 25 - Delta-connected Motor Wiring Diagram using Bul. 825 Converter Module and Cat. No. 150-SM2 Devices with Bypass Contactor

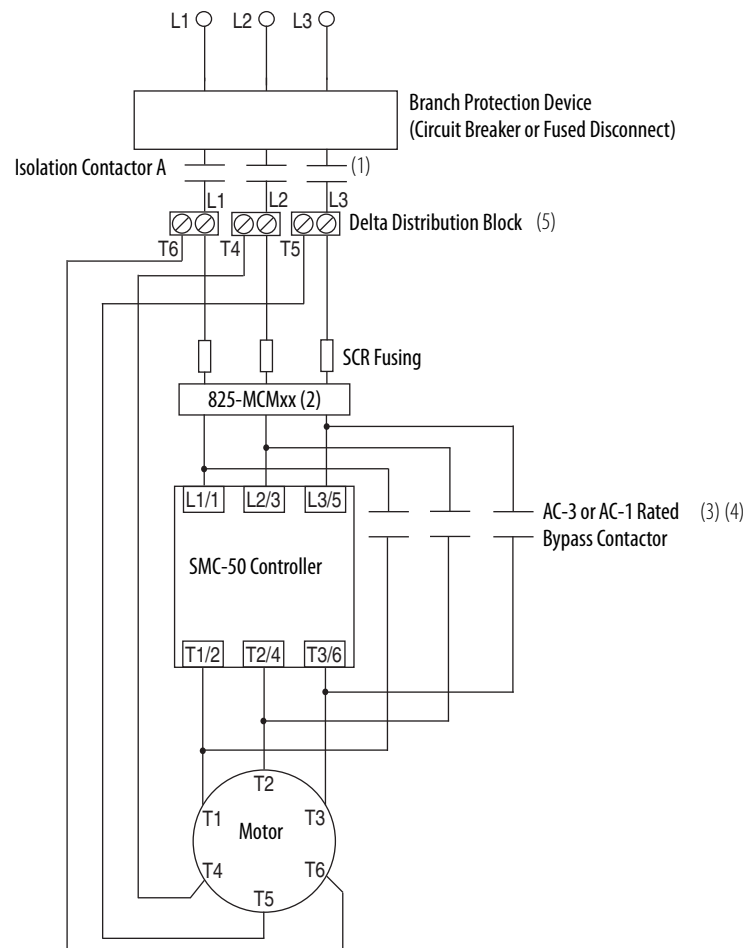

- (1) Isolation contactor required.
- (2) The 825-MCMxx provides current feedback to the SMC-50 controller when RUN in Bypass Operation. A Cat. No.150-SM2 is also required. For 30...180 A, use Cat. No. 825-MCM180; For 181...520 A, use Cat. No. 825-MCM20 and user-supplied CTs with 5 A secondary.
- (3) Configuration not acceptable for emergency RUN off bypass.
- (4) Bypass must be controlled by an auxiliary contact of the SMC-50 controller that is configured to external bypass.
- (5) Delta distribution block needed for solid-state power structures only.

Figure 26 - Delta-connected Motor Wiring Diagram for Cat. No. 150-SC... or 150-SD... Devices with Bypass Contactor and Bypass Bus Kit (Solid-state Power Structures Only)

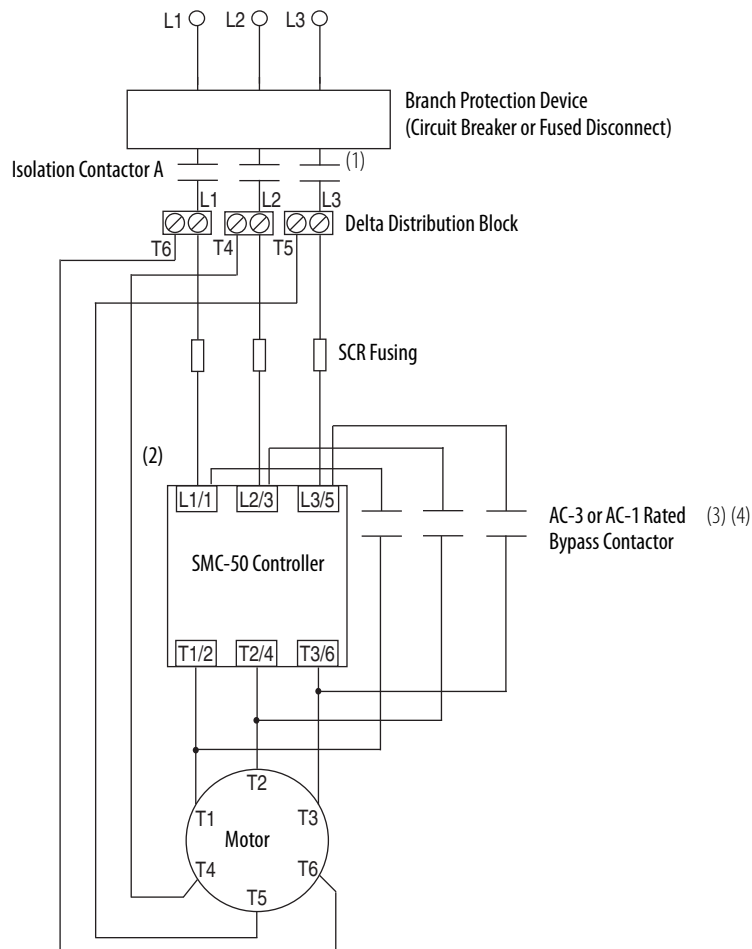

- (1) Isolation contactor required.
- (2) SMC bypass bus kit (Cat. No. 150-SCBK or -SDBK) is required.
- (3) Configuration not acceptable for emergency RUN off bypass. Note: controller FRN 3.001 or higher is required.
- (4) Bypass must be controlled by an auxiliary contact of the SMC-50 controller that is configured to external bypass.

Control Wiring

Standard Control Terminal Block

SMC-50 controllers come standard with two 24V DC digital on/off inputs and two relay outputs for auxiliary control functions. The standard digital I/O wiring terminal block is on the upper right portion of the SMC-50 controller. The terminal block is removable.

Control Wiring Specifications

The following table provides the specifications for all SMC-50 controller control wiring and option module terminal blocks. Each wiring terminal accepts a maximum of two wires.

Table 5 - Control Wiring Specifications

Wire Size	0.2...2.5 mm ² (#24...14 AWG)
Maximum Torque	0.8 N·m (7 lb·in.)
Maximum Wire Strip Length	7 mm (0.27 in.)
Screw Type	M3 Slotted



SHOCK HAZARD: To prevent the risk of electrical shock, disconnect all power sources from the controller and option module before you install or service it. Install the controller and option module in a suitable enclosure and keep it free of contaminants.

Figure 27 - Standard Control Terminal Block Identification

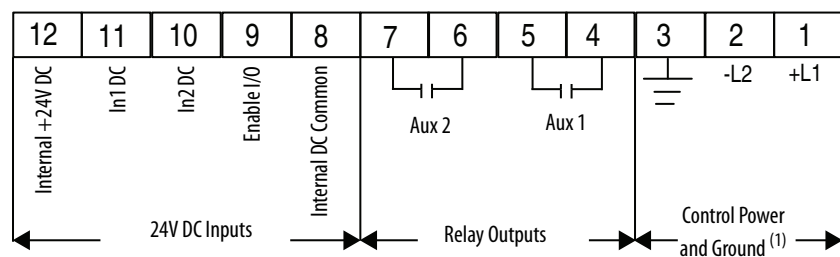

(1) See the controller nameplate to verify the control power ratings (120/240V AC or 24V DC).



ATTENTION: IN1 DC (terminal 11) and IN2 DC (terminal 10) are 24V DC inputs on controllers rated 120/240V AC and on controllers rated 24V DC. Voltages that exceed the specified input range may cause damage to the controller.

Terminal Number	Description
1 ⁽¹⁾ ⁽²⁾	Control Power +L1
2 ⁽¹⁾ ⁽²⁾	Control Power Common -L2
3	Ground — To connect to the system/control ground point.
4 ⁽¹⁾ ⁽³⁾	Auxiliary Relay Contact #1—rated 3 A @ 120V AC, 1.5 A @ 240V AC
5 ⁽¹⁾ ⁽³⁾	Auxiliary Relay Contact #1—rated 3 A @ 120V AC, 1.5 A @ 240V AC
6 ⁽¹⁾ ⁽³⁾	Auxiliary Relay Contact #2—rated 3 A @ 120V AC, 1.5 A @ 240V AC
7 ⁽¹⁾ ⁽³⁾	Auxiliary Relay Contact #2—rated 3 A @ 120V AC, 1.5 A @ 240V AC
8	DC Internal I/O Power, DC Common
9	Enable I/O
10 ⁽¹⁾ ⁽⁴⁾	Input #2 (24V DC) (range 15...30V DC)
11 ⁽¹⁾ ⁽⁴⁾	Input #1 (24V DC) (range 15...30V DC)
12	+24V DC Internal I/O Power

(1) RC snubbers are required when inductive loads are connected to terminal.

(2) See the controller nameplate to verify the control power ratings (120/240V AC or 24V DC)

(3) When set to external bypass mode, the auxiliary contact is used to control a properly sized external contactor and overload once the motor is at full speed.

(4) Do not connect any additional loads to this terminal. Parasitic loads may cause problems with operation.

Standard Controller Wiring Diagrams

Figure 28 through Figure 50 show typical wiring diagrams for the SMC-50 controller in various applications.

Figure 28 - For Standard 3-Wire Control—DC Inputs, No DPI Control

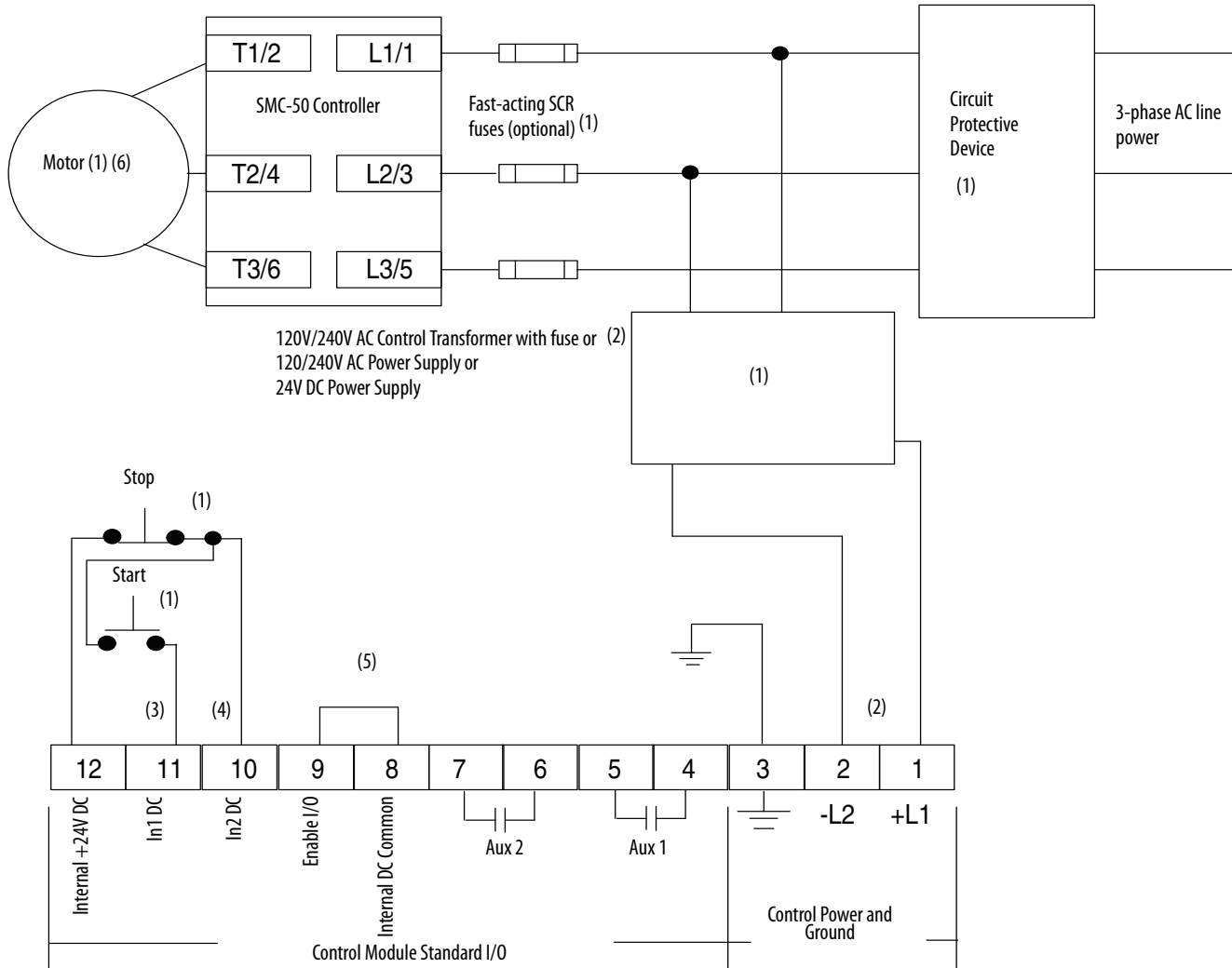

(1) Customer supplied.

(2) See the controller nameplate to verify control power input ratings (100...240V AC or 24V DC).

(3) Terminal 11 (In 1 DC) 24V DC input configured for START input using Parameter 56.

(4) Terminal 10 (In 2 DC) 24V DC input configured for COAST, STOP option, etc. using Parameter 57.

NOTE: The controller generates an I/O configuration fault if any input is configured for START or SLOW speed and no input is selected for COAST or STOP.

(5) A customer-supplied jumper is required to enable standard I/O operation.

(6) Due to current leakage through an SCR in the OFF state (controller stopped), some form of off-stream line power isolation is recommended if maintenance is required on the motor. See the Isolation Contactor Applications diagram for details.

NOTE: In addition to a small amount of leakage current flowing through an SCR in the off-state, failure of one or more solid-state power switching components allows uncontrolled current to flow to the winding(s) of the motor. This could potentially result in overheating or damage to the motor. To prevent potential personal injury or equipment damage, the installation of an isolation contactor or shunt trip-type circuit breaker capable of interrupting the motor's locked rotor current on the line side of the SMC-50 controller is recommended. Operation of the isolation device should be coordinated using one of the SMC-50 controller Aux contacts configured to NORMAL.

Figure 29 - For 2-Wire Control with Stopping Capability—DC Inputs, No DPI Control

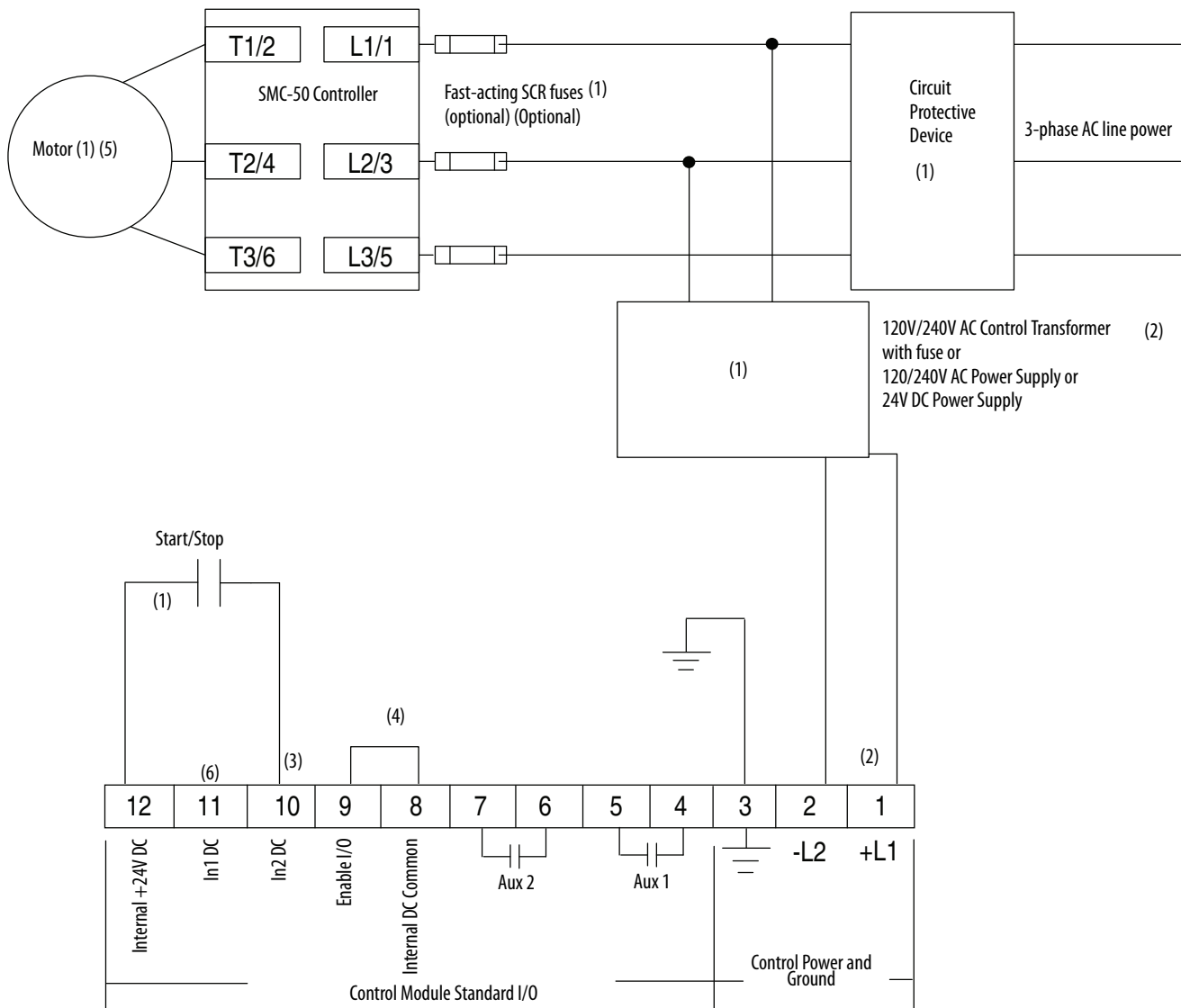

(1) Customer supplied.

(2) See the controller nameplate to verify control power input ratings (100...240V AC or 24V DC).

(3) Terminal 10 (In 2 DC) 24V DC N.O. input is configured for START/STOP or START/COAST using Parameter 57 (contact closed start initiated, contact open, stop initiated). When using START/STOP or START/COAST, a N.O. input contact **must** be used.

NOTE: The controller generates an I/O configuration fault if any input is configured for START or SLOW speed and no input is selected for COAST or STOP.

(4) A customer-supplied jumper is required to enable controller standard I/O operation.

(5) Due to current leakage through an SCR in the OFF state (controller stopped), some form of upstream line power isolation is recommended if maintenance is required on the motor. See the Isolation Contactor Applications diagram for details.

(6) Configure In1 (Input 1—Parameter 56) to "Disable".

NOTE: In addition to a small amount of leakage current flowing through an SCR in the off-state, failure of one or more solid-state power switching components allows uncontrolled current to flow to the winding(s) of the motor. This could potentially result in overheating or damage to the motor. To prevent potential personal injury or equipment damage, the installation of an isolation contactor or shunt trip-type circuit breaker capable of interrupting the motor's locked rotor current on the line side of the SMC-50 controller is recommended. Operation of the isolation device should be coordinated using one of the SMC-50 controller Aux contacts configured to NORMAL.

Figure 30 - For 2-Wire Control with Stopping Capability—AC Inputs, No DPI Control

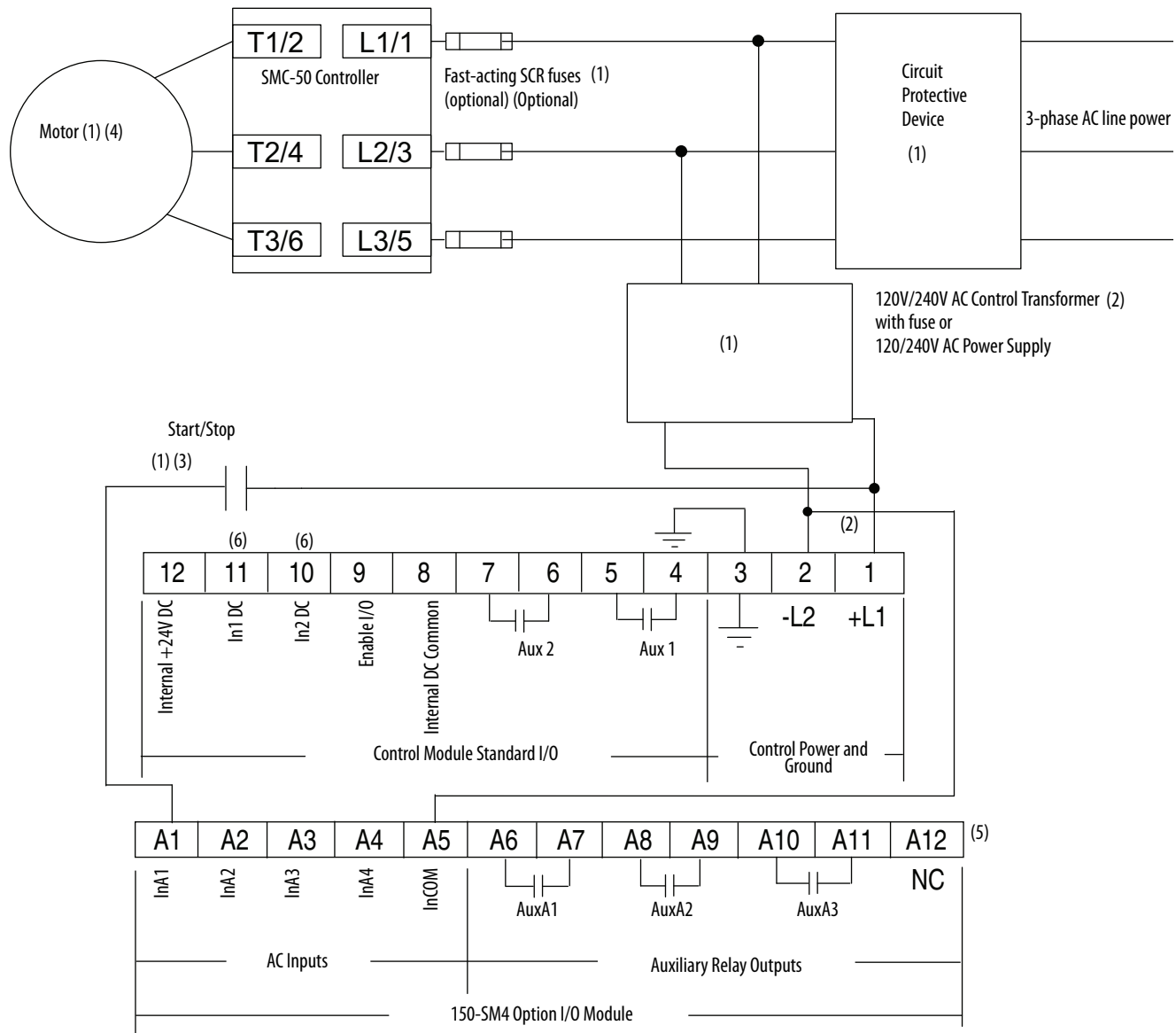

- (1) Customer supplied.
- (2) See the controller nameplate to verify control power input ratings (100...240V AC).
- (3) Terminal A1 (InA1) 100...240V AC N.O. input is configured for START/STOP or START/COAST using Parameter 7-2 (control module port number 7) (contact closed, start initiated, contact open, stop initiated). When using START/STOP or START/COAST, a N.O. input contact **must** be used.
- NOTE:** The controller generates an I/O configuration fault if any input is configured for START or SLOW speed and no input is selected for COAST or STOP.
- (4) Due to current leakage through an SCR in the OFF state (controller stopped), some form of upstream line power isolation is recommended if maintenance is required on the motor. See the Isolation Contactor Applications diagram for details.
- (5) The order of the terminal numbers for the option I/O module can be reversed depending on which expansion slot option I/O module is located in on the control module. However, the function associated with the terminal number remains the same.
- (6) Configure both In1 (Input 1—Parameter 56) and In2 (Input 2—Parameter 57) to "Disable".
- NOTE:** In addition to a small amount of leakage current flowing through an SCR in the off-state, failure of one or more solid-state power switching components allows uncontrolled current to flow to the winding(s) of the motor. This could potentially result in overheating or damage to the motor. To prevent potential personal injury or equipment damage, the installation of an isolation contactor or shunt trip-type circuit breaker capable of interrupting the motor's locked rotor current on the line side of the SMC-50 controller is recommended. Operation of the isolation device should be coordinated using one of the SMC-50 controller Aux contacts configured to NORMAL.

Figure 31 - For Dual Ramp Applications—AC and DC Inputs

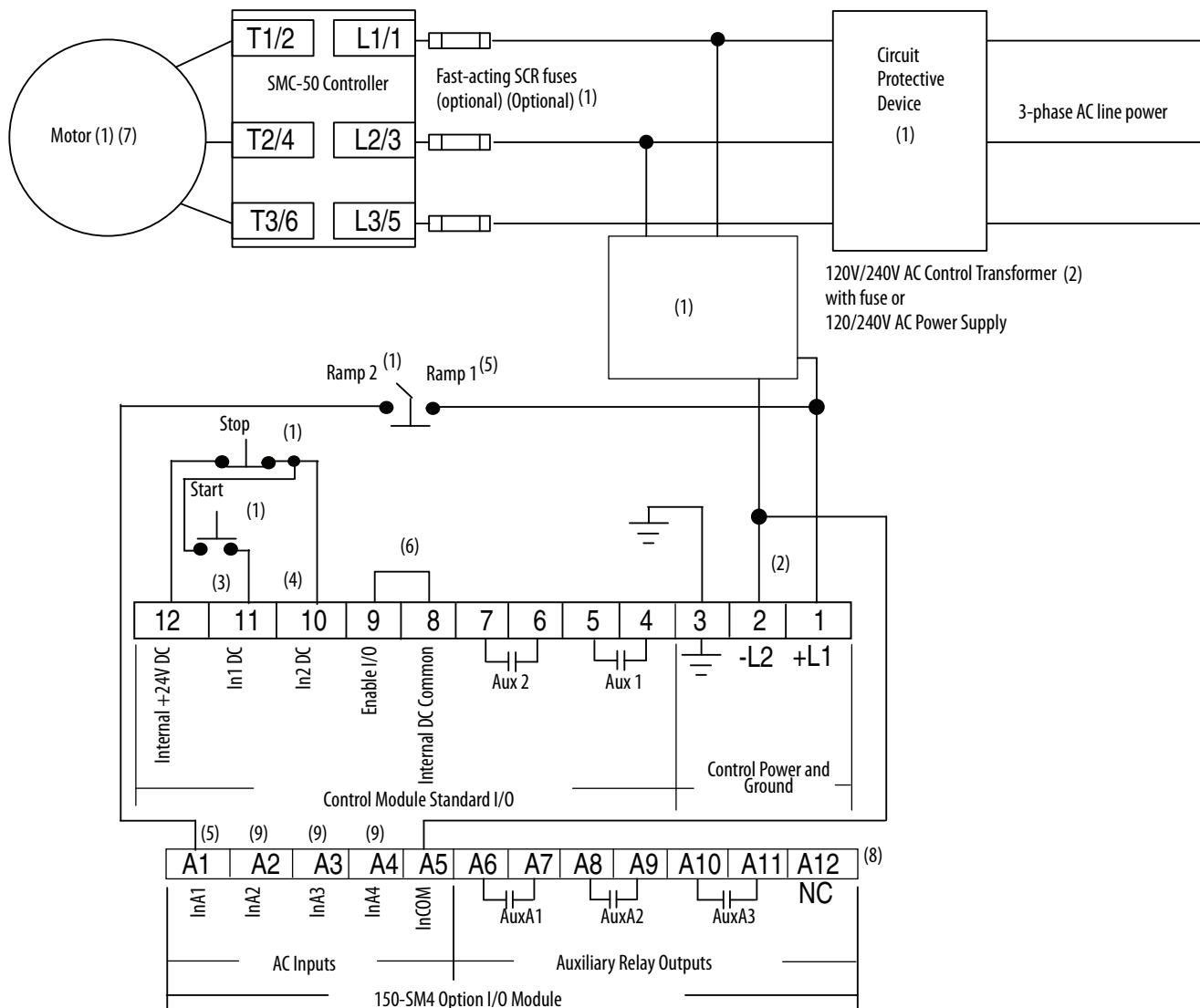

(1) Customer supplied.

(2) See the controller nameplate to verify control power input ratings (100...240V AC).

(3) Terminal 11 (In 1 DC) 24V DC input configured for START input using Parameter 56.

(4) Terminal 10 (In 2 DC) 24V DC input configured for COAST, STOP option, etc. using Parameter 57.

NOTE: The controller generates an I/O configuration fault if any input is configured for START or SLOW speed and no input is selected for COAST or STOP.

(5) Terminal A1 (INA1) 100...240V AC input is configured for Dual Ramp using Parameter 7-2 (control module port 7).

(6) A customer supplied jumper is required to enable controller I/O operation.

(7) Due to current leakage through an SCR in the OFF state (controller stopped), some form of off-stream line power isolation is recommended if maintenance is required on the motor. See the Isolation Contactor Applications diagram for details.

(8) The order of the terminal numbers for the option I/O module can be reversed depending on which expansion slot option I/O module is located in on the control module. However, the function associated with the terminal number remains the same.

(9) Ensure that InA2, InA3, and InA4 are configured to "Disable" [Default].

NOTE: In addition to a small amount of leakage current flowing through an SCR in the off-state, failure of one or more solid-state power switching components allows uncontrolled current to flow to the winding(s) of the motor. This could potentially result in overheating or damage to the motor. To prevent potential personal injury or equipment damage, the installation of an isolation contactor or shunt trip-type circuit breaker capable of interrupting the motor's locked rotor current on the line side of the SMC-50 controller is recommended. Operation of the isolation device should be coordinated using one of the SMC-50 controller Aux contacts configured to NORMAL.

Figure 32 - For Dual Ramp—AC Inputs

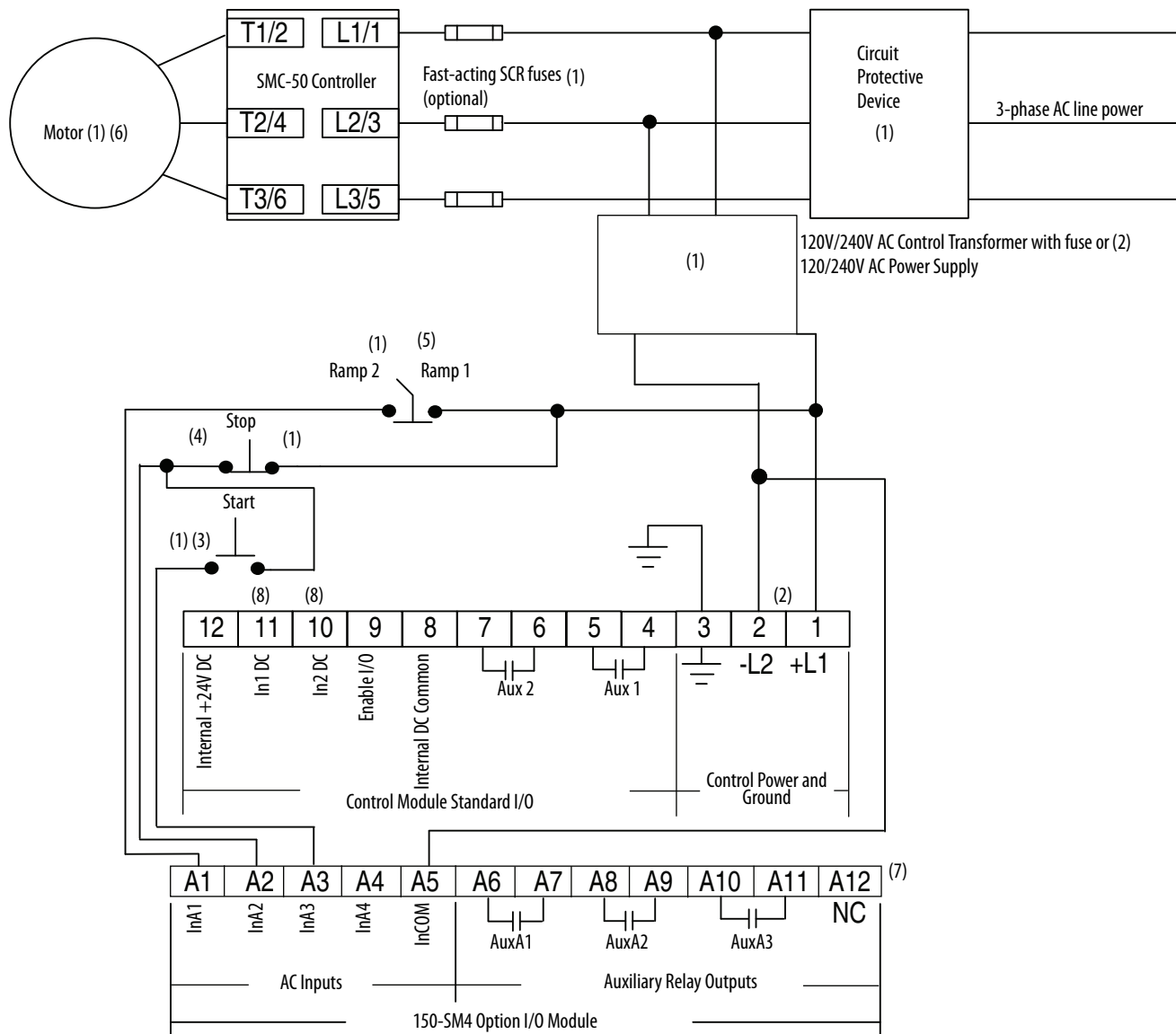

- (1) Customer supplied.
- (2) See the controller nameplate to verify control power input ratings (100...240V AC).
- (3) Terminal A3 (InA3) 100...240V AC input configured for START input using Parameter 7-4 (control module port 7).
- (4) Terminal A2 (InA2) 100...240V AC input configured for COAST, STOP option, etc. using Parameter 7-3 (control module port 7).
- NOTE:** The controller generates an I/O configuration fault if any input is configured for START or SLOW speed and no input is selected for COAST or STOP.
- (5) Terminal A1 (InA1) 100...240V AC input is configured for Dual Ramp using Parameter 7-2 (control module port 7).
- (6) Due to current leakage through an SCR in the OFF state (controller stopped), some form of off-stream line power isolation is recommended if maintenance is required on the motor. See the Isolation Contactor Applications diagram for details.
- (7) The order of the terminal numbers for the option I/O module can be reversed depending on which expansion slot the option I/O module is located on the control in the control module. However, the function associated with the terminal number remains the same.
- (8) Configure both In1 (Input 1—Parameter 56) and In2 (Input 2—Parameter 57) to "Disable".
- NOTE:** In addition to a small amount of leakage current flowing through an SCR in the off-state, failure of one or more solid-state power switching components allows uncontrolled current to flow to the winding(s) of the motor. This could potentially result in overheating or damage to the motor. To prevent potential personal injury or equipment damage, the installation of an isolation contactor or shunt trip-type circuit breaker capable of interrupting the motor's locked rotor current on the line side of the SMC-50 controller is recommended. Operation of the isolation device should be coordinated using one of the SMC-50 controller Aux contacts configured to NORMAL.

Figure 33 - For Start/Stop Control via HIM or Communications

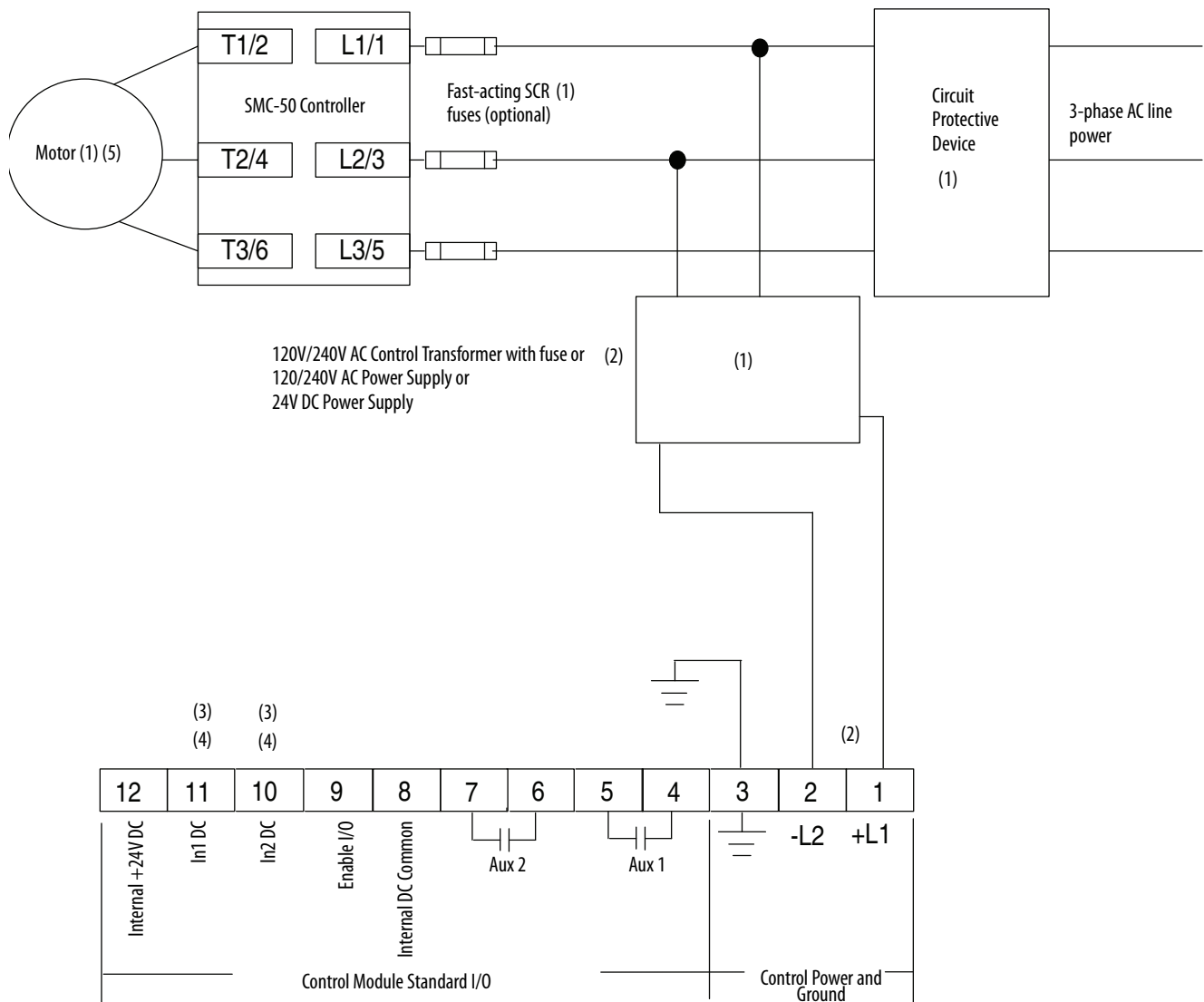

- (1) Customer supplied.
- (2) See the controller nameplate to verify control power input ratings (100...240V AC or 24V DC).
- (3) Configure both In1 (Input 1—Parameter 56) and In2 (Input 2—Parameter 57) to "Disable".
- NOTE:** If terminal 10 and 11 are required for a non Stop/Start function (e.g. slow speed), see Parameter 56 and Parameter 57 Communication Control word bits 0-5 for options.
- (4) For DPI operation, if the start/stop operation is done via communications (DPI port, 20-COMM module, or HIM) the appropriate bit (0...4) in the Logic Mask, Parameter 148, must be set. See [Chapter 9](#) for additional details.
- (5) Due to current leakage through an SCR in the OFF state (controller stopped), some form of off-stream line power isolation is recommended if maintenance is required on the motor. See the Isolation Contactor Applications diagram for details.
- NOTE:** In addition to a small amount of leakage current flowing through an SCR in the off-state, failure of one or more solid-state power switching components allows uncontrolled current to flow to the winding(s) of the motor. This could potentially result in overheating or damage to the motor. To prevent potential personal injury or equipment damage, the installation of an isolation contactor or shunt trip-type circuit breaker capable of interrupting the motor's locked rotor current on the line side of the SMC-50 controller is recommended. Operation of the isolation device should be coordinated using one of the SMC-50 controller Aux contacts configured to NORMAL.

Figure 34 - For Retrofit Applications— AC Inputs, No DPI Control

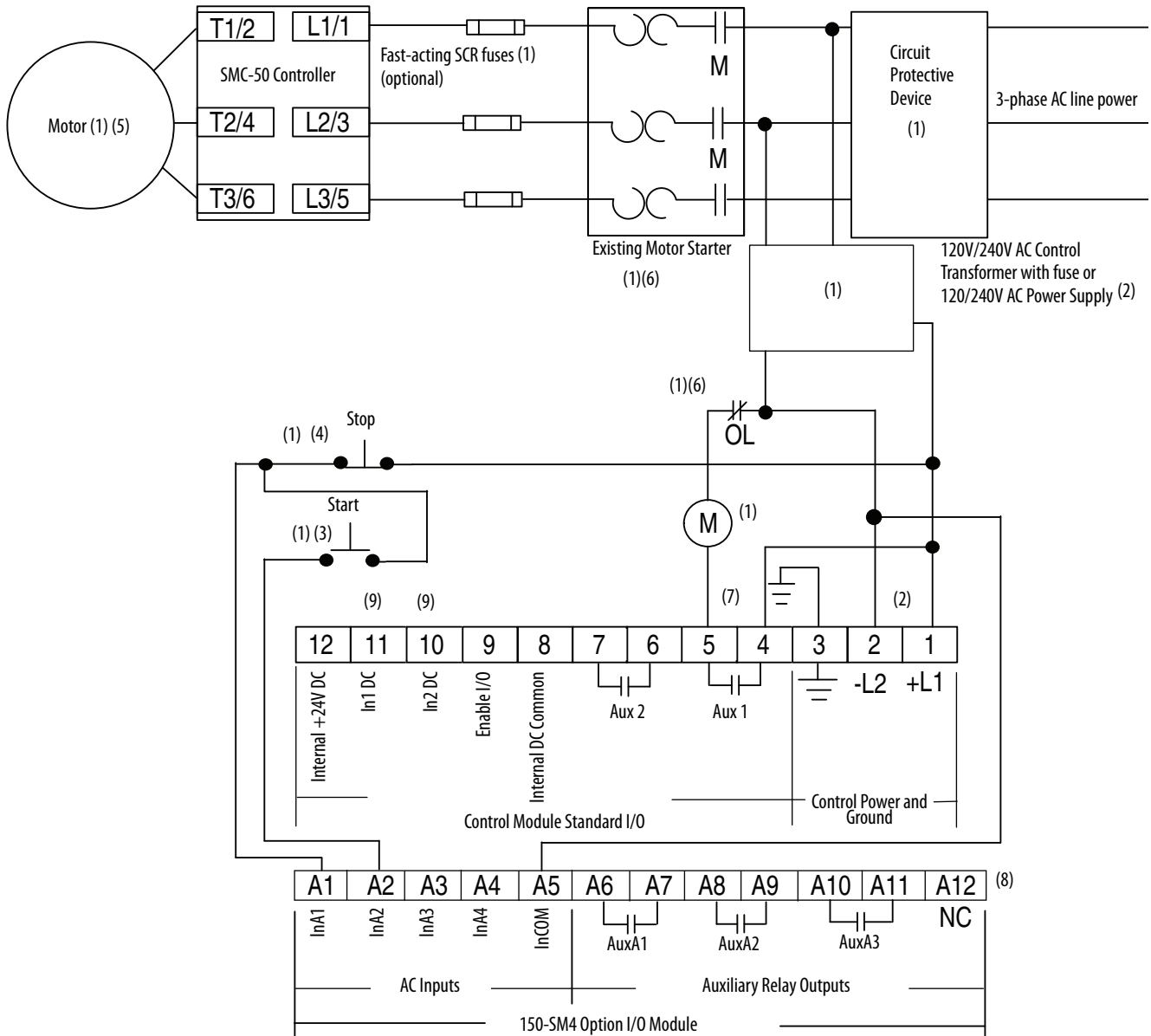

- (1) Customer supplied.
- (2) See the controller nameplate to verify control power input ratings (100...240V AC).
- (3) Terminal A2 (InA2) 100...240V AC input configured for START input using Parameter 7-3 (control module port 7).
- (4) Terminal A1 (InA1) 100...240V AC input configured for Coast, Stop Option, etc, using Parameter 7-2 (control module port 7).
- NOTE:** The controller generates an I/O configuration fault if any input is configured for START or SLOW speed and no input is configured for COAST or STOP.
- (5) Due to current leakage through an SCR in the OFF state (controller stopped), some form of upstream line power isolation is recommended if maintenance is required on the motor. In this example, the Existing Motor Starter fulfills that requirement.
- (6) Due to existing motor starter overload protection, the overload protection should be disabled in the SMC-50 controller.
- (7) Set Aux 1 to NORMAL using Parameter 172. NORMAL = Aux 1 contact closes to energize the M coil with the START push button and will open to de-energize it when the stop maneuver, initiated by the stop push button, is complete.
- (8) The order of the terminal numbers for the option I/O module can be reversed depending on which expansion slot it is located in on the control module. However, the function associated with the terminal number remains the same.
- (9) Configure both In1 (Input 1—Parameter 56) and In2 (Input 2—Parameter 57) to "Disable".

Figure 35 - For Retrofit Applications – DC Inputs, No DPI Control

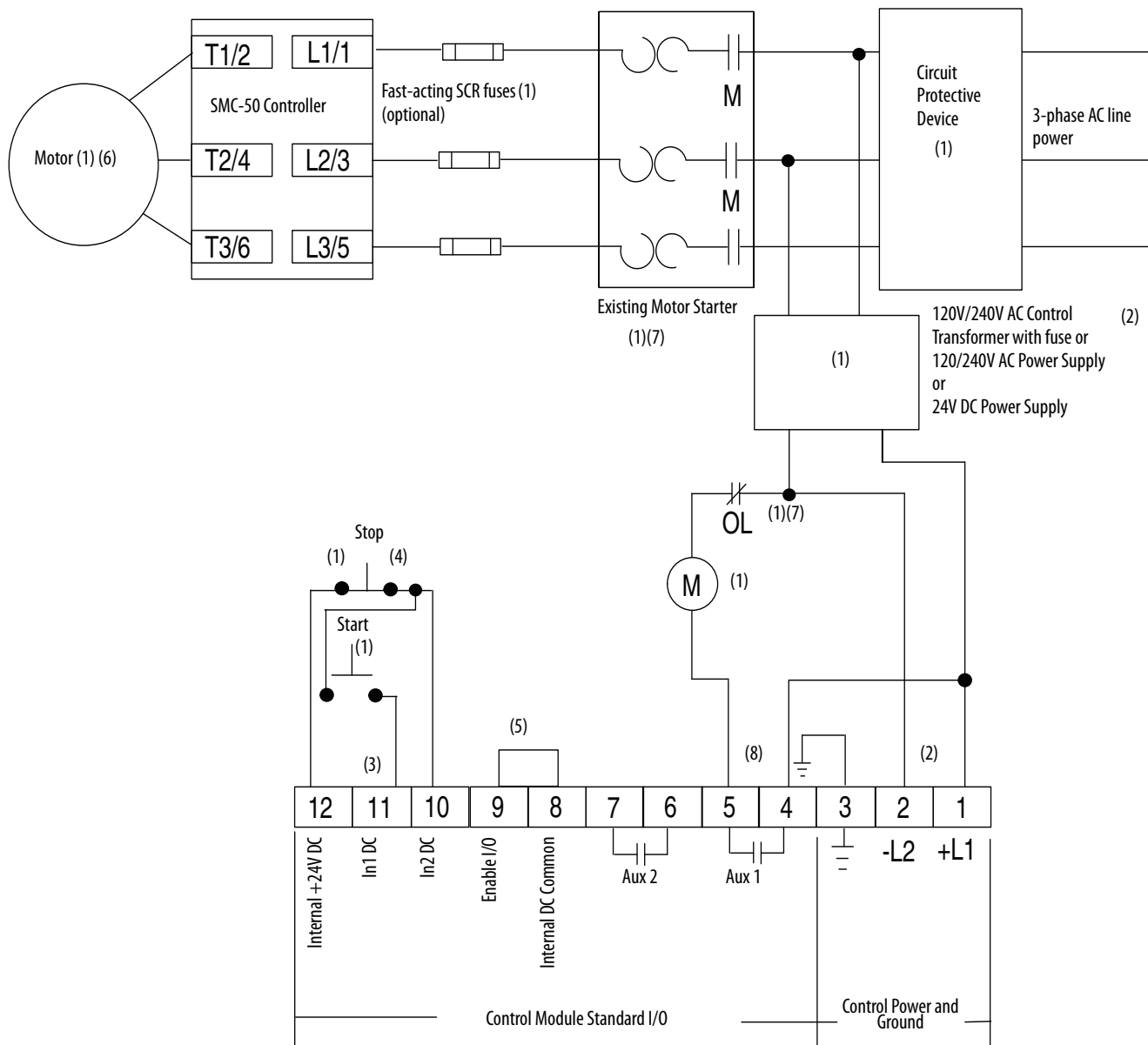

(1) Customer supplied.

(2) See the controller nameplate to verify control power input ratings (100...240V AC or 24V DC).

(3) Terminal 11 (In1 DC) 24V DC input is configured for START input using Parameter 56.

(4) Terminal 10 (In2 DC) 24V DC input configured for COAST, STOP OPTION, etc. using Parameter 57.

NOTE: The controller generates an I/O configuration fault if any input is configured for START or SLOW speed and no input is configured for COAST or STOP.

(5) A customer-supplied jumper is required to enable the controller I/O operation.

(6) Due to current leakage through an SCR in the OFF state (controller stopped), some form of upstream line power isolation is recommended if maintenance is required on the motor. In this example, the existing Motor Starter fulfills that requirement.

(7) Due to existing motor starter overload protection, the overload protection should be disabled in the SMC-50 controller.

(8) Set Aux 1 to NORMAL using Parameter 172. NORMAL = Aux 1 contact closes to energize the M coil with the START push button and will open to de-energize it when the stop maneuver, initiated by the stop push button, is complete.

Figure 36 - For Isolation Contactor Applications—DC Inputs

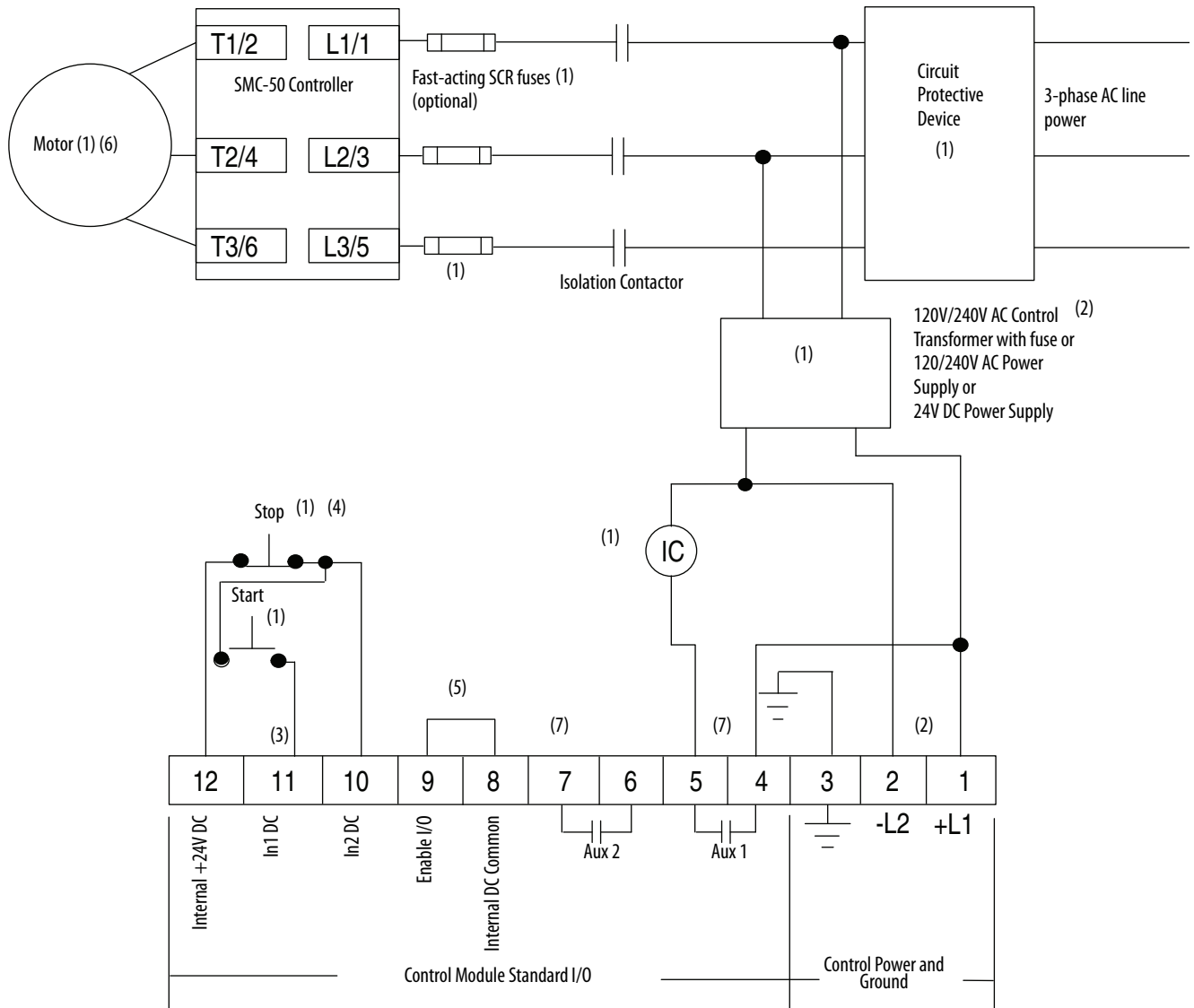

(1) Customer supplied.

(2) See the controller nameplate to verify control power input ratings (100...240V AC or 24V DC).

(3) Terminal 11 (In1 DC) 24V DC input is configured for START input using Parameter 56.

(4) Terminal 10 (In2 DC) 24V DC input configured for COAST, STOP OPTION, etc. using Parameter 57.

NOTE: The controller generates an I/O configuration fault if any input is configured for START or SLOW speed and no input is configured for COAST or STOP.

(5) A customer-supplied jumper is required to enable the controller I/O operation.

(6) Due to current leakage through an SCR in the OFF state (controller stopped), some form of upstream line power isolation (for example, the Isolation Contactor used in this diagram) is recommended if maintenance is required on the motor.

(7) Configure Aux 1 to NORMAL using Parameter 172. NORMAL = Aux 1 contact closes to energize the IC coil with the START push button and will open to de-energize it when the stop maneuver, initiated by the stop push button, is complete.

NOTE: In addition to a small amount of leakage current flowing through an SCR in the off-state, failure of one or more solid-state power switching components allows uncontrolled current to flow to the winding(s) of the motor. This could potentially result in overheating or damage to the motor. To prevent potential personal injury or equipment damage, the installation of an isolation contactor (as shown in this diagram) or shunt trip-type circuit breaker capable of interrupting the motor's locked rotor current on the line side of the SMC-50 controller is recommended. Operation of the isolation device should be coordinated using one of the SMC-50 controller Aux contacts configured to NORMAL.

Figure 37 - For Isolation Contactor Applications—AC Inputs

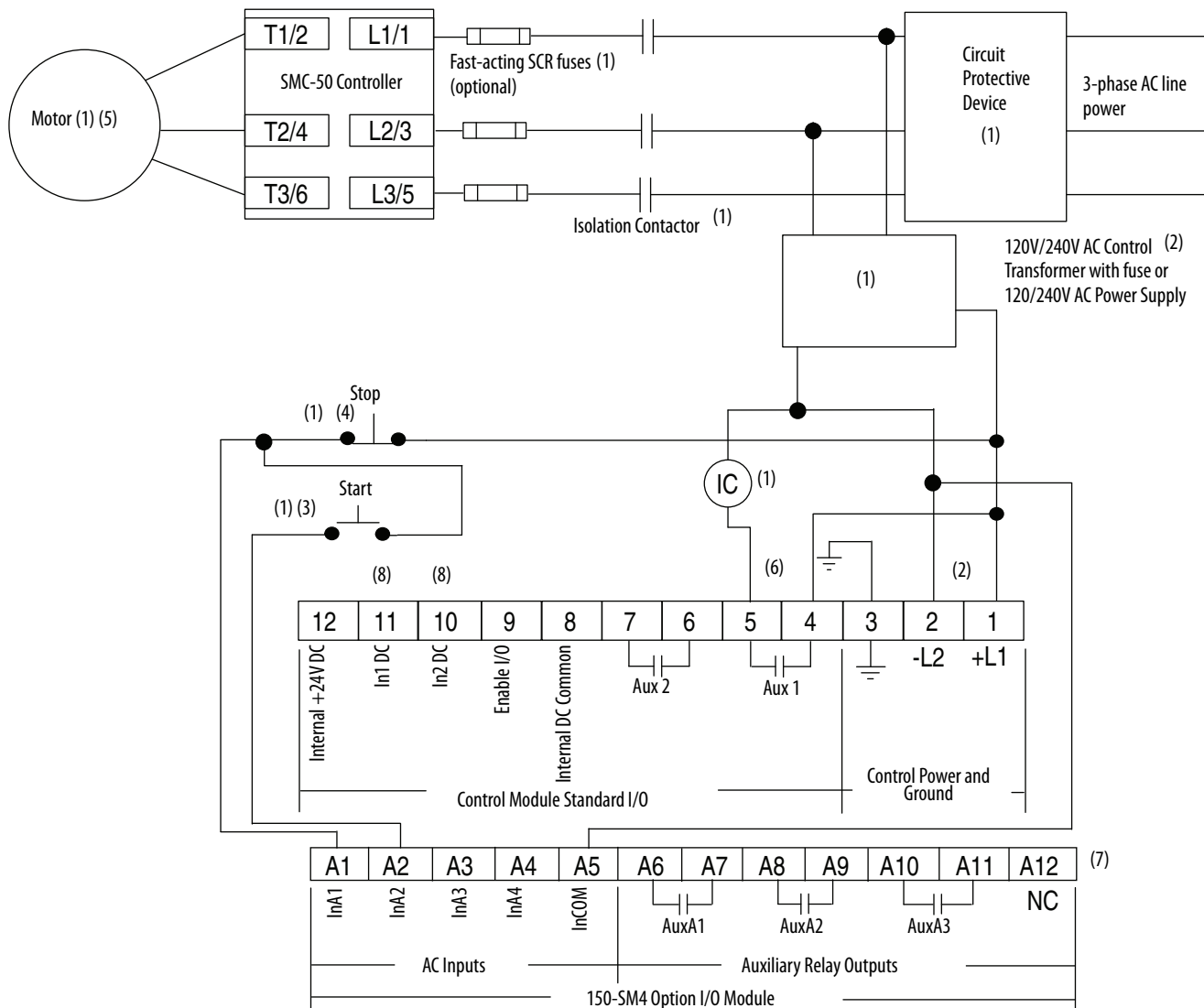

(1) Customer supplied.

(2) See the controller nameplate to verify control power input ratings (100...240V AC).

(3) Terminal A2 (InA2) 100...240V AC input is configured for START input using Parameter 7-3 (control module port 7).

(4) Terminal A1 (InA1) 100...240V AC input configured for COAST, STOP OPTION, etc. using Parameter 7-2 (control module port 7).

NOTE: The controller generates an I/O configuration fault if any input is configured for START or SLOW speed and no input is configured for COAST or STOP.

(5) Due to current leakage through an SCR in the OFF state (controller stopped), some form of upstream line power isolation (for example, the isolation contactor used in this diagram) is recommended if maintenance is required on the motor.

(6) Configure Aux 1 to NORMAL using Parameter 172. NORMAL = Aux 1 contact closes to energize the IC coil with the START push button and will open to de-energize it when the stop maneuver, initiated by the stop push button, is complete.

(7) The order of the terminal numbers for the option I/O module can be reversed depending on which expansion slot it is located in on the control module. However, the function associated with the terminal number remains the same.

NOTE: In addition to a small amount of leakage current flowing through an SCR in the off-state, failure of one or more solid-state power switching components allows uncontrolled current to flow to the winding(s) of the motor. This could potentially result in overheating or damage to the motor. To prevent potential personal injury or equipment damage, the installation of an isolation contactor (as shown in this diagram) or shunt trip-type circuit breaker capable of interrupting the motor's locked rotor current on the line side of the SMC-50 controller is recommended. Operation of the isolation device should be coordinated using one of the SMC-50 controller Aux contacts configured to NORMAL.

(8) Configure both In1 (Input 1—Parameter 56) and In2 (Input 2—Parameter 57) to "Disable".

Figure 38 - For Shunt Trip Applications—DC Inputs

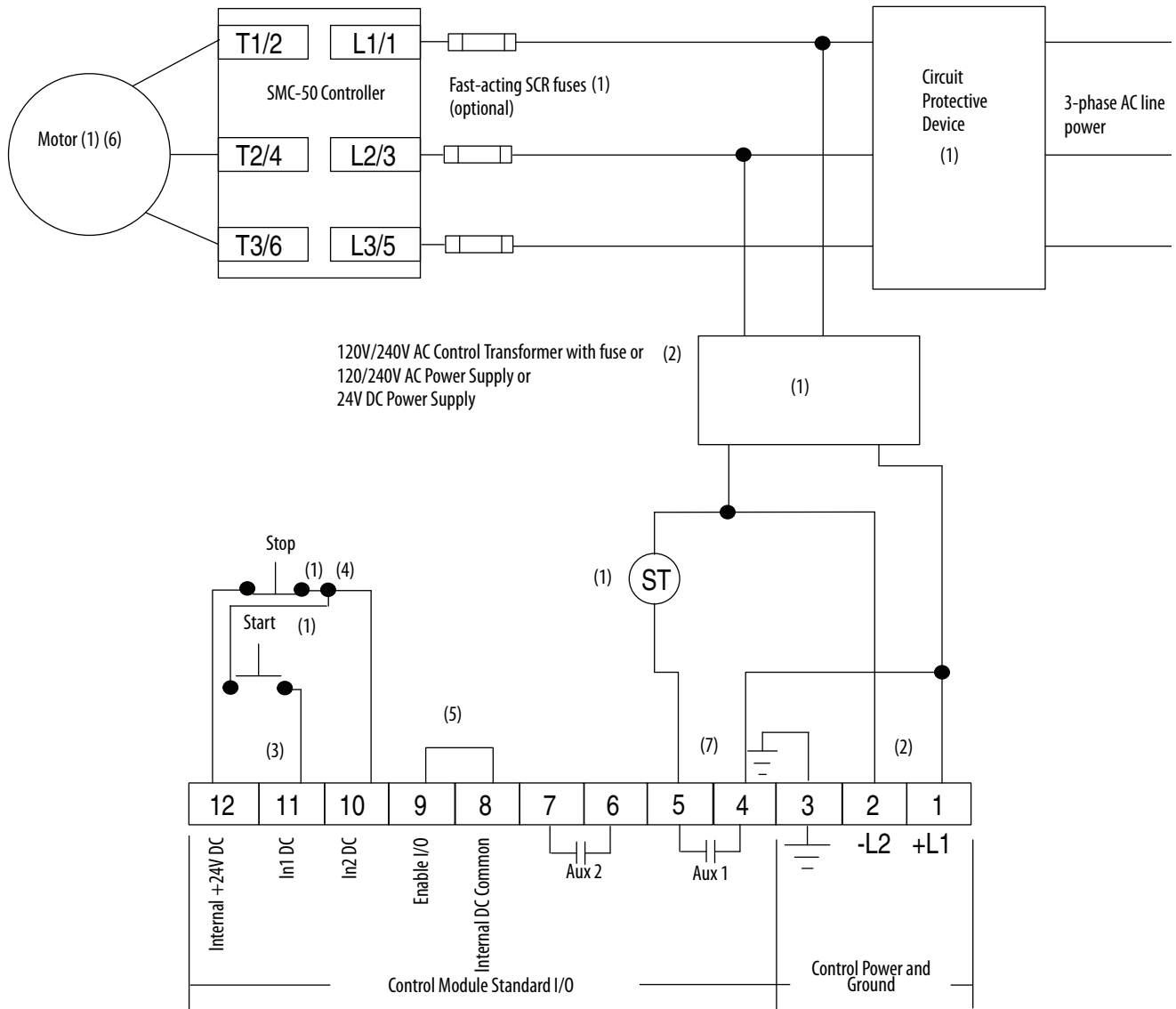

- (1) Customer supplied.
 - (2) See the controller nameplate to verify control power input ratings (100...240V AC or 24V DC).
 - (3) Terminal 11 (In1 DC) 24V DC input is configured for START input using Parameter 56.
 - (4) Terminal 10 (In2 DC) 24V DC input configured for COAST, STOP OPTION, etc. using Parameter 57.
- NOTE:** The controller generates an I/O configuration fault if any input is configured for START or SLOW speed and no input is configured for COAST or STOP.
- (5) A customer-supplied jumper is required to enable the controller I/O operation.
 - (6) Due to current leakage through an SCR in the OFF state (controller stopped), some form of upstream line power isolation is recommended if maintenance is required on the motor. See the Isolation Contactor Application for details.
 - (7) Configure Aux 1 to FAULT using Parameter 172. During a controller fault condition, the Aux 1 contact closes to energize the Shunt Trip (ST) coil.
- NOTE:** In addition to a small amount of leakage current flowing through an SCR in the off-state, failure of one or more solid-state power switching components allows uncontrolled current to flow to the winding(s) of the motor. This could potentially result in overheating or damage to the motor. To prevent potential personal injury or equipment damage, the installation of an isolation contactor or shunt trip-type circuit breaker capable of interrupting the motor's locked rotor current on the line side of the SMC-50 controller is recommended. Operation of the isolation device should be coordinated using one of the SMC-50 controller Aux contacts configured to NORMAL.

Figure 39 - For Shunt Trip Applications—AC Inputs

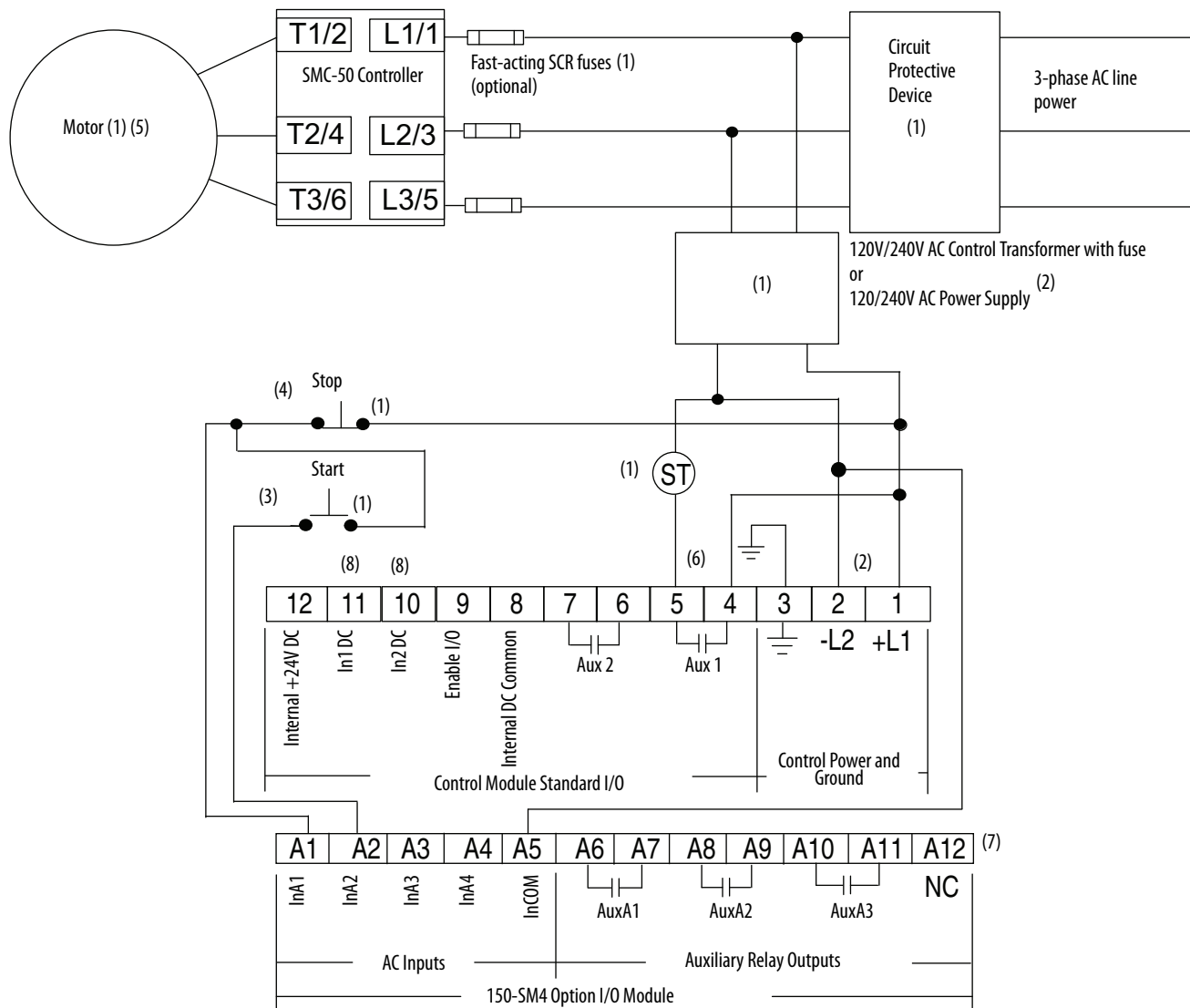

- (1) Customer supplied.
 - (2) See the controller nameplate to verify control power input ratings (100...240V AC).
 - (3) Terminal A2 (InA2) 100...240V AC input is configured for START input using Parameter 7-3 (control module port 7).
 - (4) Terminal A1 (InA1) 100...240V AC input configured for COAST, STOP OPTION, etc. using Parameter 7-2 (control module port 7).
- NOTE:** The controller generates an I/O configuration fault if any input is configured for START or SLOW speed and no input is configured for COAST or STOP.
- (5) Due to current leakage through an SCR in the OFF state (controller stopped), some form of upstream line power isolation is recommended if maintenance is required on the motor. See the Isolation Contactor Application for details.
 - (6) Configure Aux 1 to FAULT using Parameter 172. During a controlled fault condition the Aux 1 contact closes to energize the Shunt Trip (ST) coil.
 - (7) The order of the terminal numbers for the option I/O module can be reversed depending on which expansion slot it is located in on the control module. However, the function associated with the terminal number remains the same.
- NOTE:** In addition to a small amount of leakage current flowing through an SCR in the off-state, failure of one or more solid-state power switching components allows uncontrolled current to flow to the winding(s) of the motor. This could potentially result in overheating or damage to the motor. To prevent potential personal injury or equipment damage, the installation of an isolation contactor or shunt trip-type circuit breaker capable of interrupting the motor's locked rotor current on the line side of the SMC-50 controller is recommended. Operation of the isolation device should be coordinated using one of the SMC-50 controller Aux contacts configured to NORMAL.
- (8) Configure both In1 (Input 1—Parameter 56) and In2 (Input 2—Parameter 57) to "Disable".

Figure 40 - For Single-speed Reversing Applications—DC Control

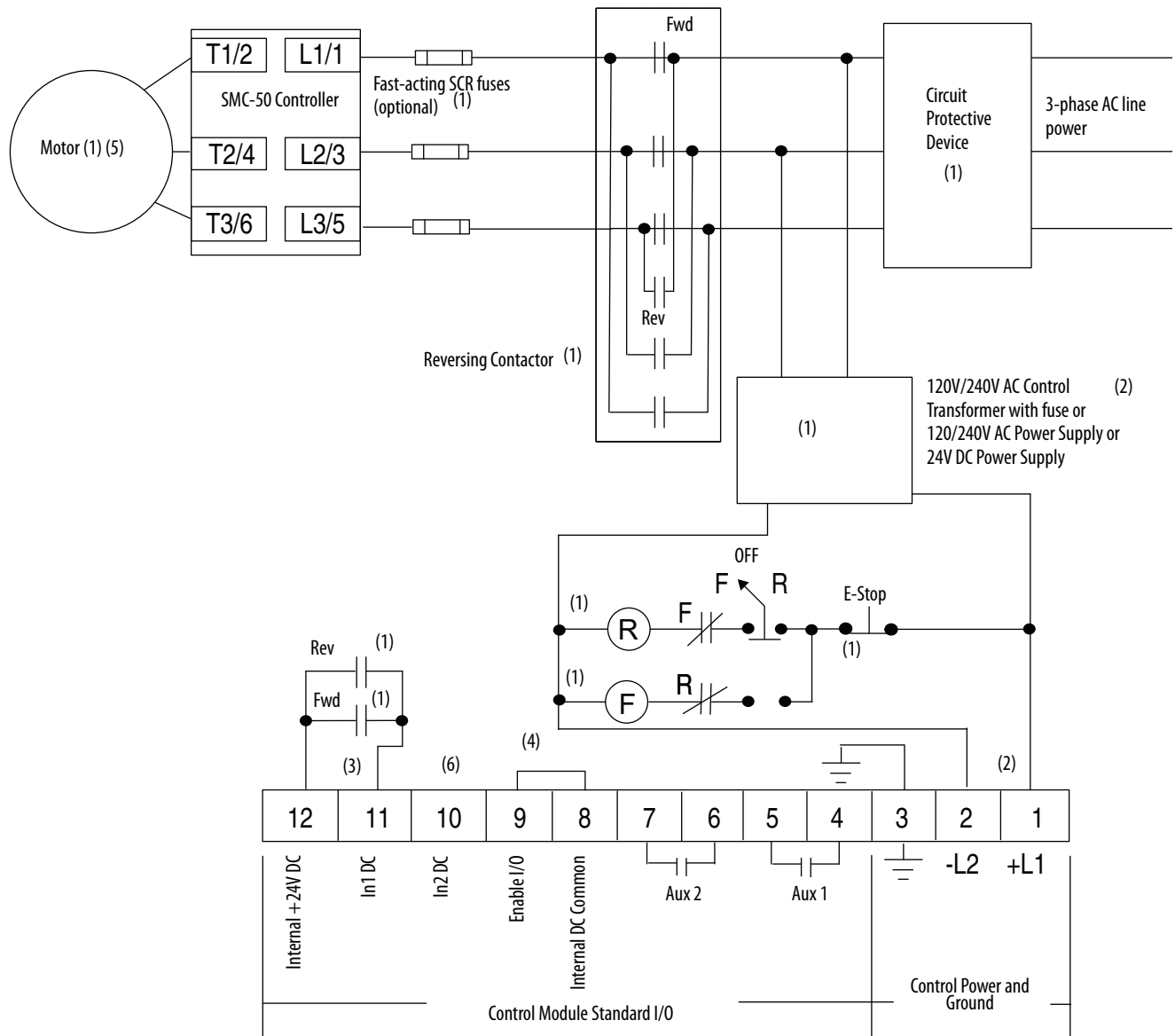

(1) Customer supplied.

(2) See the controller nameplate to verify control power input ratings (100...240V AC or 24V DC).

(3) Terminal 11 (In1 DC) 24V DC input is configured for START/COAST using Parameter 56.

NOTE: The controller generates an I/O configuration fault if any input is configured for START or SLOW speed and no input is configured for COAST or STOP.

(4) A customer-supplied jumper is required to enable the controller I/O operation.

(5) Due to current leakage through an SCR in the OFF state (controller stopped), some form of upstream line power isolation is recommended if maintenance is required on the motor. In this example, the reversing contactor provides isolation.

(6) Configure In2DC (Input 2 - Parameter 57) to "Disable".

NOTE: The SMC-50 controller minimum transition time for reversing is 0.5 s. The SMC-50 controller phase reversal must be disabled in reversing applications.

Figure 41 - For Two-Speed Applications—DC Control

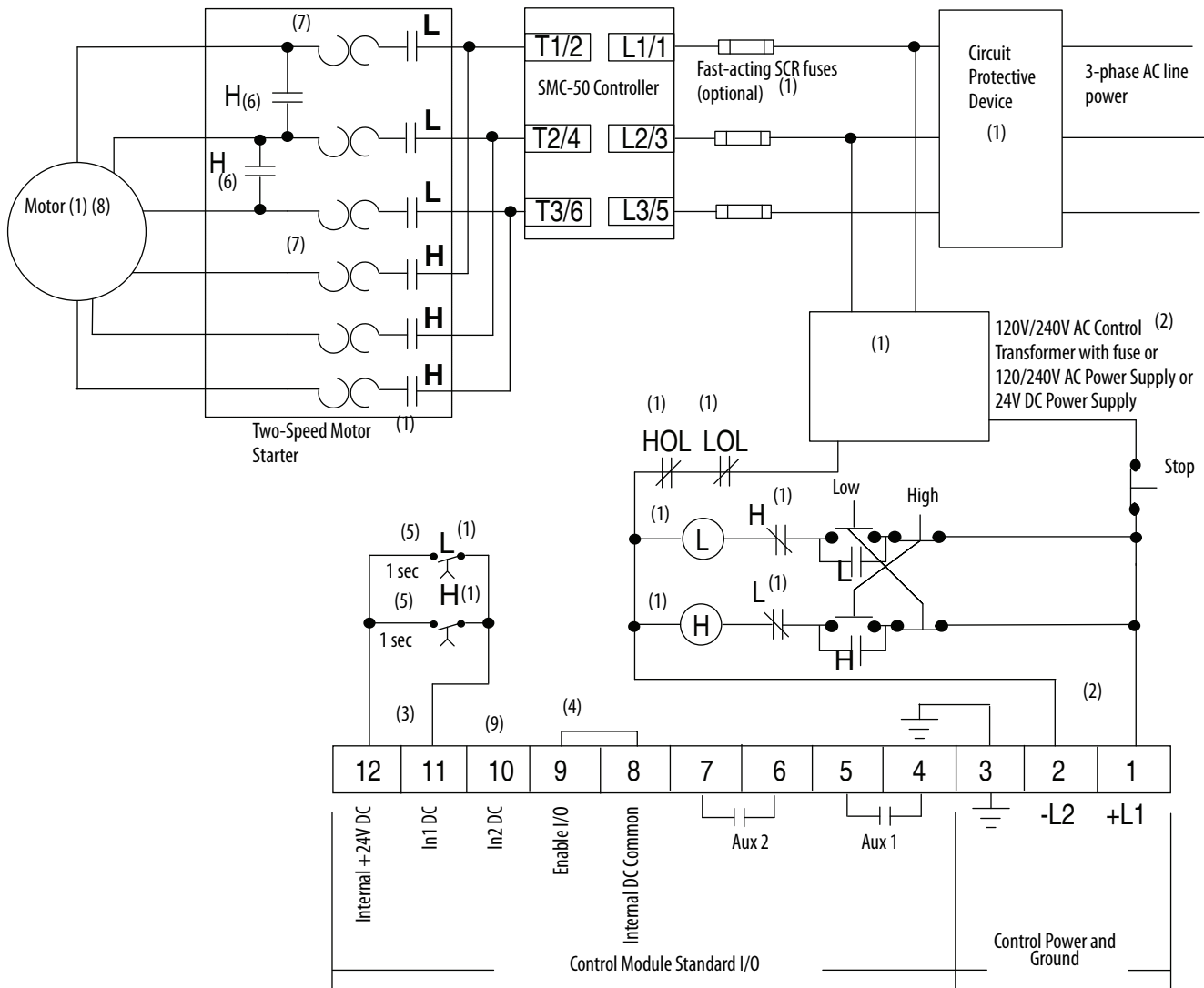

(1) Customer supplied.

(2) See the controller nameplate to verify control power input ratings (100...240V AC or 24V DC).

(3) Terminal 11 (In1 DC) 24V DC input is configured for START/COAST using Parameter 56.

NOTE: The controller generates an I/O configuration fault if any input is configured for START or SLOW speed and no input is configured for COAST or STOP.

(4) A customer-supplied jumper is required to enable the controller I/O operation.

(5) Customer-supplied timers with hard contact are required to accept DC power.

(6) Two-speed consequent pole operations.

(7) The SMC-50 controller overload must be disabled.

(8) Due to current leakage through an SCR in the OFF state (controller stopped), some form of upstream line power isolation is recommended if maintenance is required on the motor. See the Isolation Contactor Application for details.

NOTE: In addition to a small amount of leakage current flowing through an SCR in the off-state, failure of one or more solid-state power switching components allows uncontrolled current to flow to the winding(s) of the motor. This could potentially result in overheating or damage to the motor. To prevent potential personal injury or equipment damage, the installation of an isolation contactor or shunt trip-type circuit breaker capable of interrupting the motor's locked rotor current on the line side of the SMC-50 controller is recommended. Operation of the isolation device should be coordinated using one of the SMC-50 controller Aux contacts configured to NORMAL.

(9) Configure In2DC (Input 2 - Parameter 57) to "Disable".

Figure 42 - For SMC Start, Run, On Bypass—DC Inputs

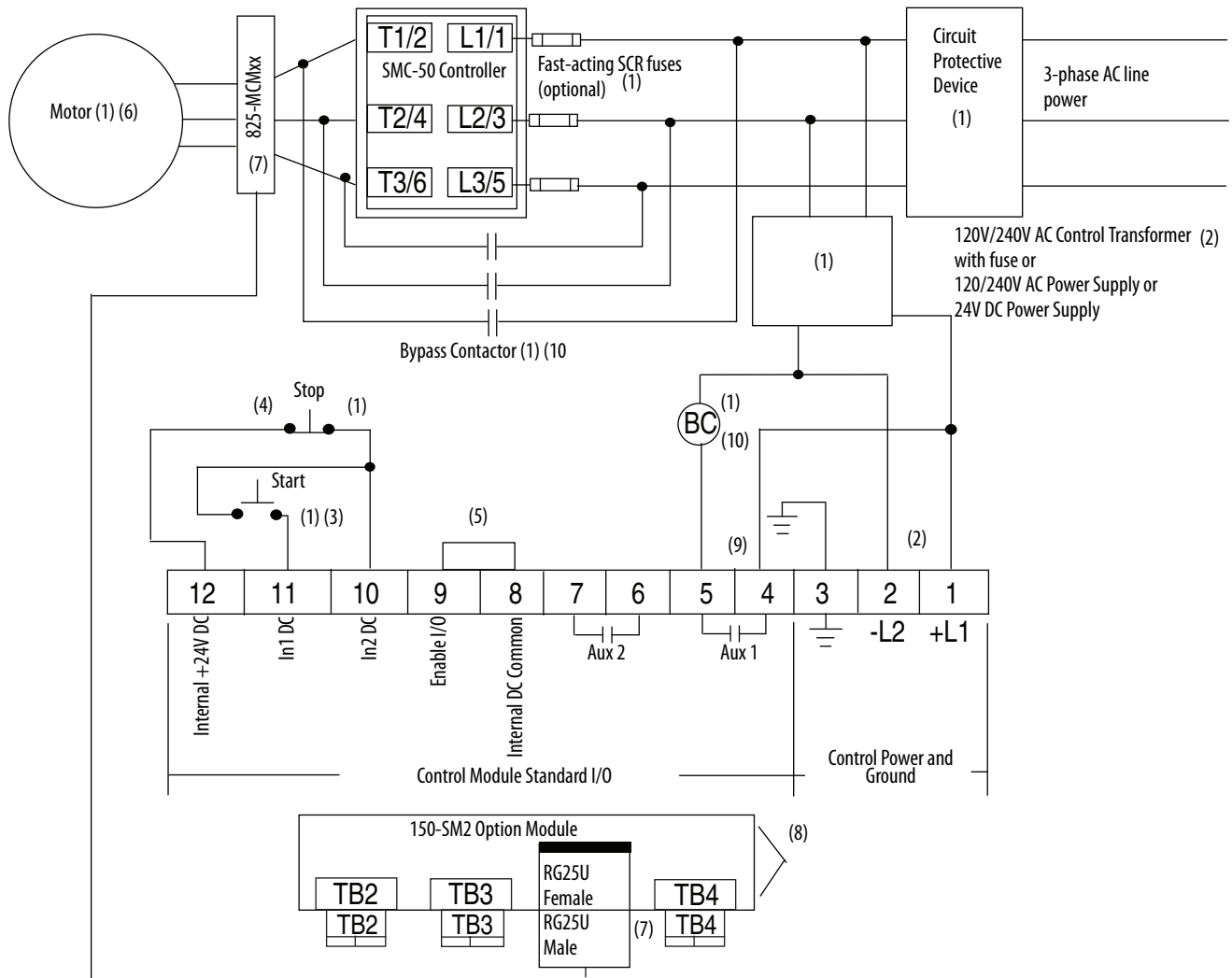

(1) Customer supplied.

(2) See the controller nameplate to verify control power input ratings (100...240V AC or 24V DC).

(3) Terminal 11 (In1 DC) 24V DC input is configured for START input using Parameter 56.

(4) Terminal 10 (In2 DC) 24V DC input configured for COAST, STOP OPTION, etc. using Parameter 57.

NOTE: The controller generates an I/O configuration fault if any input is configured for START or SLOW speed and no input is configured for COAST or STOP.

(5) A customer-supplied jumper is required to enable the controller I/O operation.

(6) Due to current leakage through an SCR in the OFF state (controller stopped), some form of upstream line power isolation is recommended if maintenance is required on the motor. See the Isolation Contactor Applications for details.

(7) In Bypass Contactor RUN operation, the 825-MCM and the 150-SM2 provide current-based protective feedback features including overload. Only the cable provided with the 825-MCM converter can be used in this configuration. The maximum cable length is 4 m, thus the 825-MCM must be located within 4 m of the SMC-50 controller.

(8) The order of the terminal numbers for the 150-SM2 module can be reversed depending on which expansion slot it is located in the control module. However, the function associated with the terminal number remains the same.

(9) The Aux 1 relay output is configured for external bypass using Parameter 172.

(10) In North America, size the bypass contactor per the motor Hp and FLA. In IEC, size the bypass contactor per the motor AC-1 rating. The short-circuit rating of the bypass contactor must be similar to the SMC-50 controller.

NOTE: In addition to a small amount of leakage current flowing through an SCR in the off-state, failure of one or more solid-state power switching components allows uncontrolled current to flow to the winding(s) of the motor. This could potentially result in overheating or damage to the motor. To prevent potential personal injury or equipment damage, the installation of an isolation contactor or shunt trip-type circuit breaker capable of interrupting the motor's locked rotor current on the line side of the SMC-50 controller is recommended. Operation of the isolation device should be coordinated using one of the SMC-50 controller Aux contacts configured to NORMAL.

Figure 43 - Hand-Off-Auto Control with Start/Stop Push Buttons—AC Control

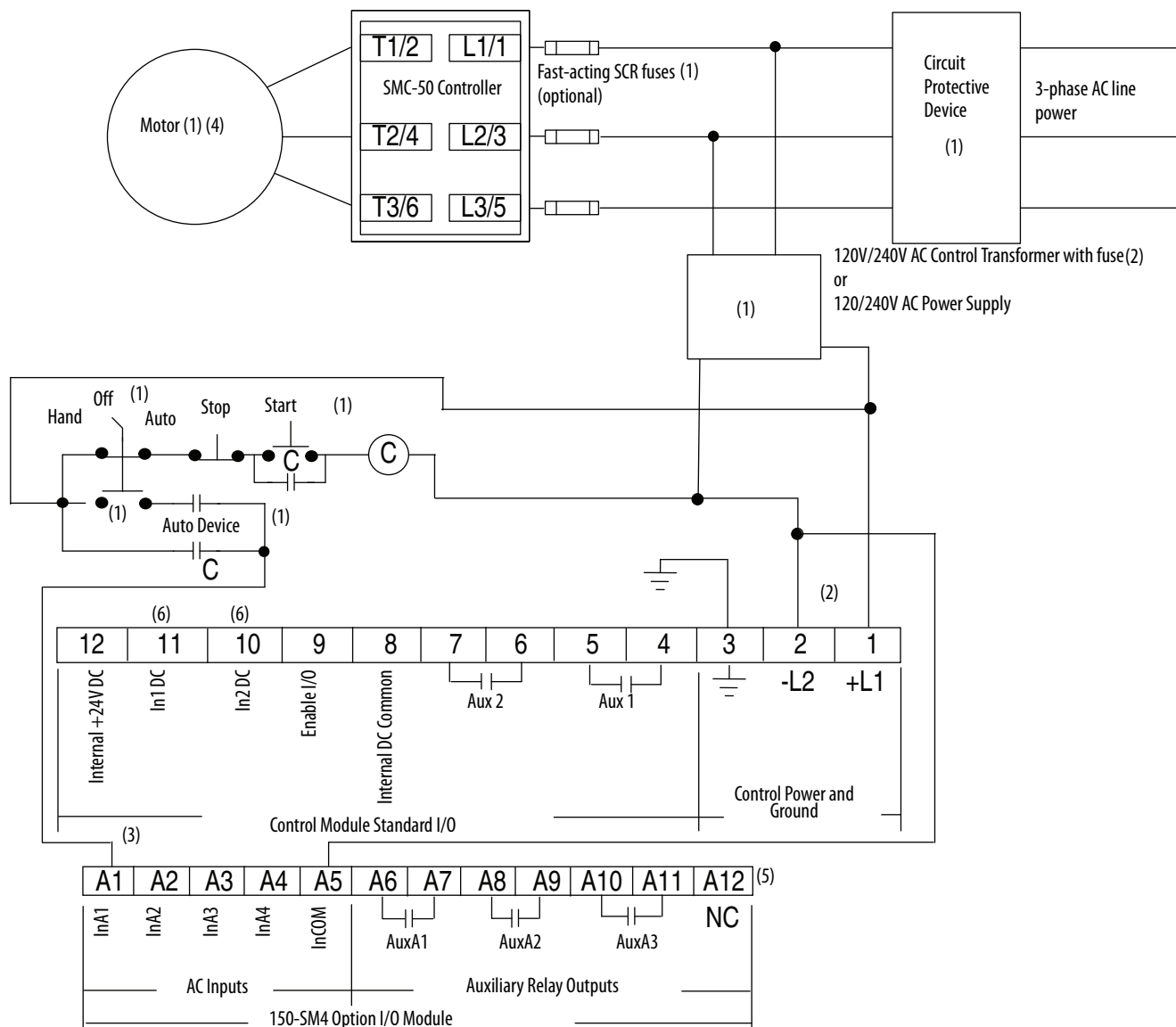

- (1) Customer supplied.
- (2) See the controller nameplate to verify control power input ratings (100...240V AC).
- (3) Terminal A1 (InA1) 100...240V AC input is configured for START/STOP or START/COAST using Parameter 7-2 (control module port 7, Start = Input High, Coast/Stop = Input Low).
- NOTE:** The controller generates an I/O configuration fault if any input is configured for START or SLOW speed and no input is configured for COAST or STOP.
- (4) Due to current leakage through an SCR in the OFF state (controller stopped), some form of upstream line power isolation is recommended if maintenance is required on the motor. See the Isolation Contactor Applications diagram for details.
- (5) The order of the terminal numbers for the option I/O module can be reversed depending on which expansion port it is located in on the control module. However, the function associated with the terminal number remains the same.
- (6) Configure both In1 (Input 1—Parameter 56) and In2 (Input 2—Parameter 57) to "Disable".
- NOTE:** In addition to a small amount of leakage current flowing through an SCR in the off-state, failure of one or more solid-state power switching components allows uncontrolled current to flow to the winding(s) of the motor. This could potentially result in overheating or damage to the motor. To prevent potential personal injury or equipment damage, the installation of an isolation contactor or shunt trip-type circuit breaker capable of interrupting the motor's locked rotor current on the line side of the SMC-50 controller is recommended. Operation of the isolation device should be coordinated using one of the SMC-50 controller Aux contacts configured to NORMAL.

Figure 44 - For Hand-Off-Auto (DPI) with Start/Stop Push Buttons—AC I/O

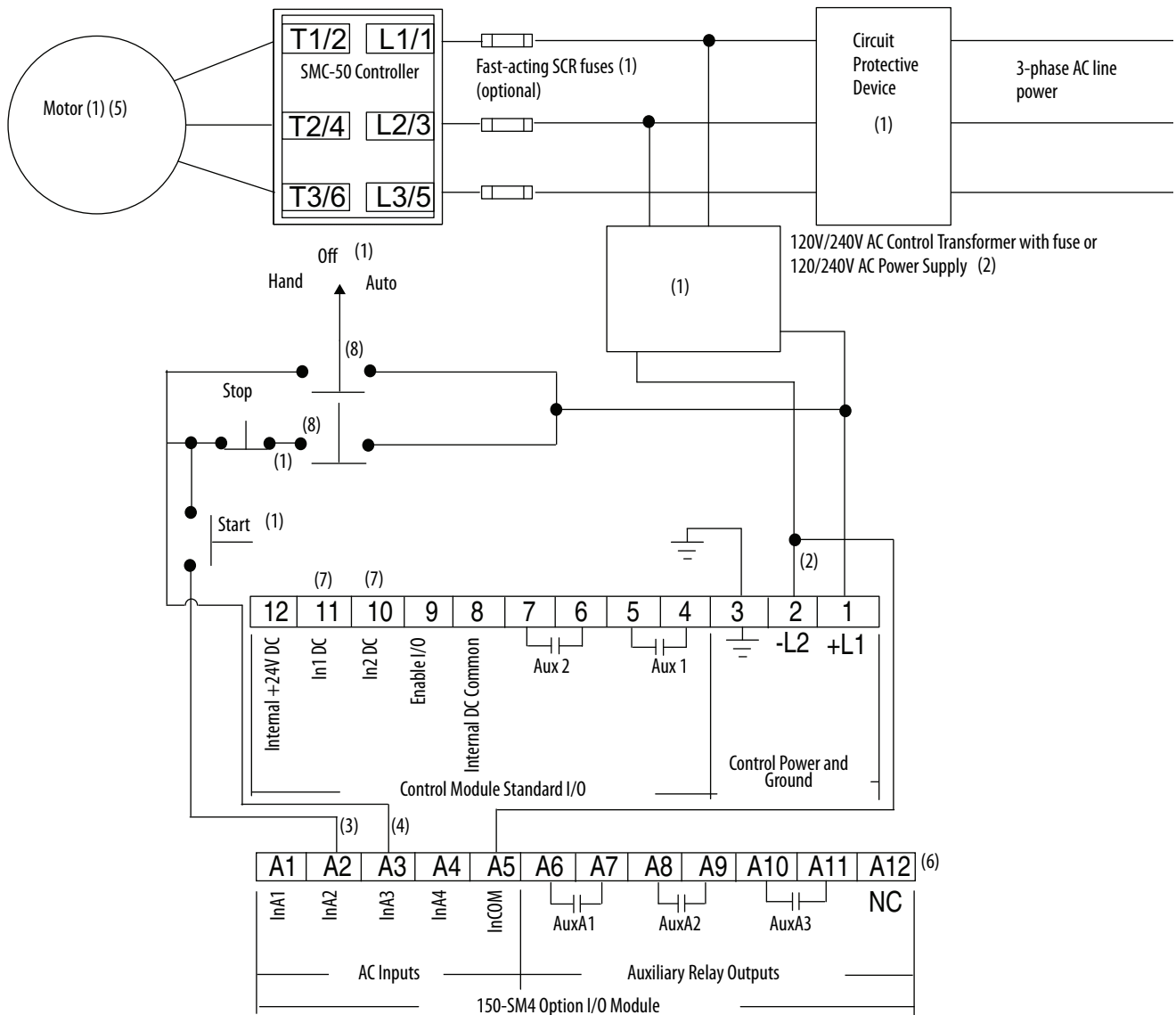

- (1) Customer supplied.
- (2) See the controller nameplate to verify control power input ratings (100...240V AC).
- (3) Option I/O Terminal A2 (InA2) 100...240V AC input is configured for START input using Parameter 7-4 (control module port 7).
- (4) Option I/O Terminal A3 (InA3) 100...240V AC input configured for COAST, STOP OPTION, etc. using Parameter 7-3 (control module port 7).
- NOTE:** The controller generates an I/O configuration fault if any input is configured for START or SLOW speed and no input is configured for COAST or STOP.
- (5) Due to current leakage through an SCR in the OFF state (controller stopped), some form of upstream line power isolation is recommended if maintenance is required on the motor. See the Isolation Contactor Applications diagram for details.
- (6) The order of the terminal numbers for the option I/O module can be reversed depending on which expansion port it is located in on the control module. However, the function associated with the terminal number remains the same.
- (7) Configure both In1 (Input 1—Parameter 56) and In2 (Input 2—Parameter 57) to "Disable".
- NOTE:** In addition to a small amount of leakage current flowing through an SCR in the off-state, failure of one or more solid-state power switching components allows uncontrolled current to flow to the winding(s) of the motor. This could potentially result in overheating or damage to the motor. To prevent potential personal injury or equipment damage, the installation of an isolation contactor or shunt trip-type circuit breaker capable of interrupting the motor's locked rotor current on the line side of the SMC-50 controller is recommended. Operation of the isolation device should be coordinated using one of the SMC-50 controller Aux contacts configured to NORMAL.
- (8) The switch is closed in this position.

Soft Stop, Pump Control, and Smart Motor Braking (SMB)

The following figure shows the typical wiring diagrams for the Soft Stop, Pump Control, and SMB options.

Figure 45 - Soft Stop, Pump Stop, or Braking Control Option, AC Control

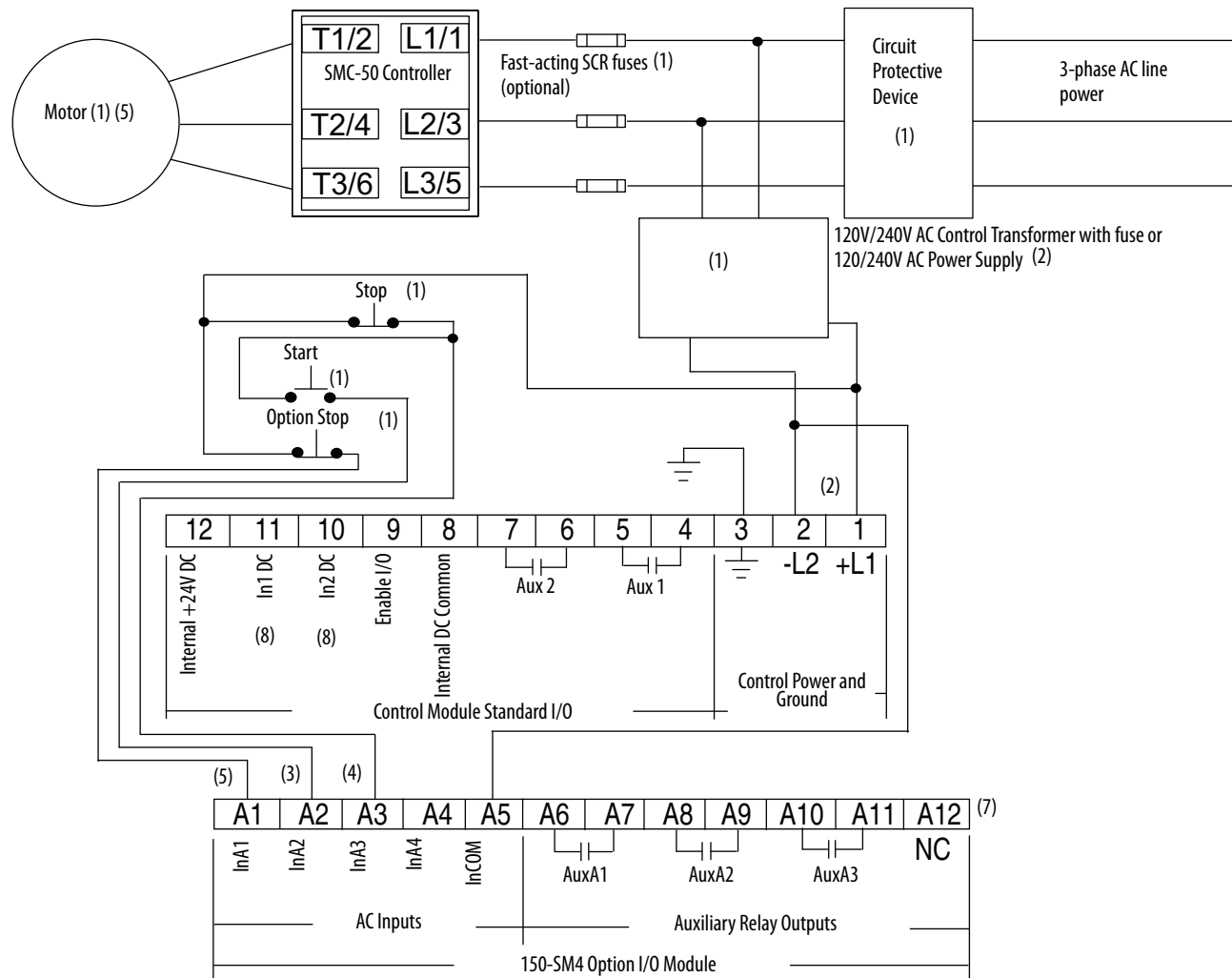

(1) Customer supplied.

(2) See the controller nameplate to verify control power input ratings (100...240V AC).

(3) Option I/O Terminal A2 (InA2) 100...240V AC input is configured for START input using Parameter 7-3 (contact module port 7).

(4) Option I/O Terminal A3 (InA3) 100...240V AC input configured for COAST using Parameter 7-4 (contact module port 7).

NOTE: The controller generates an I/O configuration fault if any input is configured for START or SLOW speed and no input is configured for COAST or STOP.

(5) Option I/O module Terminal A1 (InA1) 120/240V AC input is configured for STOP OPTION using Parameter 7-2 (contact module port 7).

(6) Due to current leakage through an SCR in the OFF state (controller stopped), some form of upstream line power isolation is recommended if maintenance is required on the motor. See the Isolation Contactor Applications diagram for details.

NOTE: In addition to a small amount of leakage current flowing through an SCR in the off-state, failure of one or more solid-state power switching components allows uncontrolled current to flow to the winding(s) of the motor. This could potentially result in overheating or damage to the motor. To prevent potential personal injury or equipment damage, the installation of an isolation contactor or shunt trip-type circuit breaker capable of interrupting the motor's locked rotor current on the line side of the SMC-50 controller is recommended. Operation of the isolation device should be coordinated using one of the SMC-50 controller Aux contacts configured to NORMAL.

(7) The order of the terminal numbers for the option I/O module can be reversed depending on which expansion port it is located in on the control module. However, the function associated with the terminal number remains the same.

(8) Configure both In1 (Input 1—Parameter 56) and In2 (Input 2—Parameter 57) to "Disable".

Slow Speed with Braking

Figure 46 - For Isolation Contactor with STOP Option Applications, AC Inputs

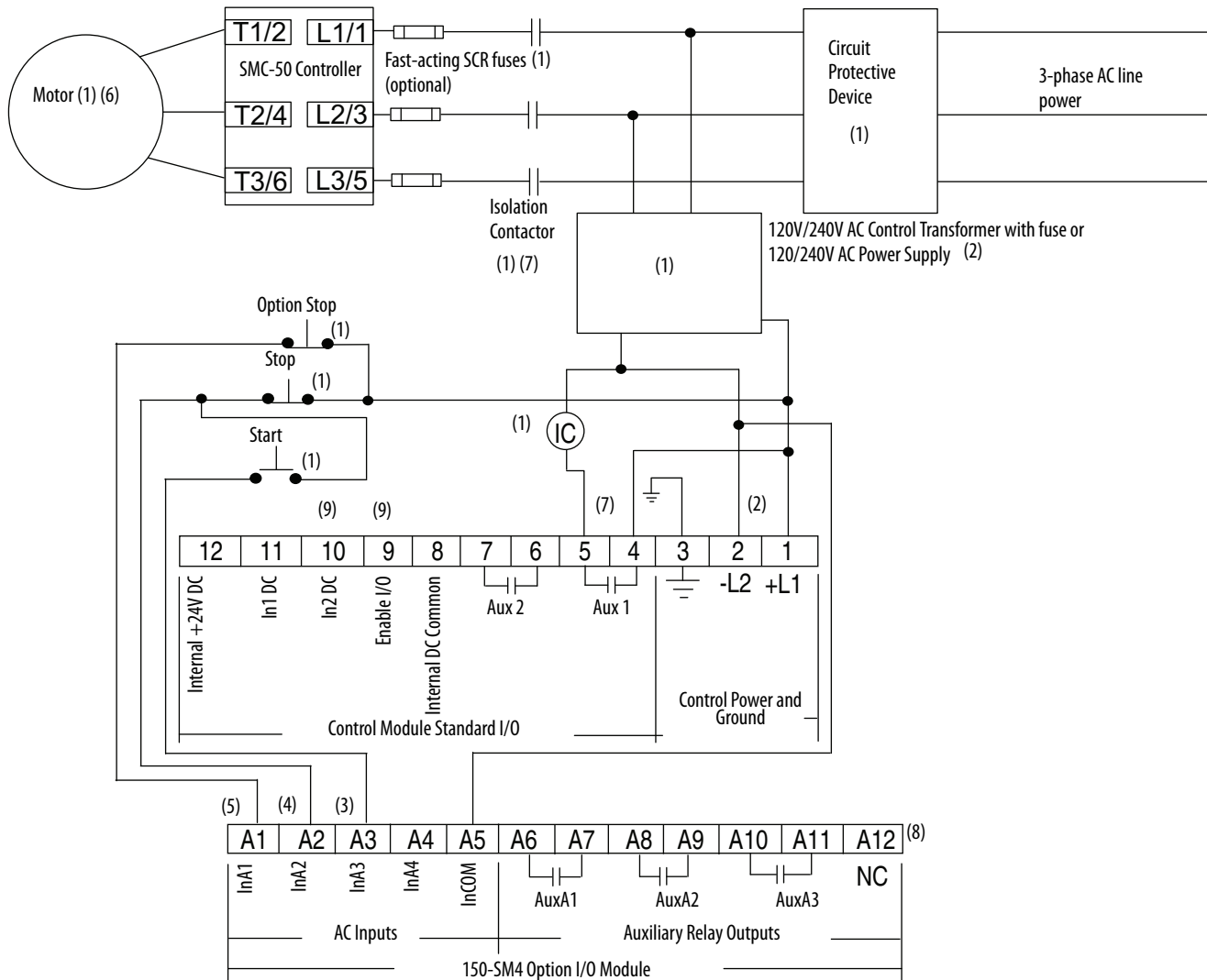

- (1) Customer supplied.
- (2) See the controller nameplate to verify control power input ratings (100...240V AC).
- (3) Option I/O Terminal A3 (InA3) 100...240V AC input is configured for START input using Parameter 7-4 (control module port 7).
- (4) Option I/O Terminal A2 (InA2) 100...240V AC input configured for COAST using Parameter 7-3 (control module port 7).
- NOTE:** The controller generates an I/O configuration fault if any input is configured for START or SLOW speed and no input is configured for COAST or STOP.
- (5) Option I/O module Terminal A1 (InA1) 100...240V AC input is configured for STOP OPTION using Parameter 7-2 (control module port 7).
- (6) Due to current leakage through an SCR in the OFF state (controller stopped), some form of upstream line power isolation (for example, the one shown in this diagram) is recommended if maintenance is required on the motor.
- NOTE:** In addition to a small amount of leakage current flowing through an SCR in the off-state, failure of one or more solid-state power switching components allows uncontrolled current to flow to the winding(s) of the motor. This could potentially result in overheating or damage to the motor. To prevent potential personal injury or equipment damage, the installation of an isolation contactor or shunt trip-type circuit breaker capable of interrupting the motor's locked rotor current on the line side of the SMC-50 controller is recommended. Operation of the isolation device should be coordinated using one of the SMC-50 controller Aux contacts configured to NORMAL.
- (7) Configure Aux1 to NORMAL using Parameter 172. NORMAL = Aux1 contact closes to energize the IC coil with the START push button and open to de-energize when the stop maneuver, initiated by the STOP push button, is complete.
- (8) The order of the terminal numbers for the option I/O module can be reversed depending on which expansion port it is located in on the control module. However, the function associated with the terminal number remains the same.
- (9) Configure both In1 (Input 1—Parameter 56) and In2 (Input 2—Parameter 57) to "Disable".

Figure 47 - For Isolation Contactor and Slow Speed with Braking Application— AC Control

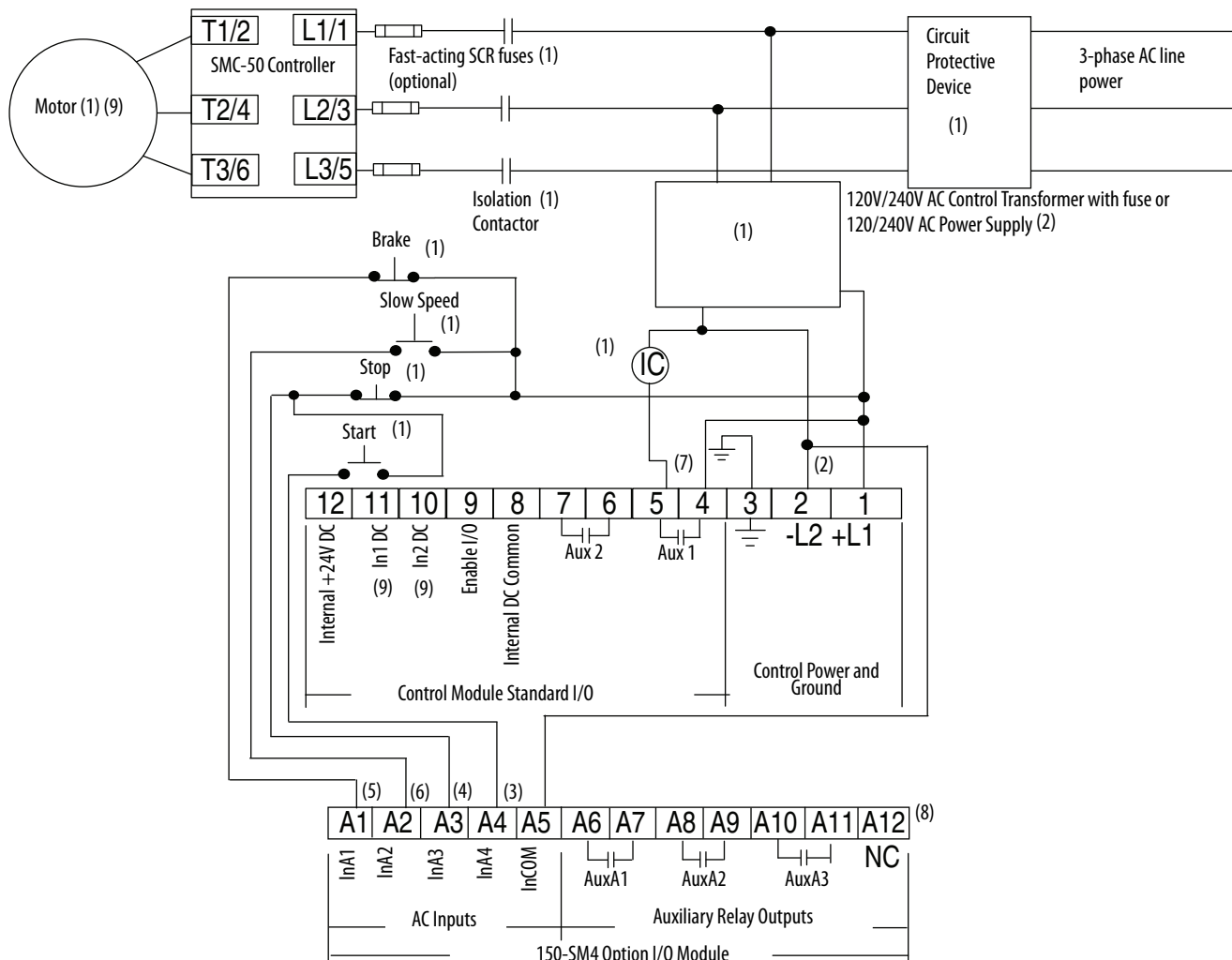

- (1) Customer supplied.
- (2) See the controller nameplate to verify control power input ratings (100...240V AC).
- (3) Option I/O Terminal A4 (InA4) 100...240V AC input is configured for START input using Parameter 7-5 (control module port 7).
- (4) Option I/O Terminal A3 (InA3) 100...240V AC input configured for COAST, etc. using Parameter 7-4 (control module port 7).
- NOTE:** The controller generates an I/O configuration fault if any input is configured for START or SLOW speed and no input is configured for COAST or STOP.
- (5) Option I/O module Terminal A1 (InA1) 100...240V AC input is configured for STOP OPTION using Parameter 7-2 (control module port 7). Set STOP MODE, Parameter 65, to SMB.
- (6) Option I/O module Terminal A2 (InA2) 100...240V AC input is configured for SLOW SPEED using Parameter 7-3 (control module port 7).
- (7) Configure Aux1 to NORMAL using Parameter 172. NORMAL = Aux1 contact closes to energize the IC coil with the START push button and open to de-energize when the stop maneuver, initiated by the STOP push button, is complete.
- (8) The order of the terminal numbers for the option I/O module can be reversed depending on which expansion port it is located in on the control module. However, the function associated with the terminal number remains the same.
- (9) Configure both In1 (Input 1—Parameter 56) and In2 (Input 2—Parameter 57) to "Disable".
- NOTE:** In addition to a small amount of leakage current flowing through an SCR in the off-state, failure of one or more solid-state power switching components allows uncontrolled current to flow to the winding(s) of the motor. This could potentially result in overheating or damage to the motor. To prevent potential personal injury or equipment damage, the installation of an isolation contactor (as shown in this diagram) or shunt trip-type circuit breaker capable of interrupting the motor's locked rotor current on the line side of the SMC-50 controller is recommended. Operation of the isolation device should be coordinated using one of the SMC-50 controller Aux contacts configured to NORMAL.

Preset Slow Speed

Figure 48 - For Preset Slow Speed Control—AC I/O

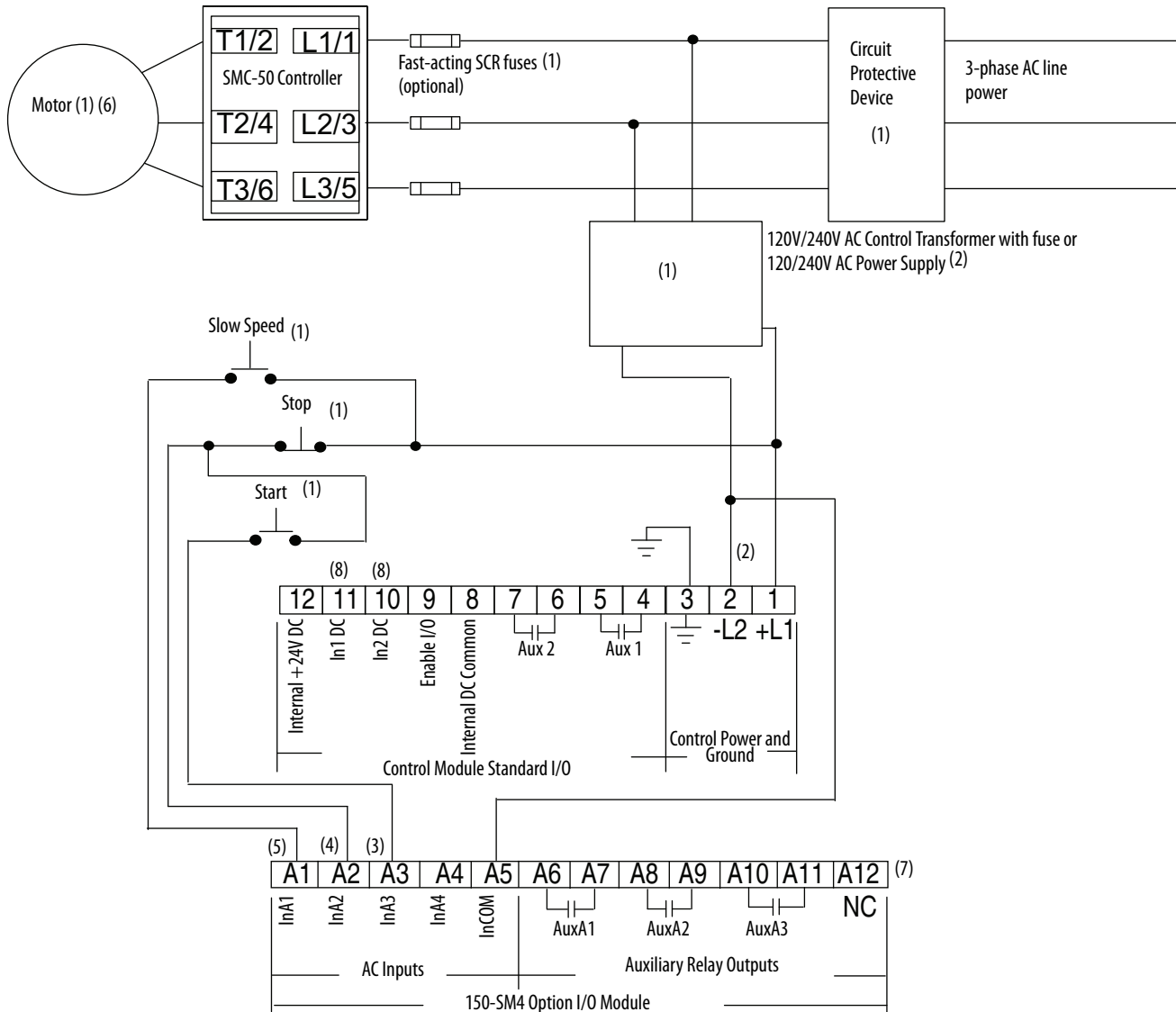

- (1) Customer supplied.
- (2) See the controller nameplate to verify control power input ratings (100...240V AC).
- (3) Option I/O Terminal A3 (InA3) 100...240V AC input is configured for START input using Parameter 7-4 (control module port 7).
NOTE: The controller generates an I/O configuration fault if any input is configured for START or SLOW speed and no input is configured for COAST or STOP.
- (4) Option I/O Terminal A2 (InA2) 100...240V AC input configured for COAST, Stop Option, etc. using Parameter 7-3 (control module port 7).
- (5) Option I/O terminal A1 (InA1) 120/240V AC input configured for SLOW SPEED using Parameter 7-2 (control module port 7)
- (6) Due to current leakage through an SCR in the OFF state (controller stopped), some form of upstream line power isolation is recommended if maintenance is required on the motor. See the Isolation Contactor Applications diagram for details.
- (7) The order of the terminal numbers for the option I/O module can be reversed depending on which expansion port it is located in on the control module. However, the function associated with the terminal number remains the same.
- (8) Configure both In1 (Input 1—Parameter 56) and In2 (Input 2—Parameter 57) to "Disable".
NOTE: In addition to a small amount of leakage current flowing through an SCR in the off-state, failure of one or more solid-state power switching components allows uncontrolled current to flow to the winding(s) of the motor. This could potentially result in overheating or damage to the motor. To prevent potential personal injury or equipment damage, the installation of an isolation contactor or shunt trip-type circuit breaker capable of interrupting the motor's locked rotor current on the line side of the SMC-50 controller is recommended. Operation of the isolation device should be coordinated using one of the SMC-50 controller Aux contacts configured to NORMAL.

Figure 49 - For Preset Slow Speed Control for Hand-OFF-Auto (DPI) — AC I/O

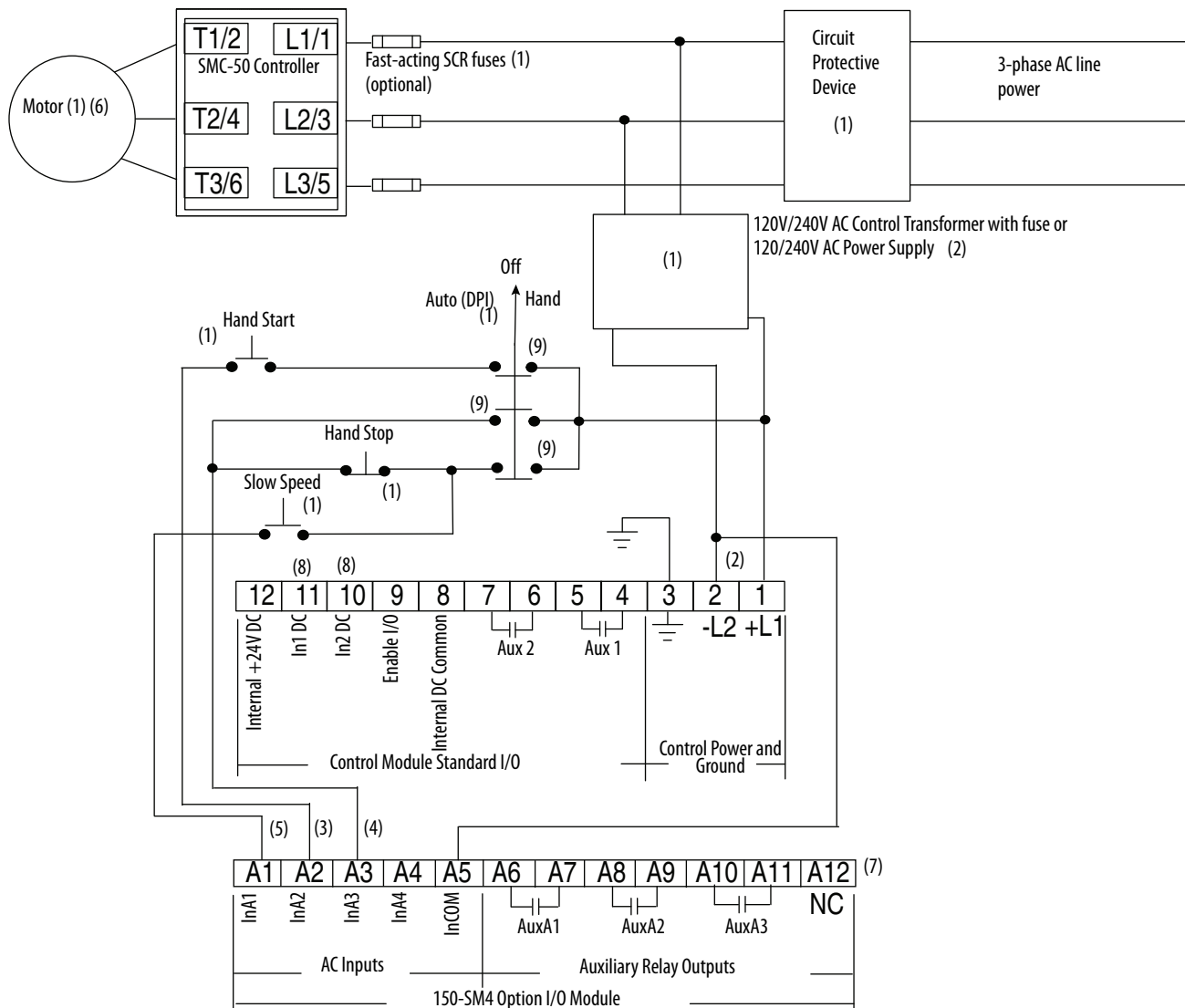

- (1) Customer supplied.
- (2) See the controller nameplate to verify control power input ratings (100...240V AC).
- (3) Option I/O Terminal A2 (InA2) 100...240V AC input is configured for START input using Parameter 7-3 (control module port 7).
NOTE: The controller generates an I/O configuration fault if any input is configured for START or SLOW speed and no input is configured for COAST or STOP.
- (4) Option I/O Terminal A3 (InA3) 100...240V AC input configured for COAST, Stop Option, etc. using Parameter 7-4 (control module port 7).
- (5) Option I/O Terminal A1 (InA1) 120/240V input configured for SLOW SPEED using Parameter 7-2 (control module port 7).
- (6) Due to current leakage through an SCR in the OFF state (controller stopped), some form of upstream line power isolation is recommended if maintenance is required on the motor. See the Isolation Contactor Application diagram for details.
- (7) The order of the terminal numbers for the option I/O module can be reversed depending on which expansion port it is located in on the control module. However, the function associated with the terminal number remains the same.
- (8) Configure both In1 (Input 1—Parameter 56) and In2 (Input 2—Parameter 57) to "Disable".
- NOTE:** In addition to a small amount of leakage current flowing through an SCR in the off-state, failure of one or more solid-state power switching components allows uncontrolled current to flow to the winding(s) of the motor. This could potentially result in overheating or damage to the motor. To prevent potential personal injury or equipment damage, the installation of an isolation contactor or shunt trip-type circuit breaker capable of interrupting the motor's locked rotor current on the line side of the SMC-50 controller is recommended. Operation of the isolation device should be coordinated using one of the SMC-50 controller Aux contacts configured to NORMAL.
- (9) The switch is closed in this position.

Figure 50 - Accu-Stop—AC I/O

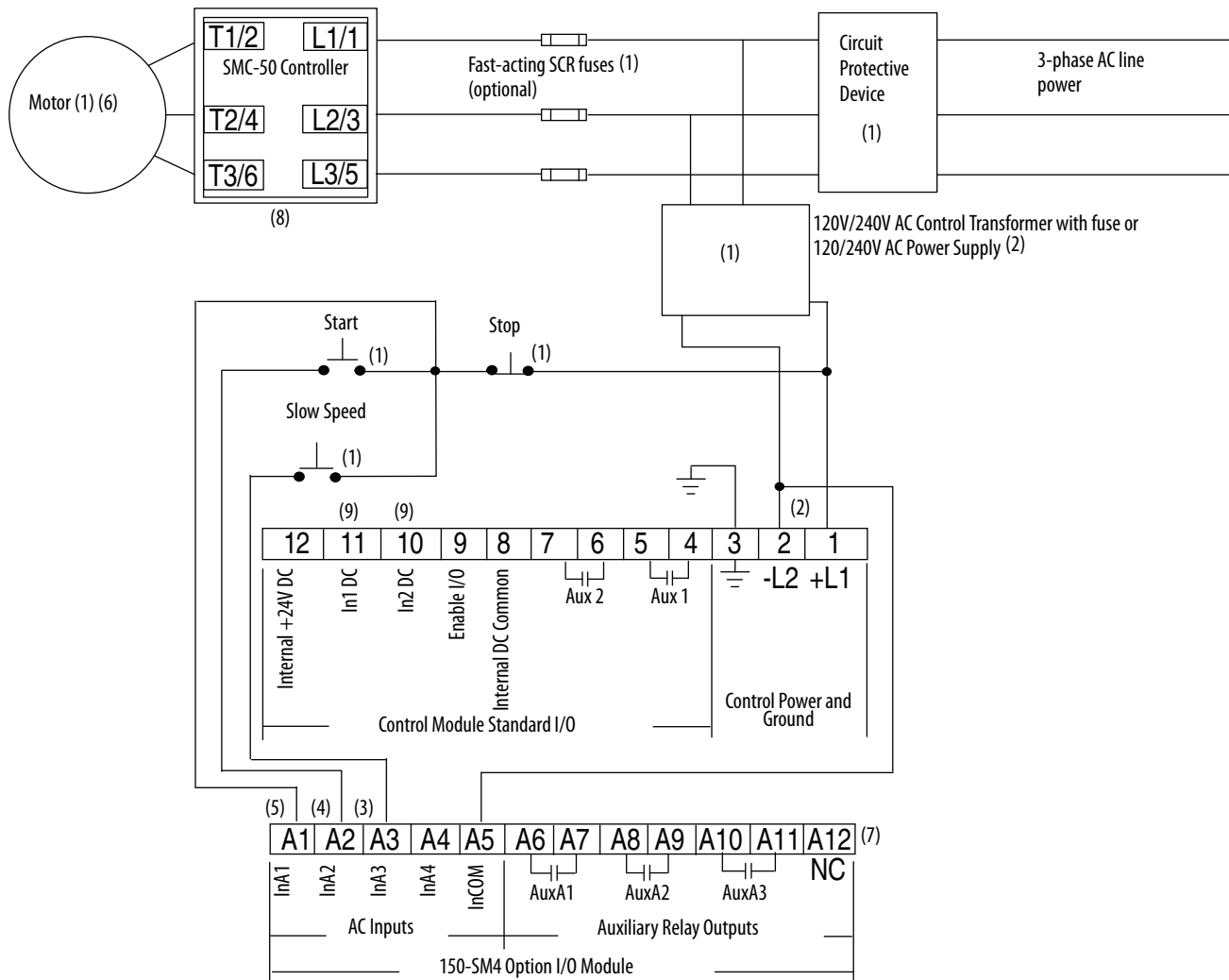

- (1) Customer supplied.
- (2) See the controller nameplate to verify control power input ratings (100...240V AC).
- (3) Option I/O Terminal A3 (InA3) 100...240V AC input configured for SLOW SPEED, Stop Option, etc. using Parameter 7-4 (control module port 7).
- NOTE:** The controller generates an I/O configuration fault if any input is configured for START or SLOW speed and no input is configured for COAST or STOP.
- (4) Option I/O Terminal A2 (InA2) 100...240V AC input is configured for SART input using Parameter 7-3 (control module port 7).
- (5) Option I/O Terminal A1 (InA1) 120/240V Input configured for COAST using Parameter 7-2 (control module port 7).
- (6) Due to current leakage through an SCR in the OFF state (controller stopped), some form of upstream line power isolation is recommended if maintenance is required on the motor. See the Isolation Contactor Applications diagram for details.
- (7) The order of the terminal numbers for the option I/O module can be reversed depending on which expansion port it is located in on the control module. However, the function associated with the terminal number remains the same.
- (8) Configure Stop Mode to SMB using Parameter 65; Braking Current using Parameter 69; Slow Speed using Parameter 72; and Slow Brake using Parameter 73 (Parameter 73 = 0 results in Coast).
- (9) Configure both In1 (Input 1 - Parameter 56) and In2 (Input 2 - Parameter 57) to DISABLE.
- NOTE:** In addition to a small amount of leakage current flowing through an SCR in the off-state, failure of one or more solid-state power switching components allows uncontrolled current to flow to the winding(s) of the motor. This could potentially result in overheating or damage to the motor. To prevent potential personal injury or equipment damage, the installation of an isolation contactor or shunt trip-type circuit breaker capable of interrupting the motor's locked rotor current on the line side of the SMC-50 controller is recommended. Operation of the isolation device should be coordinated using one of the SMC-50 controller Aux contacts configured to NORMAL.

Fan Wiring

Fans for the SMC-50 controllers should be wired according to the instructions in this section.

Integrated Bypass Units

For units with integrated bypass, you should wire the fans as shown in [Figure 51](#).

Figure 51 - Fan Wiring—Integrated Bypass Units

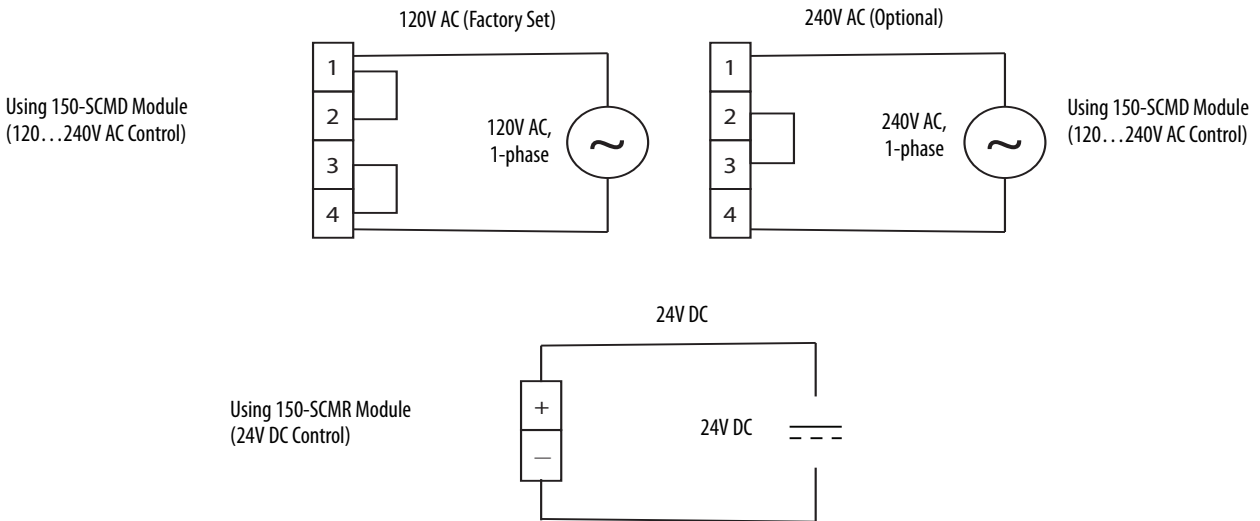

Solid-state Units

Solid-state units do not require any additional wiring. The fans are connected internally.

Upgraded Units

For SMC Flex controller-to-SMC-50 controller control upgrades, the fans remain connected as they were in the SMC Flex controller. You do not need to change any wiring.

Notes:

Operating Modes

Operation

The SMC-50 controller with an internal bypass power structure can operate standard squirrel-cage induction motors rated 27...480 A or star-delta (wye-delta) type motors rated 47...831 A operated inside-the-delta.

The SMC-50 controller with a solid-state power structure can operate standard squirrel-cage induction motors rated 30...520 A or star-delta (wye-delta) type motors rated 52...900 A operated inside-the-delta.

IMPORTANT Verify line and control voltage values on the product before applying power.

Motor Configuration

Line-connected wye, line-connected delta, and inside-the-delta motor configurations are possible with the SMC-50 controller. The motor tuning feature of the SMC-50 controller automatically determines the motor connection. Motor tuning is done automatically by the controller on initial motor start or forced to occur by the user. You can also enter the configuration of the Motor Connection, Parameter 44, into the SMC-50 controller. You must enter the Motor Line Voltage rating, Parameter 46, into the controller to enable the motor protection features to function (default 480V).

Motor Tuning

The SMC-50 controller performs the motor tuning process on the initial start sequence of the motor. Motor tuning includes the identification of the motor parameters and the detection of the motor connection type (Line or Delta). The SMC-50 controller uses the motor tuning data in its control algorithm. During the tuning process, the motor does not turn and makes some audible noise, including pulsing and buzzing. The time to complete the tuning process is approximately 10 to 20 seconds, but varies based on the size and characteristics of the individual motor being used. After successful completion of the tuning process, the motor starts based on the user-programmed start profile. If you interrupt the tuning process by giving a stop command or removing power from the unit, the tuning process repeats on the next start command. Subsequent starts of the motor after a successful tuning do not perform the tuning process.

Note: With some generators, you may have difficulty with the motor tuning. If so, try tuning the motor while it is connected to line power. Contact Rockwell Automation technical support if you need assistance.

After the initial successful tuning of the motor, You can re-start the process via one of the following methods:

1. Change the status of Force Tuning, Parameter 194, to TRUE by using a configuration tool (such as a HIM) with the motor stopped. During the next start cycle, the tuning process occurs and Parameter 194 will change back to FALSE. **OR**
2. Press the "HOLD TO TEST/PUSH TO RESET" push button, located on the front of the controller, for ten seconds with the motor stopped. During the next start cycle, the tuning process occurs. The controller's status LED will flash amber, indicating that Tuning occurs on the next start cycle. **OR**
3. When the controller processes a "Load Factory Defaults" command via Parameter Management, Parameter 229.

TIP If a motor that is smaller or larger than normal is used for initial system testing, you must perform a motor tuning cycle on the motor used in the final installation.

[Table 6](#) lists Parameter 194 Force Tuning along with the key motor parameters checked by the SMC-50 controller during a motor tuning cycle.

Table 6 - Key Motor Parameters Checked During a Motor Tuning Cycle

Parameter Number	Parameter Name	Minimum/Maximum Values	Default Value	Access	Units
194	Force Tuning	FALSE/TRUE	TRUE	R/W	—
195	Stator R	0.00...50.00	0.00...50.00	R	Ohms
196	Total R	0.00...50.00	0.00...50.00		Ohms
197	Coupling Factor	0.00...10.00	0.00...10.00		mH
198	Inductance	0.00...1000.00	0.00...1000.00		—
45	Motor Connection	Line/Delta	Line		

Resistive Loads

The resistive load feature lets you control voltage from 1...100% of full voltage with simple settings.

- Setting the Load Type, Parameter 347 to Resistive.
- Select the reference source, Ref Source Parameter 348 to either Output V Ref (Output Voltage Reference), analog card 150-SM3 input or DeviceLogix output.

If the Ref Source is selected in Parameter 348, then you need to set Output V Ref using Parameter 349. You also need to set the line voltage, Parameter 46, and Motor FLC, Parameter 78.

The Motor FLC when resistive load is selected is actually resistance full load current; you need to calculate this if you do not know the value for the load. If needed, You can also set Current Limit Level, Parameter 53, to limit the amount of current that is supplied to the resistors. You can change the value of the reference source while the SMC-50 controller is in a run state.



ATTENTION: You can not use the resistive load feature on motor loads.

Three-phase Balanced Loads

Figure 52 - Delta- and Wye-connected Resistive Loads

Variable	Definition
R	Resistance
R ₁	Branch 1 resistance
R ₂	Branch 2 resistance
R ₃	Branch 3 resistance
E _L	Line voltage
E _p	Phase voltage
I _L	Line current
I _p	Phase current
W	Wattage
PF	Power factor

Wattage Calculations:

Wye: $W = E_L^2 / R = 3(E_p^2) / R$

Delta: $W = 3(E_L^2) / R$

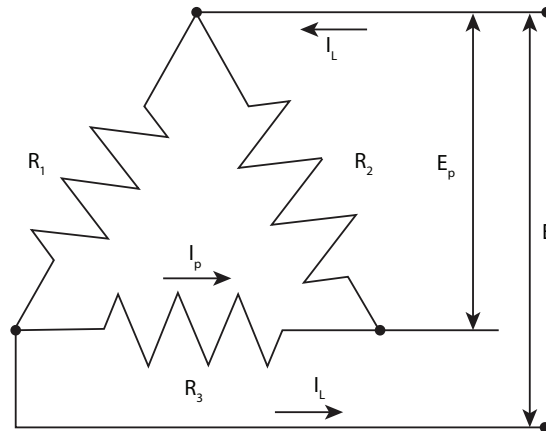

Delta

$$E_L = E_p$$

$$I_L = 1.73 \times I_p$$

$$I_p = I_L / 1.73$$

$$P = I_L \times E_L \times 1.73 \times PF$$

$$W = 1.73 \times I_L \times E_L$$

Note: With resistive loads, PF = 1.0 and therefore P = W

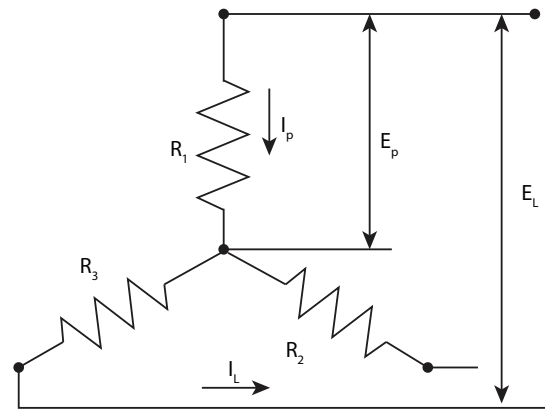

Wye

$$I_L = I_p$$

$$E_L = 1.73 \times E_p$$

$$E_p = E_L / 1.73$$

$$P = I_L \times E_L \times 1.73 \times PF$$

$$W = 1.73 \times I_L \times E_L$$

Figure 53 - Delta Configuration for SMC-50 Controller

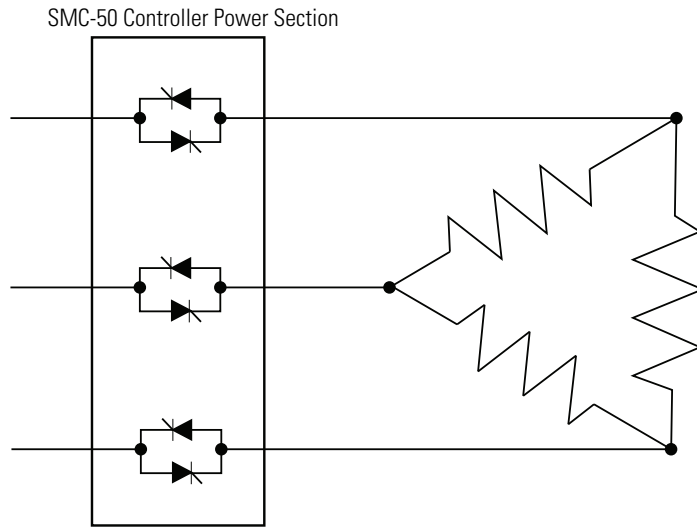

Figure 54 - Grounded Wye Configuration for SMC-50 Controller

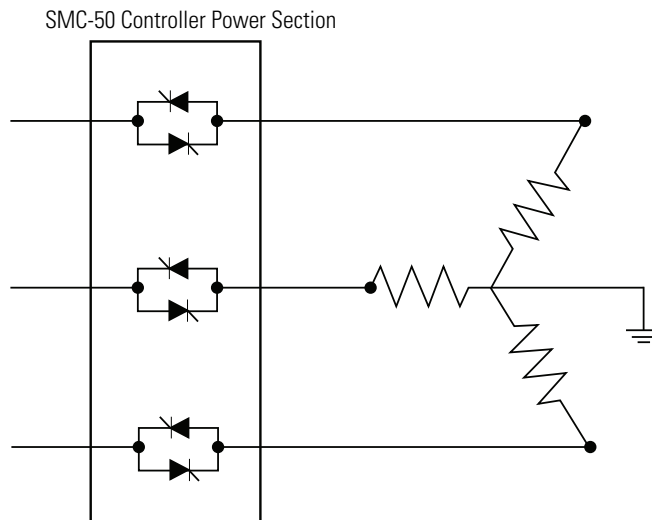

Figure 55 - Inside-the-Delta Configuration for SMC-50 Controller

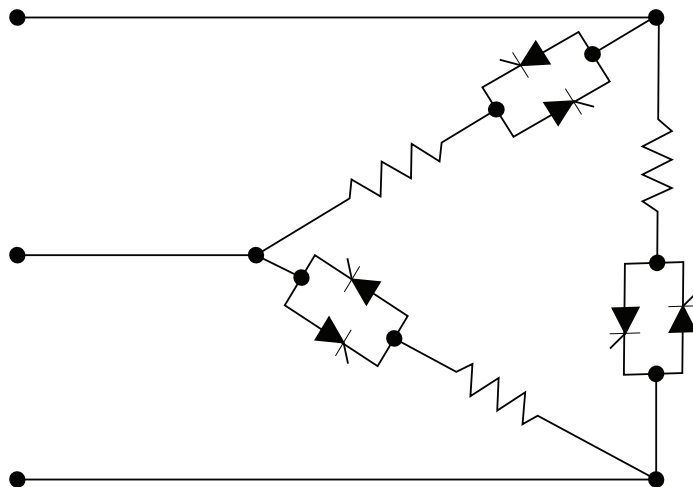

Table 7 - SMC-50 Controller Resistive Load Parameters

Parameter Number	Parameter Name	Minimum/Maximum Values	Default Value	Access	Unit
347	Load Type	Motor/Resistive	Motor	Read/Write	—
348	Ref Source	Output V Ref P7 In1 P7 In2 P8 In1 P8 In2 P9 In1 P9 In2 DLX Output 1 DLX Output 2	Output V Ref		—
349	Output V Ref	1...100	1		%
46	Line Voltage	0...700	400		Volts
53	Cur Limit Level	50...600	350		%FLC
78	Motor FLC ⁽¹⁾	1.0...2200.0	1.0		Amps

(1) You must calculate Motor FLC for the resistive load current based on the watts, voltage and configuration.

Starting Modes

Overview

The SMC-50 controller starting mode is configured using Starting Mode, Parameter 49. The available starting modes are: Soft Start [default], Current Limit, Torque Ramp, Linear Speed (Linear Acceleration), Pump Start, and Full Voltage.

Linear Speed (Linear Acceleration)

Set Starting Mode (Parameter 49) = Linear Speed.

The SMC-50 can start the motor following a timed linear ramp. The Ramp Time, Parameter 50, is selectable from 0.0...1000.0 seconds and determines the time the motor will ramp from a zero speed to full speed condition. An Initial Torque value, Parameter 51, sets the starting torque supplied to the motor from the controller. A current limit setting (50...600% selectable of motor FLC) is also available. If the controller reaches the current limit setpoint, the acceleration ramp will stop. When the unit comes out of current limit, the linear ramp will resume.

TIP Kickstart is not available with this starting mode.

[Figure 56](#) provides a graphical example of a linear acceleration and [Table 8](#) provides a list of linear acceleration parameters.

Figure 56 - Linear Speed Acceleration Timing Diagram

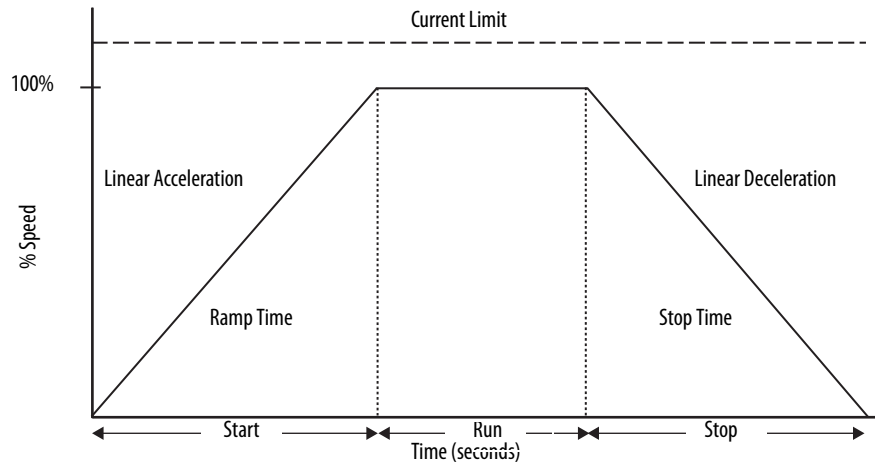

Table 8 - Linear Acceleration Mode Parameter List

Parameter Number	Parameter Name	Minimum/Maximum Values	Default Value	Access	Units
50	Ramp Time	0.0...1000.0	10.0	R/W	SEC
51	Initial Torque	0...90	70		%LRT
53	Cur Limit Level	50...600	350		%FLC
78	Motor FLC	1.0...2200.0	1.0		Amps
199	Speed PGain	0...10000	1000		—

Soft Start

Set Starting Mode (Parameter 49) = Soft Start. This is the factory default value.

This mode has the most general applications. The motor is given an initial torque setting using Parameter 51, which is user-adjustable from 0...90% of locked rotor torque. From the initial torque level, the output voltage to the motor is linearly increased during the acceleration ramp time. The acceleration ramp time is adjustable from 0...1000 seconds using Parameter 50.

During soft start, a current limit override (50...600% FLC) is also available to limit current throughout the start cycle using Parameter 53. The controller has Up-to-Speed (UTS) detection to determine when the motor is at full speed. If the motor reaches UTS before the end of the ramp time, the SMC-50 controller applies full voltage to the motor and the soft start is ended. The UTS level can be configured in percent of the SMC-50 controller’s applied motor voltage using Parameter 186. The full Soft Start parameter list can be found in [Table 9](#).

TIP If the controller is detecting UTS too soon, the UTS level should be increased. This typically occurs in very high efficiency motors. If the controller is detecting UTS too late or not at all, the UTS level should be lowered. This typically occurs in very low efficiency motors. See [Timed Start on page 88](#) for additional details.

Figure 57 - Soft Start Timing Diagram

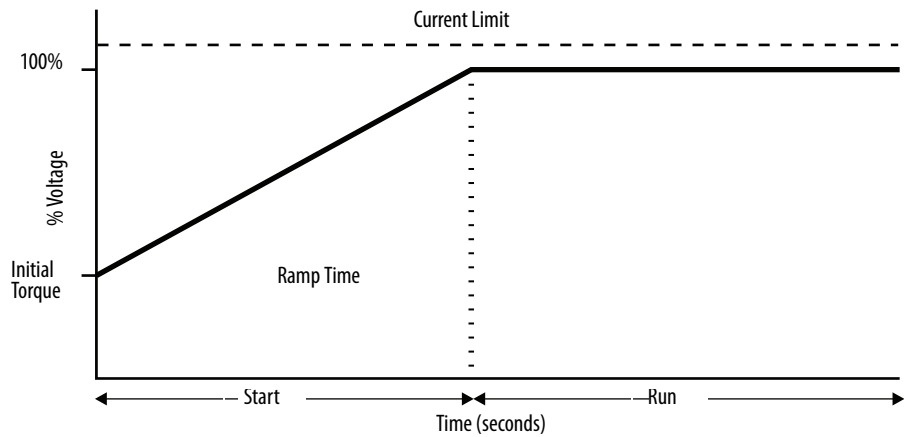

Table 9 - Soft Start Mode Parameter List

Parameter Number	Parameter Name	Minimum/Maximum Values	Default Value	Access	Units
50	Ramp Time	0.0...1000.0	10.0	R/W	SEC
51	Initial Torque	0...90	70		%LRT
53	Cur Limit Level	50...600	350		%FLC
54	Kickstart Time	0.0...2.0	0.0		SEC
55	Kickstart Level	0.0...90	0.0		%LRT
182	Start Delay	0.0...30	0.0		SEC
186	UTS Level	0...100	75		%
78	Motor FLC	1.0...2200.0	1.0		Amps

Selectable Kickstart

This feature provides a torque (current) boost at startup to break away loads that require a pulse of high torque to get started. The amount of torque pulse is selectable from 0...90% of locked rotor torque using Kickstart Level, Parameter 55. The time duration for the selectable kickstart is user-adjustable from 0.0...2.0 seconds using Kickstart Time, Parameter 54.

Kickstart is available in Soft Start, Current Limit, Pump, and Torque Control starting modes.

[Figure 58](#) provides a graphical representation of Kickstart. [Table 10](#) provides the Kickstart Mode Parameter List.

Figure 58 - Selectable Kickstart Timing Diagram

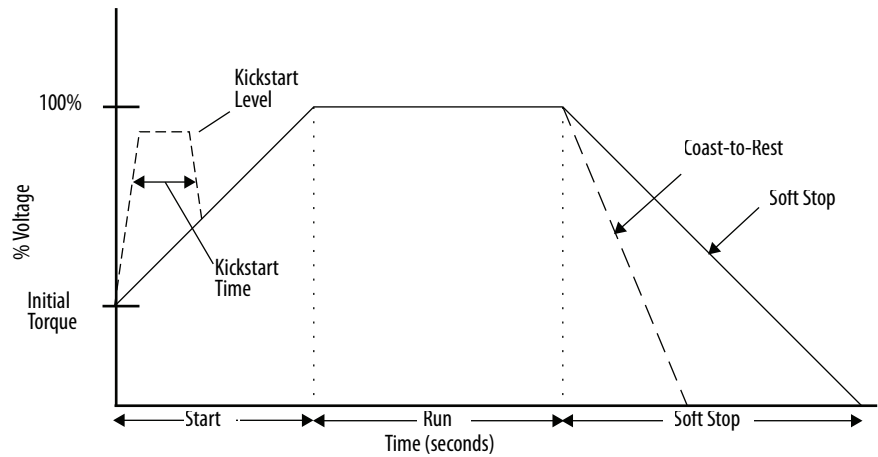

Table 10 - Kickstart Mode Parameter List

Parameter Number	Parameter Name	Minimum/Maximum Values	Default Value	Access	Units
54	Kickstart Time	0.0...2.0	0.0	R/W	SEC
55	Kickstart Level	0.0...90	0.0		%LRT

Current Limit Start

Set Starting Mode (Parameter 49) = Current Limit.

This starting mode provides a true current limit start, and is used when it is required to limit the maximum starting current to the load. This is accomplished using Current Limit Level, Parameter 53, which is user-adjustable from 50...600% of the motor full load current rating (FLC) and Ramp Time, Parameter 50, which is user-adjustable from 0.0...1000.0 seconds. For current limit, the Ramp Time is the time the controller will hold the current limit level until switching to full voltage. If the controller senses that the motor has reached the UTS condition during the current limit starting mode, the current limit ramp will end. As with Soft Start, the UTS level can be modified to account for load or motor characteristics. If Ramp Time has expired and UTS is not achieved, the SMC-50 controller will hold the current limit until UTS is reached, a Motor Overload Trip, or Starter Overtemp Fault occurs. Kickstart is also available with current limit.

[Figure 59](#) provides a graphical depiction of a Current Limit Start. [Table 11](#) provides a list of Current Limit Start parameters.

Figure 59 - Current Limit Start Timing Diagram

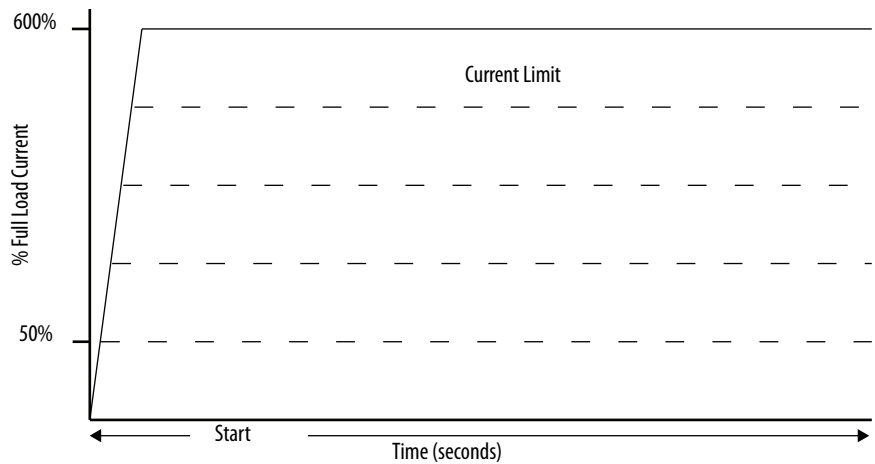

Table 11 - Current Limit Start Parameter List

Parameter Number	Parameter Name	Minimum/Maximum Values	Default Value	Access	Units
50	Ramp Time	0.0...1000.0	10.0	R/W	SEC
53	Cur Limit Level	50...600	350		%FLC
54	Kickstart Time	0.0...2.0	0.0		SEC
55	Kickstart Level	0.0...90	0.0		%LRT
182	Start Delay	0.0...30	0.0		SEC
186	UTS Level	0.0...100	75		%
78	Motor FLC	1.0...2200.0	1.0		Amps

Full Voltage Start

Set Starting Mode (Parameter 49) = Full Voltage.

This starting mode is used for applications requiring across-the-line starting. The controller supplied voltage to the motor will reach full voltage within five AC line cycles (0.08 s at 60 Hz and 0.1 s at 50 Hz).

Figure 60 - Full Voltage Start Timing Diagram

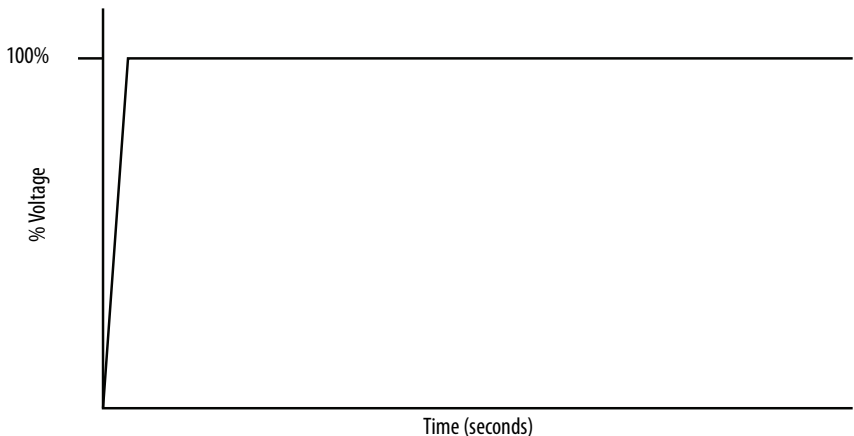

Torque Control Start

Set Starting Mode (Parameter 49) = Torque Ramp.

This motor starting method provides a torque ramp from an initial starting torque level to a maximum torque level over the start time. The torque levels are entered in percent of rated motor torque. This requires that the Rated Torque parameter be configured to the motor's rated torque. The torque start operating mode requires motor tuning to function properly. Tuning can be forced manually or it will otherwise be performed automatically the first time the motor is started. See [Motor Tuning on page 75](#).

Figure 61 - Torque Control Start Timing Diagram

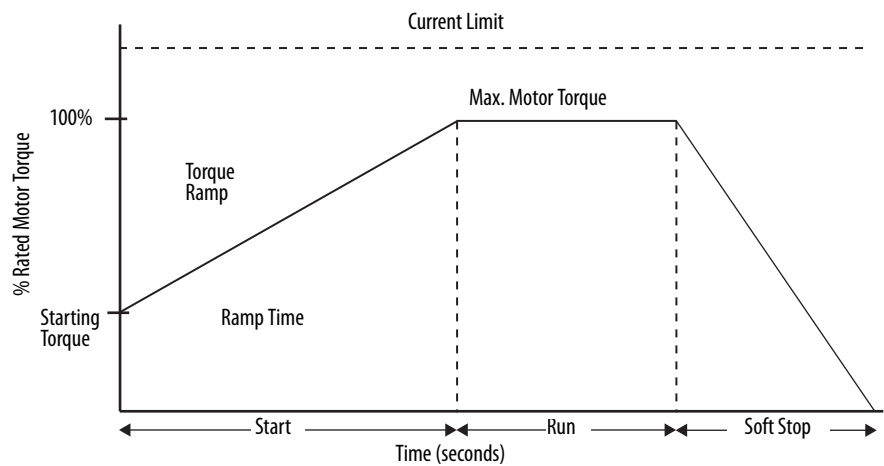

[Table 12](#) provides a list of Torque Control Start parameters.

Table 12 - Torque Start Mode Parameter List

Parameter Number	Parameter Name	Minimum/Maximum Values	Default Value	Access	Units
305	Starting Torque	0...300	100	R/W	%
52	Max Torque	0...300	250		%
50	Ramp Time	0.0...1000.0	10.0		SEC
47	Rated Torque	0...10000	10		N·m
48	Rated Speed	750, 900, 1500, 1800, 3600	1800		rpm
53	Cur Limit Level	50...600	350		%FLC
54	Kickstart Time	0.0...2.0	0.0		SEC
55	Kickstart Level	0.0...90	0.0		%LRT
78	Motor FLC	1.0...2200.0	1.0	A	

Pump Control Start and Stop

Set Starting Mode (Parameter 49) = Pump Start.
Set Stop Mode (Parameter 65) = Pump Stop.

This control mode helps to reduce surges (fluid hammer) during the starting and stopping of a centrifugal pump by smoothly accelerating and decelerating the motor. As such, starting and stopping parameters are typically configured together. The microprocessor analyzes the motor variables and generates commands that control the motor and reduce the possibility of surges occurring in the system.

The starting time (Ramp Time, Parameter 50) is programmable from 0.0...1000.0 seconds and the stopping time (Stop Time, Parameter 66) is programmable from 0...999 seconds when the Pump Stop mode is selected from Parameter 65.



ATTENTION: Pump stopping is not intended to be used as an emergency stop. See the applicable standard for emergency stop requirements.



ATTENTION: Pump stopping may cause motor heating depending on the mechanical dynamics of the pumping system. Therefore, select the lowest stopping time setting that will satisfactorily stop the pump.

Figure 62 - Pump Control Mode Timing Diagram

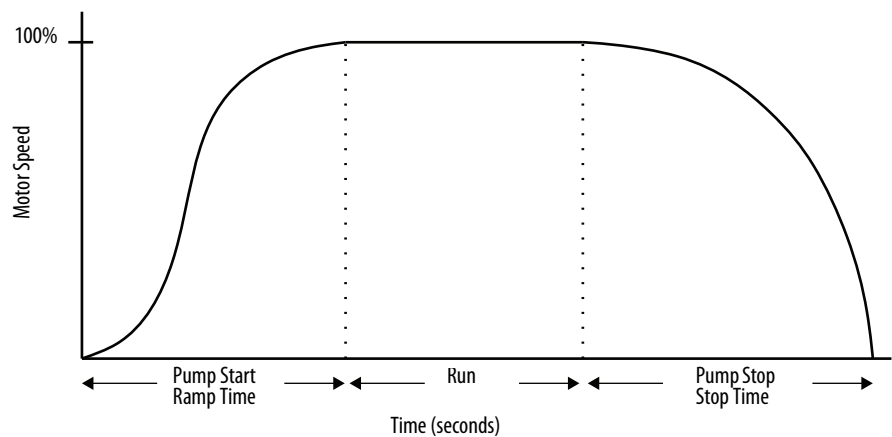

Table 13 - Pump Start Control Mode Parameter List

Parameter Number	Parameter Name	Minimum/Maximum Values	Default Value	Access	Units
50	Ramp Time	0.0...1000.0	10.0	R/W	SEC
51	Initial Torque	0...90	70		%LRT
67	Backspin Timer	0...999	0		SEC
54	Kickstart Time	0.0...2.0	0.0		SEC
55	Kickstart Level	0.0...90	0.0		%LRT
78	Motor FLC	1.0...2200.0	1.0		Amps

Table 14 - Pump Stop Mode Parameter List

Parameter Number	Parameter Name	Minimum/Maximum Values	Default Value	Access	Units
66	Stop Time	0.0...999.0	0.0	R/W	SEC
68	Pump Pedestal	0.0...50.0	0.0		%

TIP Pump Pedestal, Parameter 68, lets you modify the internal pump control algorithm for special application conditions.

For example, if overload trips persist during stopping, either reduce the Stop Time, Parameter 66, or increase the Pump Pedestal in 5% increments. Try not to exceed 40%

Additional Start Features— Dual Ramp Start Functions

This feature is useful for applications that have varying loads (and therefore varying starting feature requirements). Dual Ramp lets you select between two separate start profiles with separately adjustable ramp times, initial torque settings, etc. to best meet the application needs.

The second start profile is enabled by configuring one of the controller auxiliary inputs to Dual Ramp and activating that input. When the Start command is then activated, the second start profile will begin.

Figure 63 - Dual Ramp Start Timing Diagram

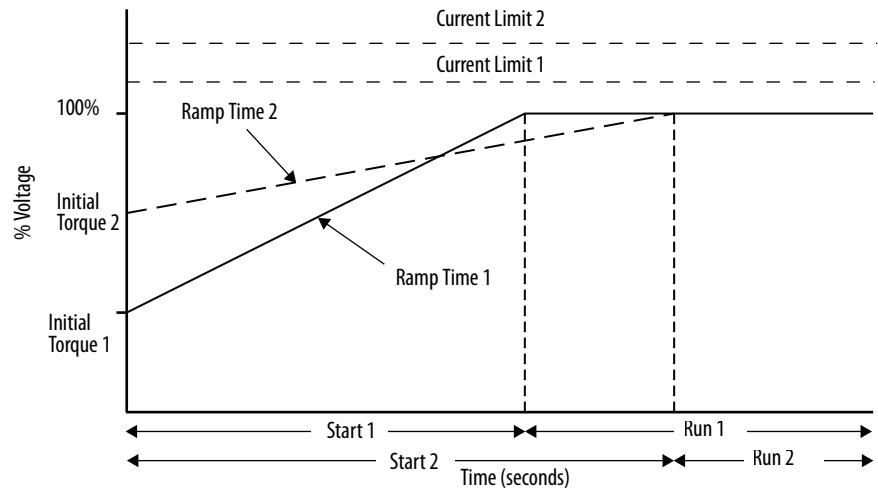

Table 15 - Dual Ramp Start Mode Parameter List

Parameter Number	Parameter Name	Minimum/Maximum Values	Default Value	Access	Units
49	Starting Mode	Full Voltage, Current Limit, Soft Start, Linear Speed, Torque Ramp, Pump Start	Soft Start	R/W	
50	Ramp Time	0.0...1000.0	10.0		SEC
51	Initial Torque	0...90	70		%LRT
52	Max Torque	0...300	250		%
53	Cur Limit Level	50-600	350		%FLC
54	Kickstart Time	0.0...2.0	0.0		SEC
55	Kickstart Level	0.0...90	0.0		%LRT
305	Starting Torque	0...300	100		%
58	Starting Mode 2	Full Voltage, Current Limit, Soft Start, Linear Speed, Torque Ramp, Pump Start	Soft Start		
59	Ramp Time 2	0.0...1000.0	10.0		SEC
60	Initial Torque 2	0...90	70		%LRT
61	Max Torque 2	0...300	250		%
62	Cur Limit Level 2	50...600	350		%FLC
63	Kickstart Time 2	0.0...2.0	0.0		SEC
64	Kickstart Level 2	0...90	0.0	%LRT	
306	Starting Torque 2	0...300	100	%	
182	Start Delay	0...30	0	SEC	

Start Timer (Start Delay)

This feature lets you set a user-configurable start (0...30 s) delay from the point when the start command is enabled until the start sequence actually occurs. This feature applies to any start mode.

Timed Start

Timed Start, Parameter 183, forces the starting profile to complete the entire user-configured ramp time before applying full voltage. In some starting modes (for example, soft start) and with certain loads (for example, lightly loaded motor), an early UTS condition can be generated placing the SMC-50 controller in full-voltage start, which might cause excessive current. Setting Timed Start to "Enable" forces all starts to complete the configured Ramp Time, Parameter 50.

Backspin Timer

A Backspin Timer, Parameter 67, is provided in order to avoid starting a motor into a backspin condition, which may result in motor shaft damage. The user-configured time begins to count down after a stop maneuver is complete. All start inputs are ignored until the backspin timer has timed out.

Motor Winding Heater Function

The Motor Winding Heater function provides low levels of current to each of the motor windings to preheat a cold motor before starting. To avoid thermally stressing a single motor winding, the SMC-50 controller cycles the heating current to each of the phases. This feature provides a programmable heating level, heating time, and a control (terminal block) input which can be used to start the process.

TIP Configuration of control module inputs is done via Input 1, Parameter 56, or Input 2, Parameter 57. If a 150-SM4 Optional Digital I/O Module is configured, its inputs can also be used for the motor winding heater function.

Table 16 - Motor Winding Heater Parameter List

Parameter Number	Parameter Name	Minimum/Maximum Values	Default Value	Access	Units
220	Heating Time	0...1000	0	R/W	SEC
221	Heating Level	0...100	0		%

The motor winding heater function can be activated after a valid start command is received. After a valid start, the activation of the heating function can be performed by:

- programming the Heating Time, Parameter 220, to a non-zero value or
- configuring an input to "Motor Heater" and activating that input prior to the start command.

The heater function continues for the specified time or until the input is deactivated, at which time the motor starts. The heater function is disabled if the:

- Heating Level, Parameter 221, is set to zero, or
- Heating Time, Parameter 220, is set to zero, or
- input is inactive (or not configured) at the time of the start command.

Stopping Modes

Overview

Stop Mode, Parameter 65, defines the type of stop maneuver performed by the SMC-50 controller when a stop command is issued. The STOP command can be initiated through any input⁽¹⁾, a network command, or the JOG key on the A6 HIM.

TIP The STOP Key on a Cat. no. 20-HIM-A6 or 20-HIM-C6S device initiates a Coast-to-Stop.

The available stopping modes are:

- Coast-to-Stop
- Soft Stop
- Linear Speed Deceleration
- SMB Smart Motor Braking
- Pump Stop
- External Brake

Coast-to-Stop

Set Starting Mode (Parameter 49) = Coast. This is the factory default value.

When Stop Mode, Parameter 65, is set to Coast-to-Stop and the STOP command is initiated, the starter will not perform any other function and the motor coasts to a stop. No other Stop parameters need to be configured if Coast-to-Stop is enabled.

The Coast-to-Stop command overrides all other commands that could result in motor operation. When this command is initiated, it is latched into the controller's logic so that no other motor command can occur until it is cleared. It is cleared when all terminal block Start inputs are opened and any other Soft Stop (Inhibits a Start) input is removed. Note that in a 2-wire control scheme, this involves placing the Start/Stop input in the Stop position; in a 3-wire control scheme, this involves opening the Start input.

(1) To use terminal block inputs to initiate a Stop Mode, configure the respective input for Start/Stop or Stop Option.

Soft Stop

Set Stop Mode (Parameter 65) = Soft Stop.

The Soft Stop feature can be used in applications that require an extended stop time. The voltage ramp down time is user-adjustable from 0...999 seconds using Stop Time, Parameter 66. The load will stop when the SMC-50 controller output voltage drops to a point where the load torque is greater than the developed motor torque.



ATTENTION: Soft Stop is not intended to be used as an emergency stop. See the applicable standards for emergency stop requirements.

Figure 64 - Soft Stop

Figure 65 - Soft Stop Timing Diagram

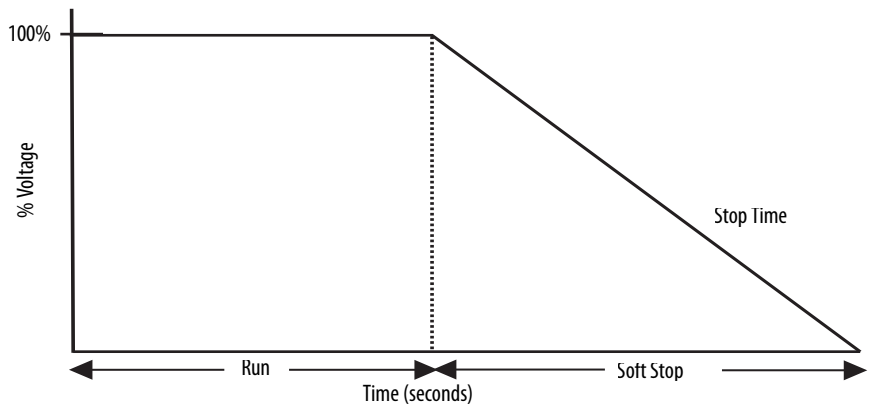

Table 17 - Soft Stop Mode Parameter List

Parameter Number	Parameter Name	Minimum/Maximum Values	Default Value	Access	Units
66	Stop Time	0...999	0	R/W	SECS

TIP For additional details, see [Figure 72 on page 99](#)

Linear Speed (Linear Deceleration)

Set Stop Mode (Parameter 65) = Linear Speed.

When Stop Mode, Parameter 65, is configured for Linear Speed, the SMC-50 controller will stop the motor following a timed linear speed ramp configured in Stop Time, Parameter 66. A current limit setting is also available to limit the current while stopping. If the current limit level is reached, the motor will decelerate faster than the defined ramp. If motor current falls below the current limit, the ramp is resumed.



ATTENTION: Linear Stop is not intended to be used as an emergency stop. See the applicable standards for emergency stop requirements.

Figure 66 - Linear Speed Deceleration Timing Diagram

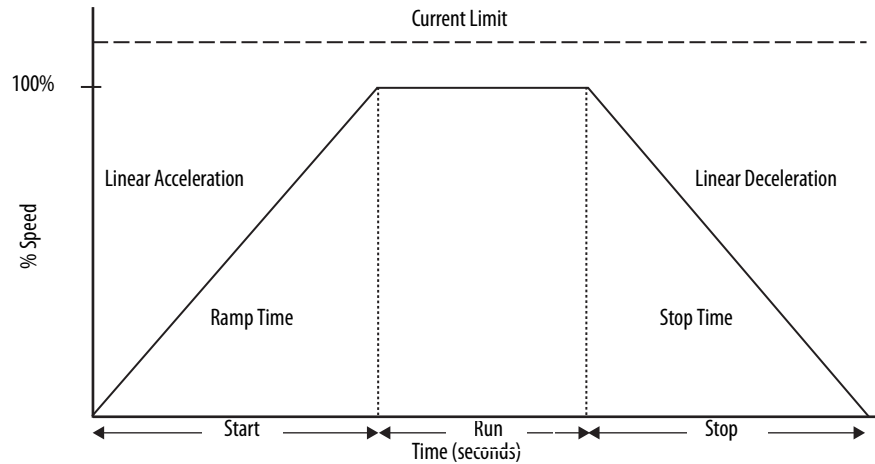

Table 18 - Linear Deceleration Mode Parameter List

Parameter Number	Parameter Name	Minimum/Maximum Values	Default Value	Access	Units
66	Stop Time	0.0...999	0.0	R/W	SEC
53	Cur Limit Level	50...600	350		%FLC

For additional details, see [Figure 72 on page 99](#).

Smart Motor Braking (SMB)

Set Stop Mode (Parameter 65) = SMB.

When Stop Mode, Parameter 65, is configured for SMB and the Stop Maneuver is commanded, the SMC-50 controller will apply the configured braking current and brake the motor to a stop. This function can be used in applications that require reduced stopping times. The SMC-50 incorporates a microprocessor-based system that applies braking current to the motor without any additional equipment. This option offers a user-adjustable braking current setting from 0% to 400% of the motor's full load current rating using Braking Current, Parameter 69. Further, it provides automatic brake current shut-off at zero speed detection.



ATTENTION: Smart Motor Braking is not intended to be used as an emergency stop. See applicable standards for emergency stop requirements.

Figure 67 - SMB Timing Diagram

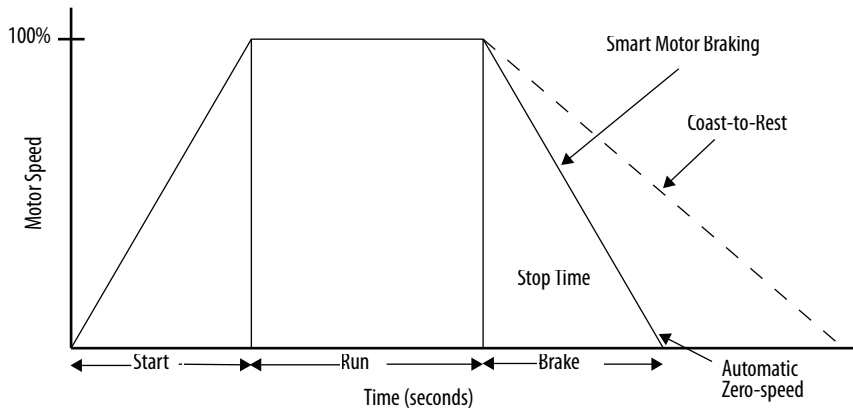

Table 19 - SMB Mode Parameter List

Parameter Number	Parameter Name	Minimum/Maximum Values	Default Value	Access	Units
66	Stop Time ^{(1) (2)}	0 .. 999	0	R/W	SECS
69	Braking Current	0 .. 400	0		%FLC

- (1) You do not need to program a Stop Time when you are using SMB. SMB automatically controls the duration (Stop Time) of the braking current to the motor from the Running at Speed condition until a zero speed condition (Zero Speed Braking Shut Off feature/function). Programming a Stop Time overrides the SMB Zero Speed Braking Shutoff feature/function. This could result in current being applied to a stopped motor, which causes the motor to overheat.
- (2) With Stop Time, Parameter 66, set to a non-zero time value, the user-selected "Braking Current", Parameter 69, is applied for the user-configured "Stop Time" regardless of the motor speed (for example, Automatic Zero Speed Detection disabled). You can use this braking method in applications where detecting zero speed is ineffective or when braking the motor to a complete stop results in random overload trips. Note that an ideal Stop Time setting can be accomplished by trial and error, but should always allow for some coast time. Setting the Stop Time for too long of a time period can result in braking current to be applied to a stopped motor and will likely result in overload trips.

Preset Slow Speed and Slow Speed with Braking

The Slow Speed Mode can be used in applications that require a jog for general-purpose positioning. Preset Slow Speed 1, Parameter 72, and Preset Slow Speed 2, Parameter 350, provide operation from +1...+15% forward or -1...-15% reverse of the motor base speed.

You must configure an SMC-50 controller control input for Slow Speed to initiate a slow speed operation. You must configure a second input for Coast or Stop Option. User parameters 56 and 57.

The Slow Speed operating mode requires motor tuning to function properly. Tuning can be forced manually or it will otherwise be performed automatically the first time the motor is started. See [Motor Tuning on page 75](#).

To provide more precise stopping from a slow speed operation, braking from slow speed can also be configured using Slow Brake Current, Parameter 73. The maximum allowable brake current is 350% FLC. A value of 0 (default) applies no braking and a motor coast-to-stop results and slow speed is terminated.



ATTENTION: Slow speed running is not intended for continuous operation due to reduced motor cooling.

Figure 68 - Preset Slow Speed Timing Diagram

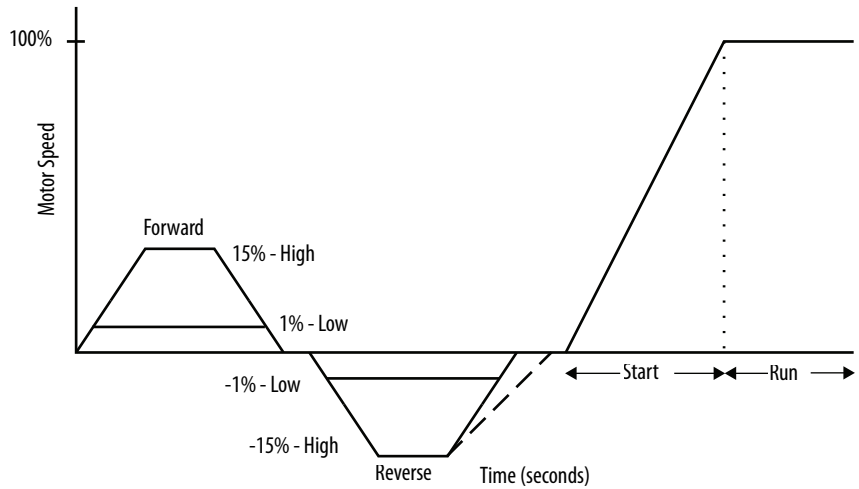

Table 20 - Preset Slow Speed and Slow Speed with Braking Parameter List

Parameter Number	Parameter Name	Minimum/Maximum Values	Default Value	Access	Units
56	Input 1	0...14	4 (Stop option)	R/W	—
57	Input 2	0...14	0 (Disable)		—
72	Slow Speed 1	-15...+15 ⁽¹⁾	+10 ⁽¹⁾		%
73	Slow Brake Cur	0...350 ⁽²⁾	0 ⁽²⁾		%FLC
350	Slow Speed 2	-15...+15 ⁽¹⁾	+10 ⁽¹⁾		%

(1) Direction of the motor rotation is dependent on the sign (\pm) of Slow Speed %.
 (2) With Slow Brake Cur, Parameter 73, set to 0 (default), the motor coasts-to-stop from Slow Speed. When the value is between 1...350, braking current is applied from Slow Speed.

Accu-Stop™

This function combines the benefits of the SMB and Preset Slow Speed features. For general-purpose positioning, the Accu-Stop function provides a brake from full speed to the preset slow speed setting, then a brake or coast-to-stop.

The Accu-Stop function is enabled whenever the Stop Mode, Parameter 65, is configured for SMB and:

- a control input is configured for Stop
- a control input is configured for Start
- a control input is configured for Slow Speed.

With the above SMC-50 controller control configuration and with the motor running, enabling the Slow Speed input initiates an SMB to the configured Slow

Speed percent value, Parameter 72. The SMC-50 controller continues to run the motor in slow speed until the Slow Speed input is disabled. At that point, the motor either brakes to stop or coasts to stop, depending on the value of the Slow Brake Cur, Parameter 73. If the value of Slow Brake Cur is zero (0), the motor coasts to stop from Slow Speed. If the value of Slow Brake Cur is a value other than zero, the SMC-50 controller uses braking to stop the motor using that value as a percent of the Motor FLC. See [Figure 69](#), [Figure 76](#) and [Table 21](#).

The Accu-Stop operating mode requires motor tuning to function properly. Tuning can be forced manually or it will otherwise be performed automatically the first time the motor is started. See [Motor Tuning on page 75](#).



ATTENTION: Accu-Stop is not intended to be used as an Emergency Stop. See applicable standards for emergency stop requirements.

Figure 69 - Accu-Stop Timing Diagram

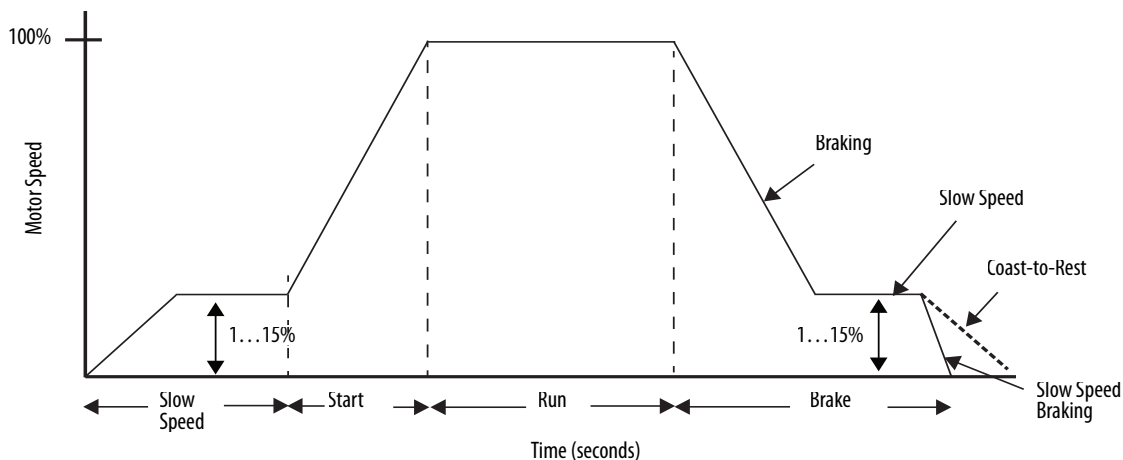

Table 21 - Accu-Stop Mode Parameter List

Parameter Number	Parameter Name	Minimum/Maximum Values	Default Value	Access	Units
65	Stop Mode	SMB	Coast	R/W	
66	Stop Time ⁽¹⁾⁽²⁾	0...999	0		SECS
69	Braking Current	0...400	0		%FLC
72	Slow Speed ⁽³⁾	-15...+15	+10		%
73	Slow Brake Cur ⁽⁴⁾	0...350	0		%FLC

- (1) You do not need to program a Stop Time when you are using SMB. SMB automatically controls the duration (Stop Time) of the braking current to the motor from the Running at Speed condition until a zero speed condition (Zero Speed Braking Shut Off feature/function). Programming a Stop Time overrides the SMB Zero Speed Braking Shut off feature/function. This could result in current being applied to a stopped motor, which causes the motor to overheat.
- (2) With Stop Time, Parameter 66, set to a non-zero time value, the user-selected "Braking Current", Parameter 69, is applied for the user-configured "Stop Time" regardless of the motor speed (for example, Automatic Zero Speed Detection disabled). You can use this braking method in applications where detecting zero speed is ineffective or when braking the motor to a complete stop results in random overload trips. Note that an ideal Stop Time setting can be accomplished by trial and error, but should always allow for some coast time. Setting the Stop Time for too long of a time period can result in braking current to be applied to a stopped motor and will likely result in overload trips.
- (3) Direction of the motor rotation is dependent on the sign (±) of Slow Speed.

- (4) With Slow Brake Cur, Parameter 73, set to 0 (default), the motor coasts-to-stop from Slow Speed. When the value is between 1...350, braking current is applied from Slow Speed.

External Braking Control

Set Stop Mode (Parameter 65) = External Brake.

The external braking control feature enables an external mechanical motor brake to function in concert with the SMC-50 controller stop parameter. When the Stop Mode, Parameter 65, is set to Ext Brake and the stop maneuver is commanded, the starter will remove power to the motor and close any auxiliary output configured for External Brake. The auxiliary output relay configured for External Brake⁽¹⁾ will remain active for the user-configured Stop Time, Parameter 66. Once the Stop Time is complete, the unit will open the auxiliary output and switch to the stopped state. While in the External Brake stopped mode, all relays and status functions will operate as they would in any other mode.

Table 22 - External Braking Control Mode Parameter List

Parameter Number	Parameter Name	Minimum/Maximum Values	Default Value	Access	Units
66	Stop Time	0...999	0	R/W	SECS

Running Modes

Internal Bypass Modes

The unit will run under SCR control mode when it starts and stops a motor. When the motor is up to speed, the internal bypass contactor(s) close. Motor current then flows through the contactor(s) and not through the SCRs.

Solid-state (SCR) Control Mode

The unit will run at full voltage under SCR control mode when the unit is at full speed and when no external bypass contactor is provided. All SMC-50 controller diagnostic and power monitoring features are available in this running mode.

External Bypass Control Mode

An external bypass contactor may be configured to operate the motor while running at full voltage and speed. The SMC-50 controller controls the external bypass contactor by using one of the auxiliary relay outputs configured to Ext. Bypass using that output's configuration parameter.

(1) The appropriate auxiliary relay must be configured for the Ext. Brake stopping function using the Aux X relay configuration parameter (for example, Aux 1:Parameter 172, Aux 2: Parameter 176)

Devices rated 90...180 A

In external bypass control mode on devices rated 90...180 A, the controller's integral current sensors are out of the control circuit. If all the current sensing features (including motor overload) are desired while running in external bypass control mode, then the optional PTC/Ground Fault/External Current Transformer Expansion Module (150-SM2) and an 825-MCM180 current sensor are required. See [Figure 111 on page 286](#) and [Figure 42 on page 64](#).

Devices rated 210...520 A

In external bypass control mode on devices rated 210...520 A, the controller's integral current sensors remain in the control circuit by using Cat. No. 150-SCBK (devices rated 210...320 A) or Cat. No. 150-SDBK (devices rated 361...520 A) Bypass Kits. See [Figure 70 on page 96](#). The optional PTC/Ground Fault/External Current Transformer Expansion Module (150-SM2) and an 825-MCM20 with user supplied CTs with 5 A secondary can be used in place of the bypass kits. See [Figure 109 on page 284](#) and [Figure 42 on page 64](#).

TIP When using the Cat. No. 150-SCBK or 150-SDBK bypass kit, the controller firmware must be FRN 3.001 or higher.

The Cat. No. 150-SM2 Expansion Module can only be inserted into control module expansion port 7 or 8. In addition, only one 150-SM2 Expansion Module can be used per control module. Once the 150-SM2 Expansion Module is installed in the control module and power is applied, it must be configured using the 20-HIM-A6, the 20-HIM-C6S, or PC software (for example, Connected Components Workbench software). For additional configuration details refer to [Chapter 2](#), and [Chapter 6](#).

Figure 70 - Wiring Diagram for Frame C (Cat. No. 150-SC...) or Frame D (Cat. No. 150-SD...) Devices with Bypass Contactor and Bypass Bus Kit

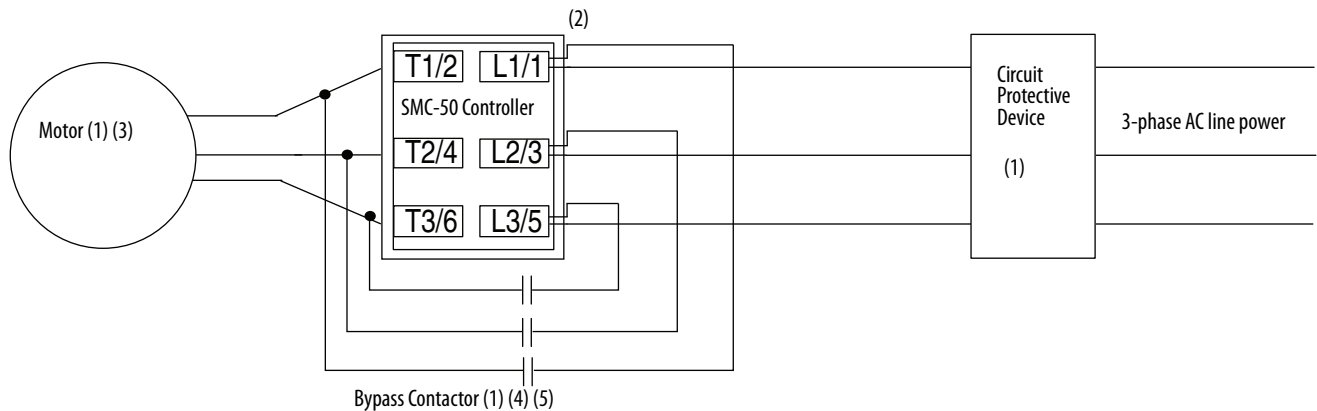

- (1) Customer supplied.
- (2) SMC-50 controller Bypass bus kit Cat. No. 150-SCBK (Frame C; Cat. No. 150-SC...) or 150-SDBK (Frame D; Cat. No. 150-SD...).
- NOTE:** Controller FRN 3.001 or higher is required.
- (3) Due to current leakage through an SCR in the OFF state (controller stopped), some form of upstream line power isolation is recommended if maintenance is required on the motor. See the Isolation Contactor Applications for details.
- (4) Bypass must be controlled by an auxiliary contact of the SMC-50 controller that is configured for external bypass.

(5) In North America, size the bypass contactor per the motor Hp and FLA. In IEC applications, size the bypass contactor per the motor AC-1 rating. The short-circuit rating of the bypass contactor must be similar to that of the SMC-50 controller.

NOTE: In addition to a small amount of leakage current flowing through an SCR in the off-state, failure of one or more solid-state power switching components allows uncontrolled current to flow to the winding(s) of the motor. This could potentially result in overheating or damage to the motor. To prevent potential personal injury or equipment damage, the installation of an isolation contactor or shunt trip-type circuit breaker capable of interrupting the motor's locked rotor current on the line side of the SMC-50 controller is recommended. Operation of the isolation device should be coordinated using one of the SMC-50 controller auxiliary contacts configured to NORMAL.

External Overload (all devices)

The SMC-50 controller can also be used with an external overload in conjunction with the external bypass. In this configuration the external bypass contactor must be fully rated to the motor Hp/kW and FLA. See [Figure 71 on page 97](#).

Figure 71 - Wiring Diagram with Bypass Contactor and External Overload

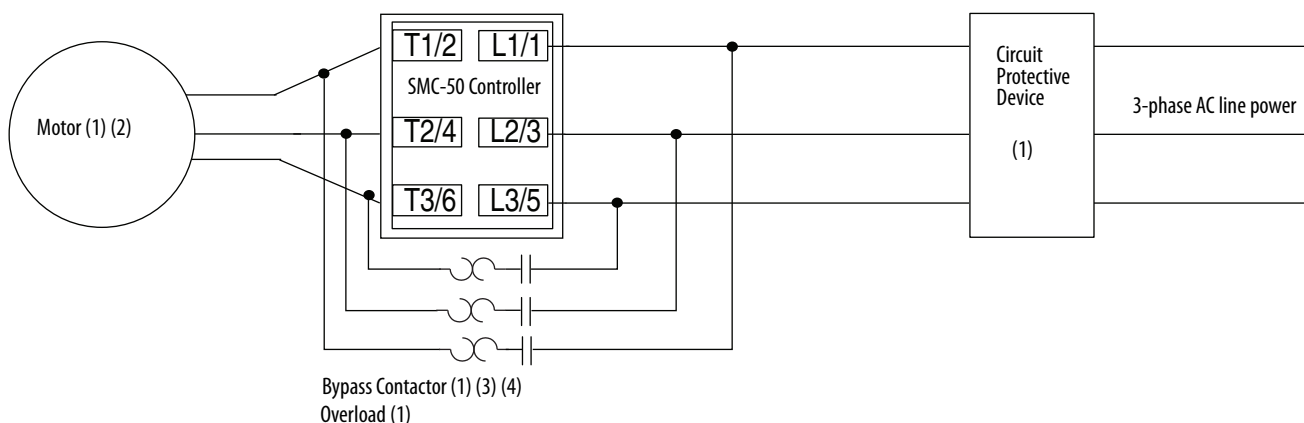

(1) Customer supplied.

(2) Due to current leakage through an SCR in the OFF state (controller stopped), some form of upstream line power isolation is recommended if maintenance is required on the motor. See the Isolation Contactor Applications for details.

(3) Bypass must be controlled by an auxiliary contact of the SMC-50 controller that is configured for external bypass.

(4) Bypass contactor must be fully rated to motor Hp/kW and FLA.

NOTE: In addition to a small amount of leakage current flowing through an SCR in the off-state, failure of one or more solid-state power switching components allows uncontrolled current to flow to the winding(s) of the motor. This could potentially result in overheating or damage to the motor. To prevent potential personal injury or equipment damage, the installation of an isolation contactor or shunt trip-type circuit breaker capable of interrupting the motor's locked rotor current on the line side of the SMC-50 controller is recommended. Operation of the isolation device should be coordinated using one of the SMC-50 controller auxiliary contacts configured to NORMAL.

Energy Saver Mode

The energy saver function only applies during light motor load situations at which time the SMC-50 controller reduces current to the motor and thereby saves energy.

When in energy saver operation, the Energy Savings status bit is set. In addition, Energy Savings, Parameter 15, indicates the percentage energy savings.

Parameter 17 - [Power Factor] should be monitored and recorded when the motor is running at no/light load and at full/heavy load. The power factor value

where the controller enters Energy Saver mode is determined by setting **Parameter 193 - [Energy Saver]** to a value between the no/light load and full/heavy load recorded values.

Table 23 - Energy Saver Mode Parameter List

Parameter Number	Parameter Name	Minimum/Maximum Values	Default Value	Access	Units
15	Energy Savings	0...100	0	R	%
17	Power Factor	-1.00...1.00	0	R	—
193	Energy Saver	0.00...1.00	0.00	R/W	—

NOTE: Set Parameter 193=0 to disable Energy Saver mode.

Emergency RUN

With the SMC-50 controller, a control terminal or network (via Comm Control Word) input can be configured as the Emergency Run command input. All faults are disabled when this input is active.

NOTE: The Emergency Run command input does not actually start the unit, but causes the unit to run in the Emergency Run mode. The Emergency Run command can be initiated at any time. This command is not latched allowing the Emergency Run mode to be cancelled while the unit is still running.

Sequence of Operation

[Figure 72](#) through [Figure 77](#) show the different operation sequences for the Soft Stop, Preset Slow Speed, Pump Control, SMB Smart Motor Braking, Accu-Stop, and Slow Speed with Braking options.

When control power is present but 3-phase line power is not applied, a valid START command causes AUX contacts configured for "Normal" to close. While waiting for 3-phase line power, the SMC-50 controller will indicate "Starting". The start sequence is initiated when 3-phase line power is applied.



ATTENTION: You are responsible for determining which stopping mode is best suited to the application and will meet applicable standards for operator safety on a particular machine.



ATTENTION: Stopping modes are NOT intended to be used as an emergency stop. See applicable standards for emergency stop requirements.



ATTENTION: The Energy Savings setting is motor and load dependent. Setting this to high may cause the unit to enter energy savings to soon and increase current.

Figure 72 - Soft Stop

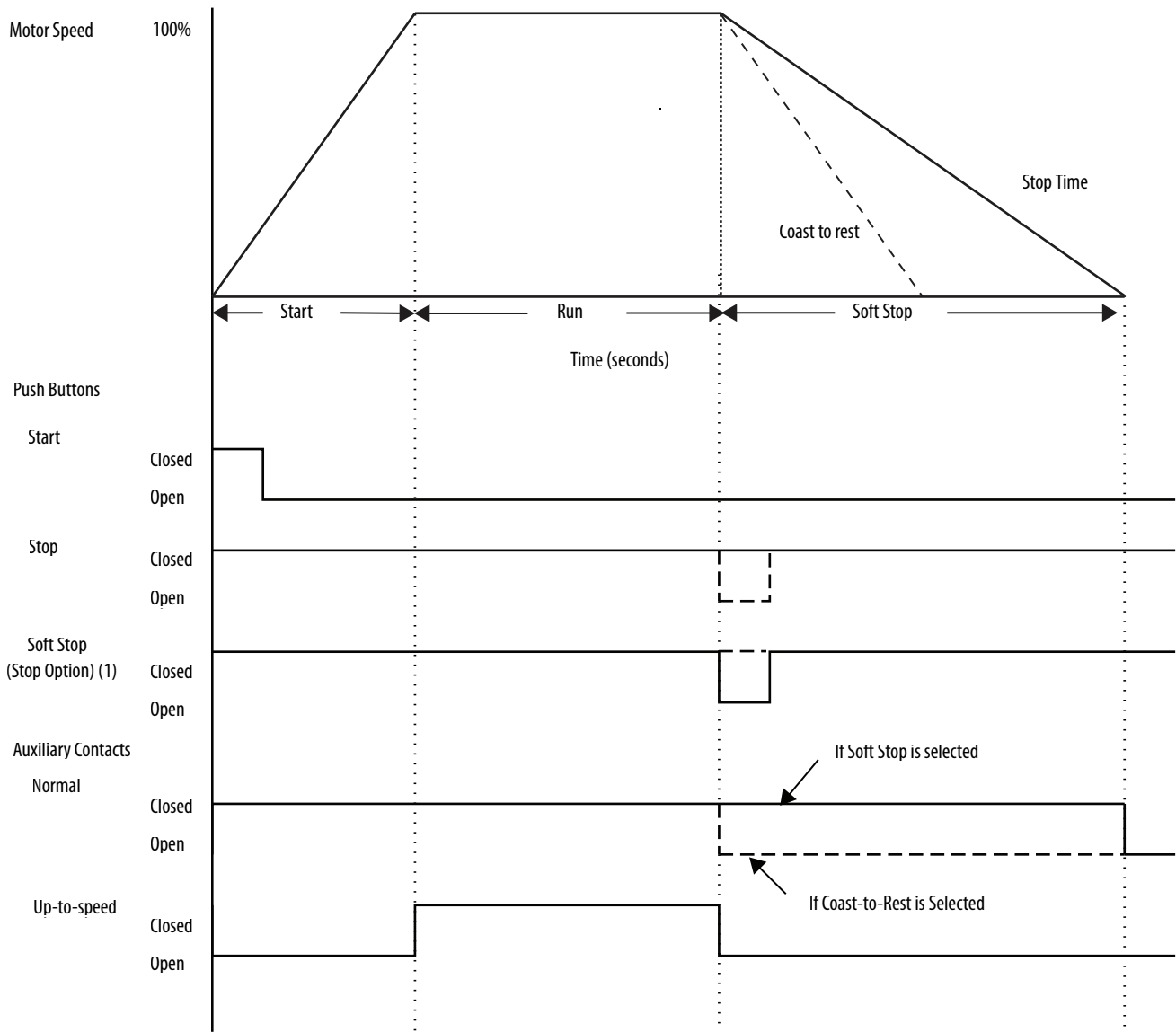

(1) When the Stop Mode, Parameter 65, configured for Soft Stop and with the Input push button configured for the Stop Option

Figure 73 - Preset Slow Speed

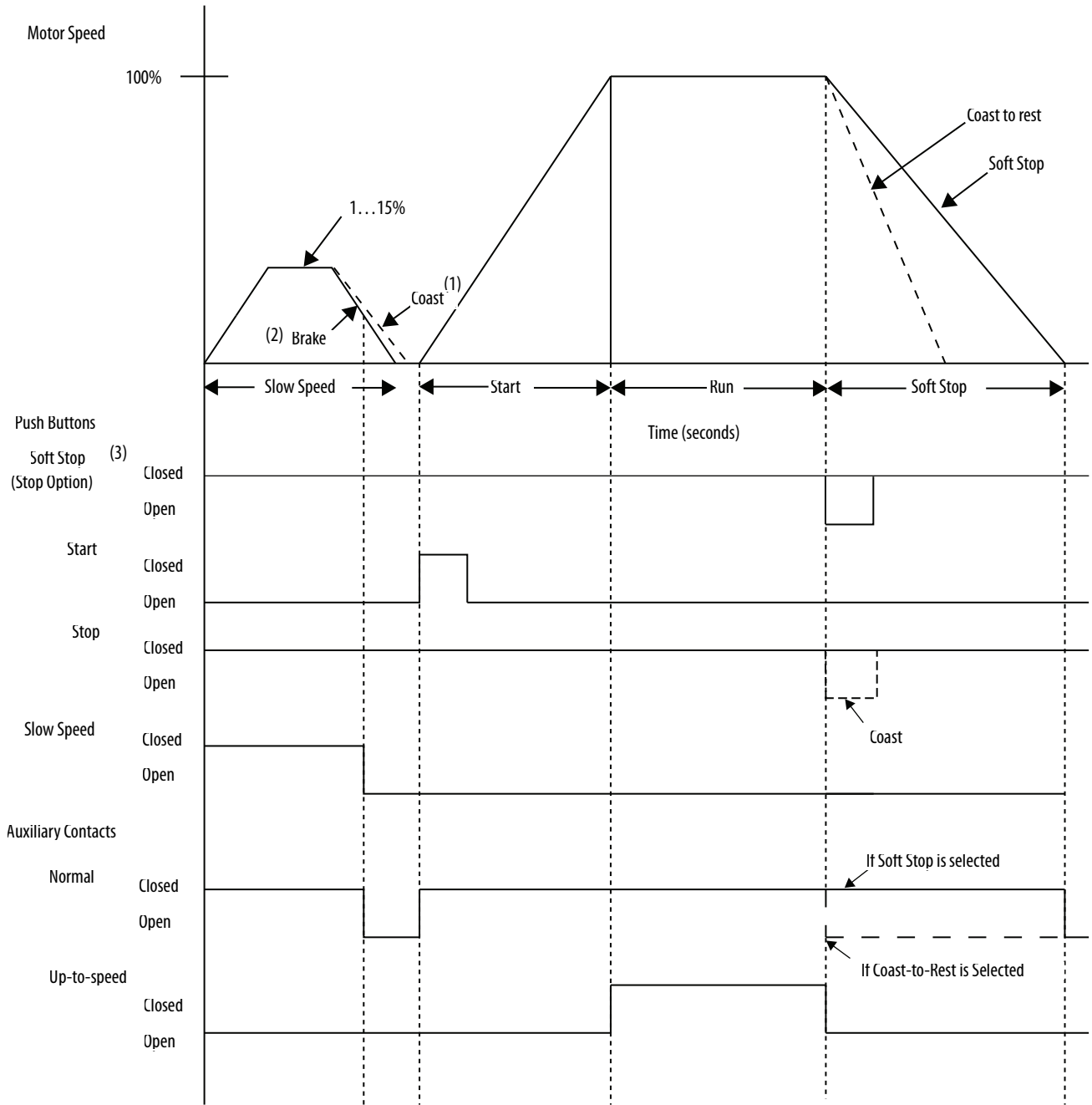

- (1) Coast if Slow Brake Cur Parameter = 0.
- (2) Brake if Slow Brake Cur Parameter >0 and <350.
- (3) When the Stop Mode, Parameter 65, configured for Soft Stop and with the Input push button configured for the Stop Option.

Figure 74 - Pump Control

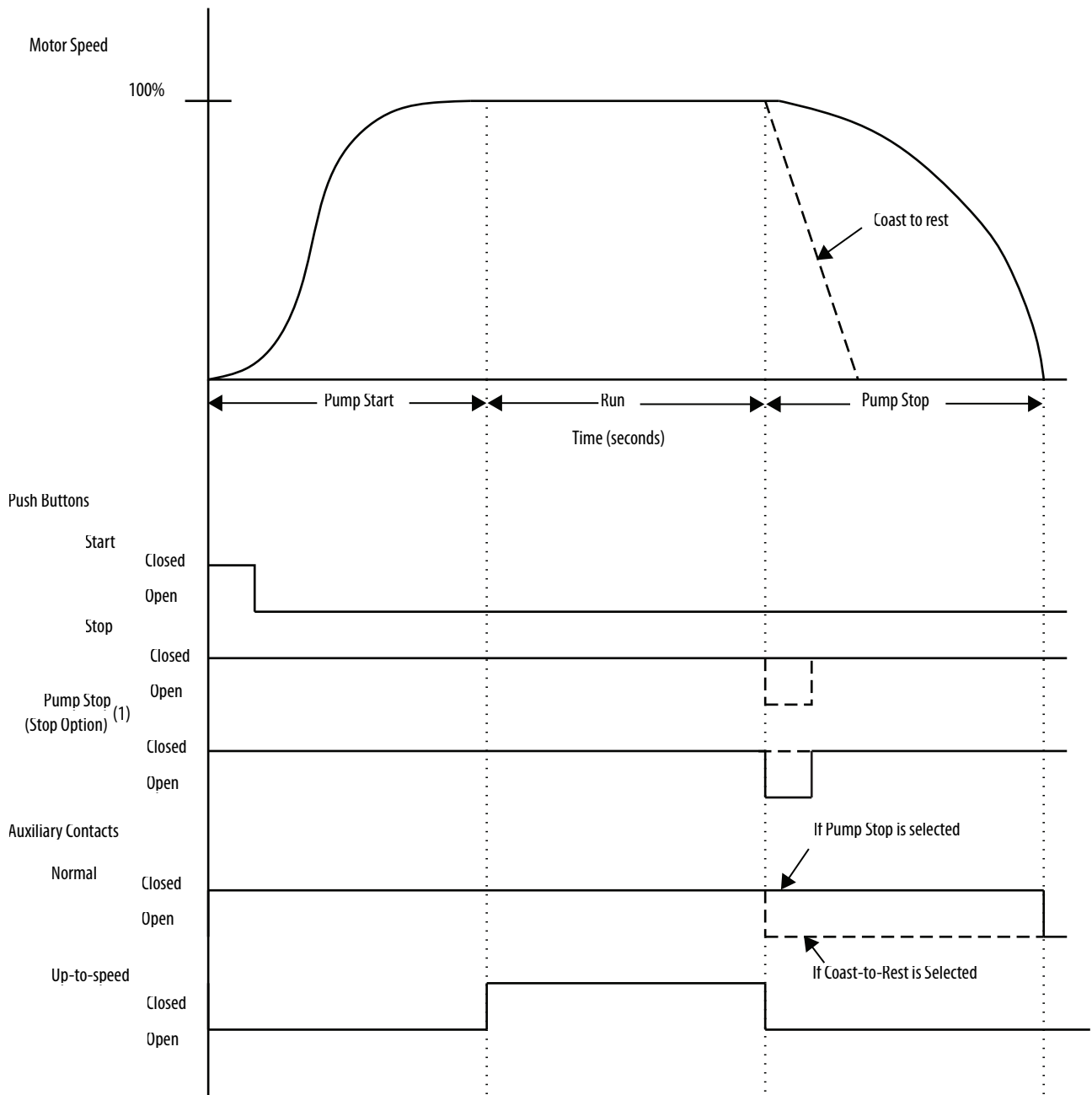

(1) When Stop Mode, Parameter 65, is configured for Pump Stop and the Input push button is configured for Stop Option.

Figure 75 - Smart Motor Braking (SMB)

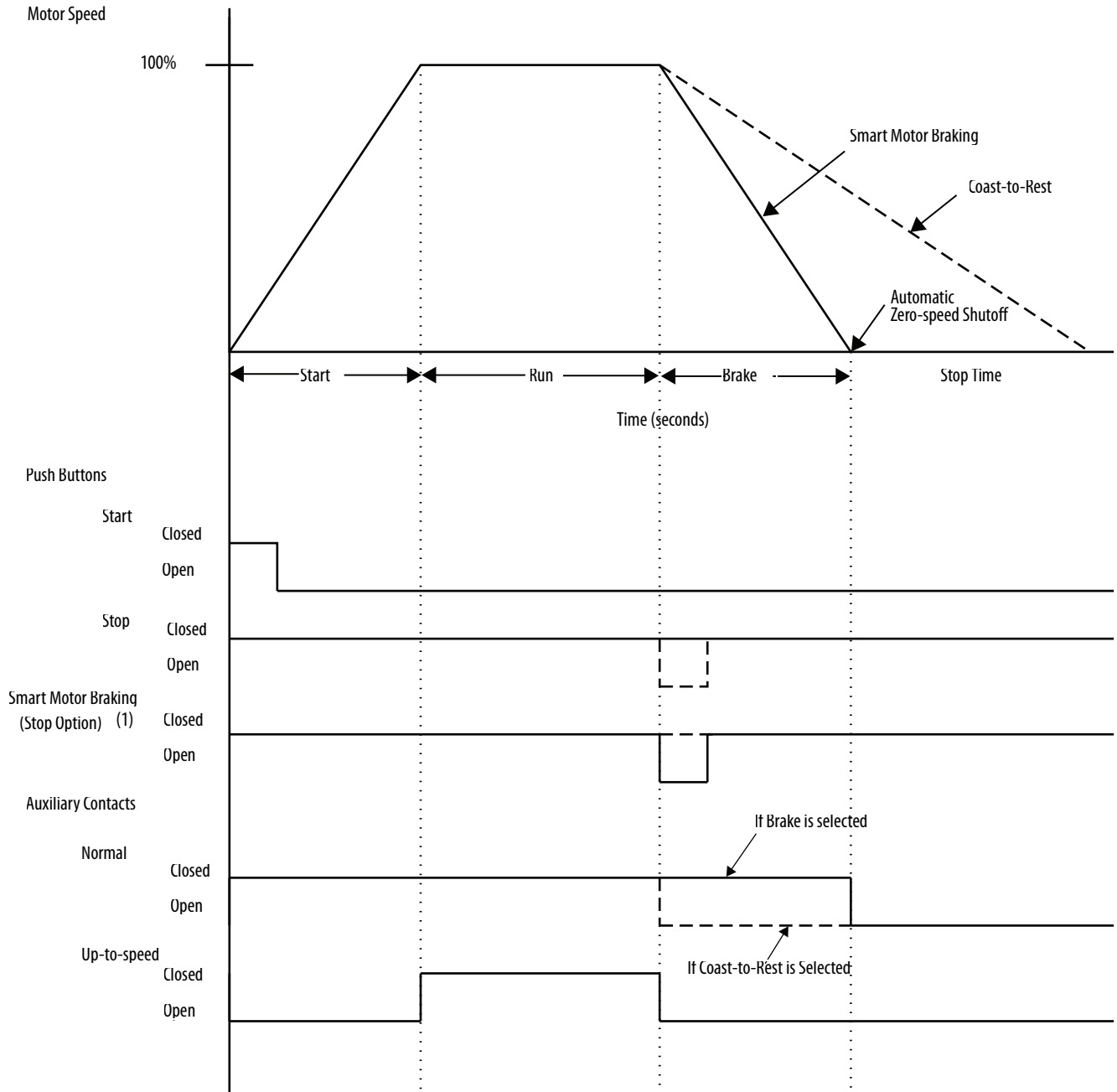

1) When the Stop Mode, Parameter 65, configured for SMB and with the Input push button configured for the Stop Option

Figure 76 - Accu-Stop

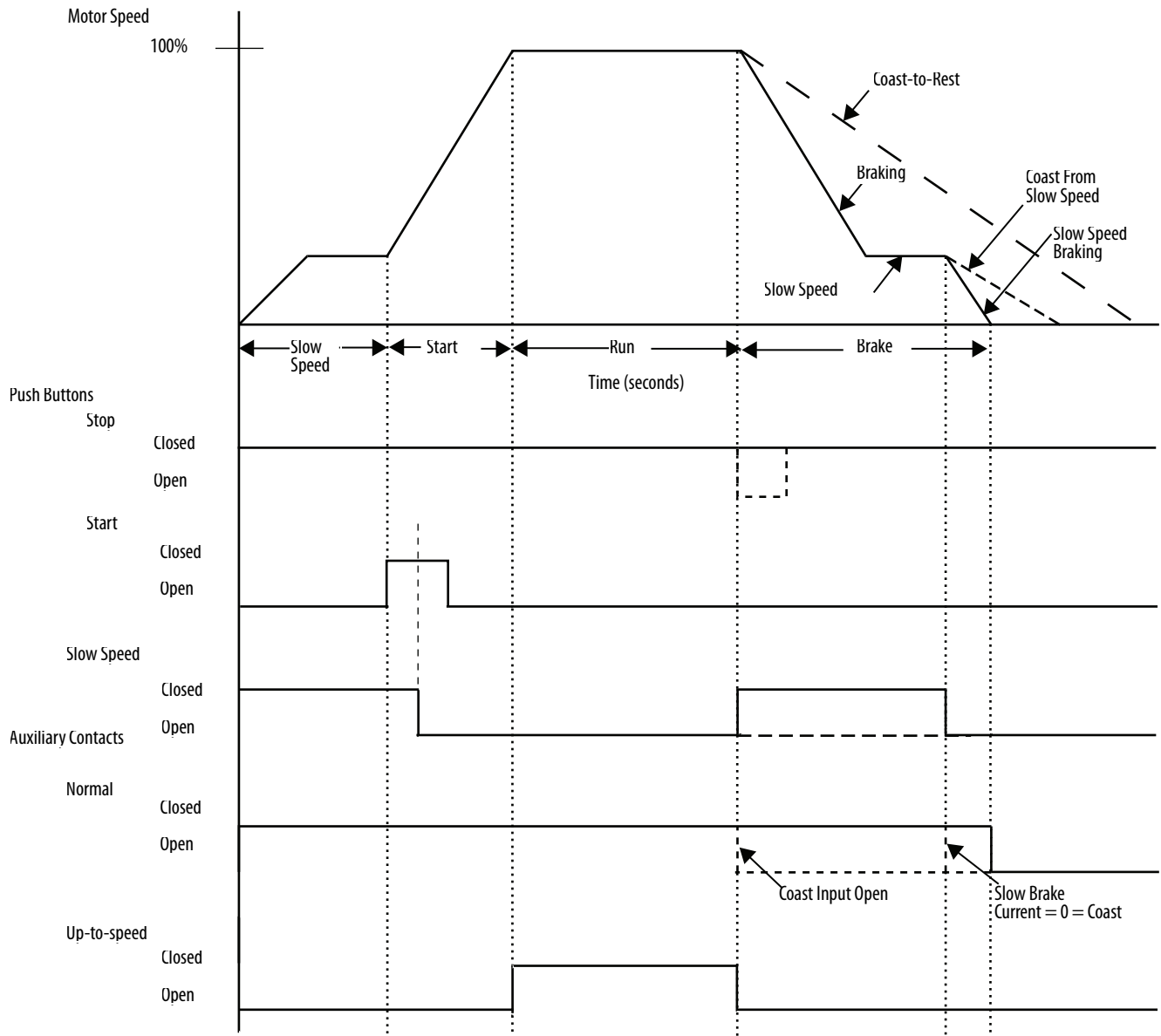

NOTE: Parameter Selections:

1. Parameter 65: Stop Mode = SMB
2. Parameter 69: Braking Current = User Defined Value
3. Parameter 72: Slow Speed = User Defined Value/Selection
4. Parameter 73: Slow Brake Cur = User Defined Value (0 selected enables Coast-to-Rest)

Figure 77 - Slow Speed with Braking

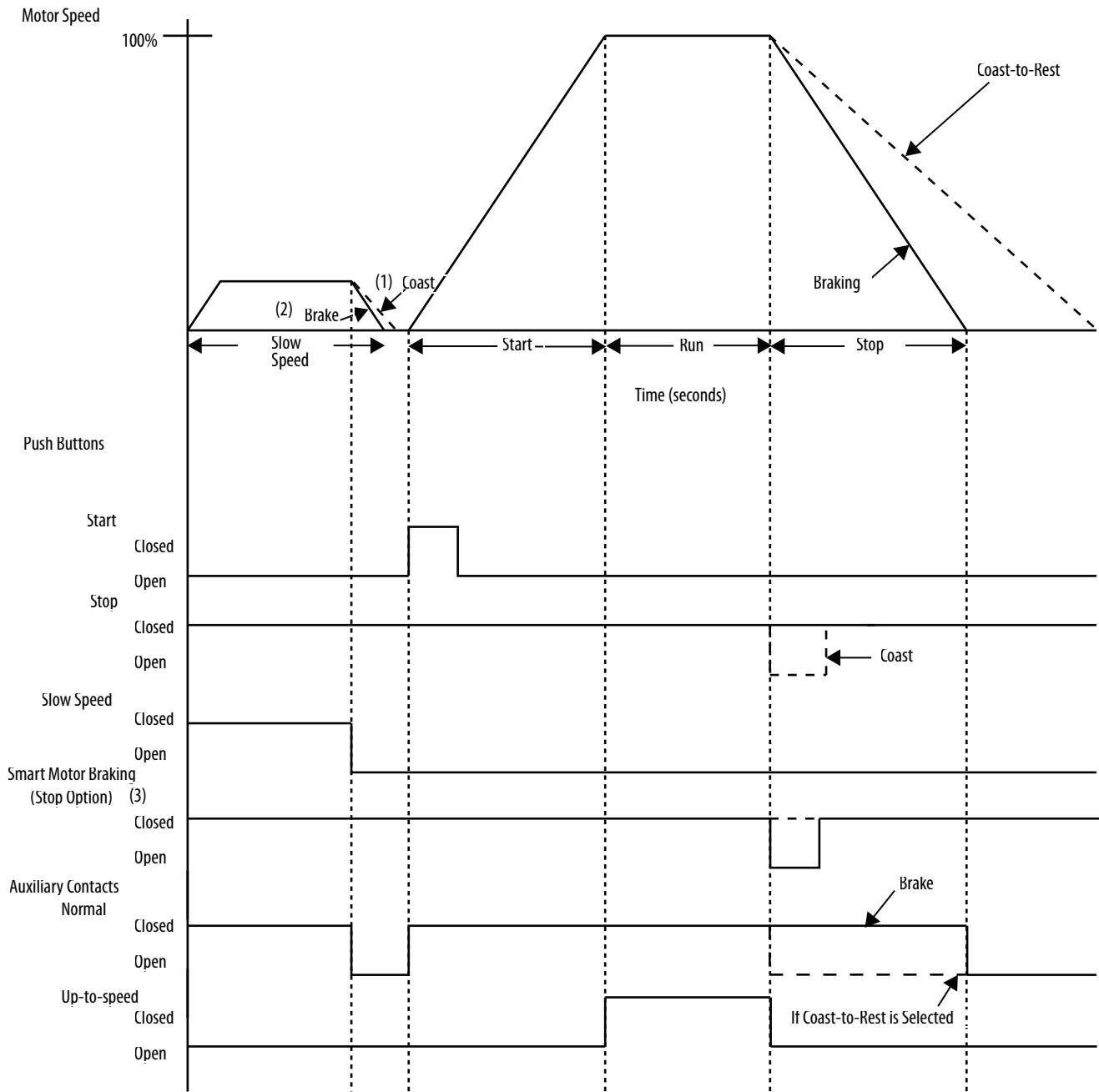

- (1) Coast if Slow Brake Cur Parameter = 0.
- (2) Brake if Slow Brake Cur Parameter >0 and <350.
- (3) When the Stop Mode, Parameter 65, configured for SMB and with the Input push button configured for the Stop Option.

Figure 78 - External Braking

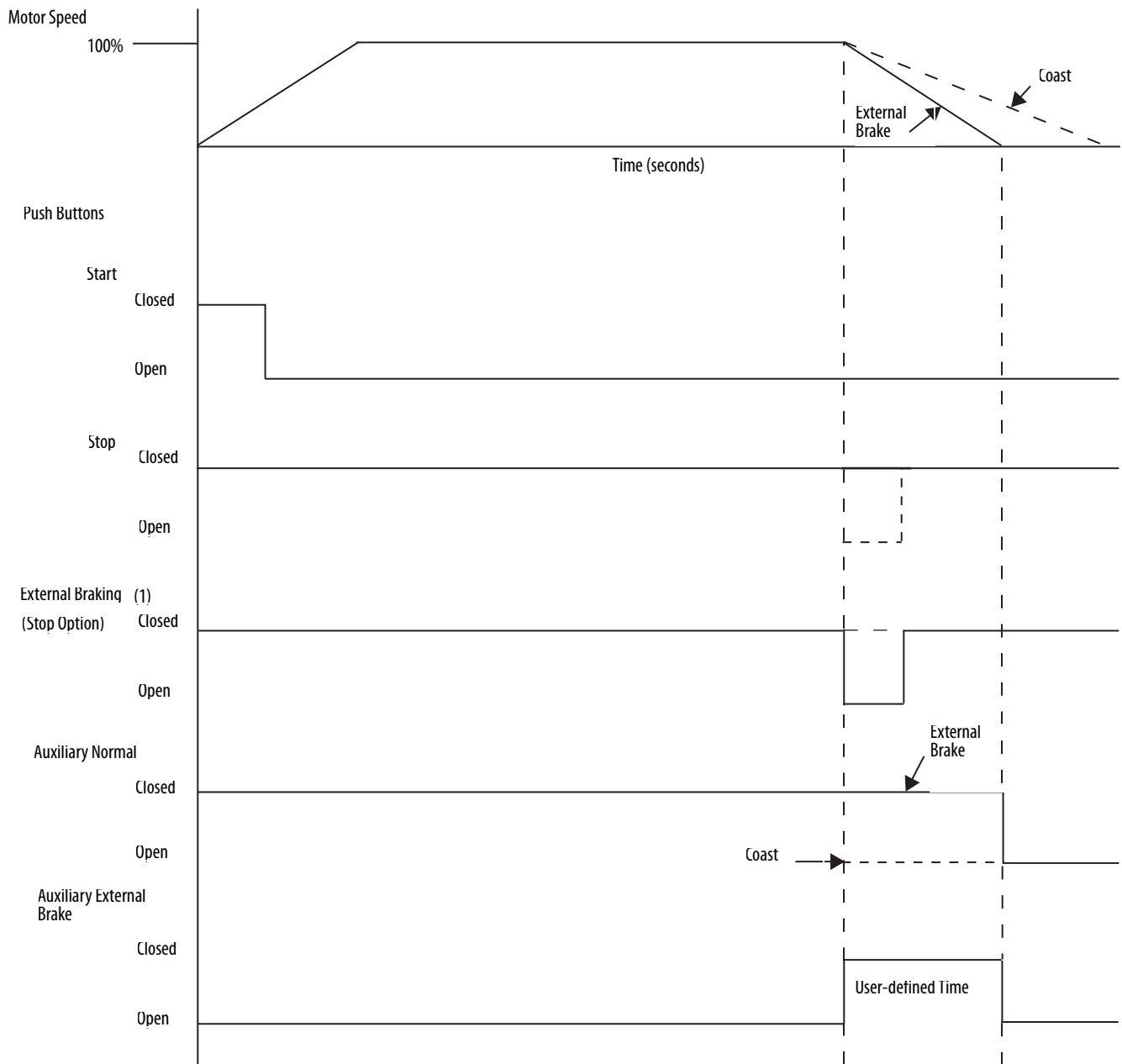

(1) When the Stop Mode, Parameter 65, is configured for Ext. Brake, (Eternal Brake) and the input push button is configured for STOP option.

Notes:

Special Application Considerations

Introduction

This chapter describes some extra application considerations for the SMC-50 controller.

Design Philosophy

SMC-50 controllers are designed to operate in today's industrial environments. Our controllers are manufactured to provide consistent and reliable operation.

Line Voltage Conditions

Voltage transients, disturbances, harmonics and noise exist in any industrial supply. A solid-state controller must be able to withstand these noises and should not be an unnecessary source of generating noise back into the line.

Ease of selection for the required line voltage is achieved with a design that provides operation over a wide voltage range, at 50/60 Hz, within a given controller rating.

Current and Thermal Ratings

Solid-state controller ratings must ensure reliability under the wide range of current levels and starting times needed in various applications.

Mechanical Shock and Vibration

Solid-state controllers must withstand the shock and vibration generated by the machinery that they control. SMC-50 controllers meet the same shock and vibration specifications as electromechanical starters.

Noise and Radio Frequency (RF) Immunity

This product meets Class A requirements for EMC emission levels.

Altitude

Altitudes up to 2000 meters (6560 ft) are permitted without de-rating. The allowable ambient temperature for the controller must be de-rated for altitudes

above 2000 meters (6560 ft). Utilizing the SMC Thermal Wizard helps you to determine the proper size SMC-50 controller.

Pollution

This product is intended for a Pollution Degree 2 environment.

Atmospheric Protection

ANSI/ISA-71.04-2013; Class G3 Environment.

Setup

Simple, easily understood settings provide identifiable, consistent results.

For ease of installation, the controllers include compact design and feed-through wiring. SMC-50 controllers are global products rated at 50/60 Hz. You can use multiple starting methods to program the controller, including an optional keypad with LCD display. Expandable inputs/outputs, analog, and communication cards are available to provide moire control flexibility.

Motor Overload Protection

When it is coordinated with the proper short-circuit protection, overload protection is intended to protect the motor, motor controller, and power wiring against overheating caused by excessive overcurrent. The SMC-50 controller meets applicable requirements as a motor overload protective device.

The SMC-50 controller incorporates, as standard, electronic motor overload protection. This overload protection is accomplished electronically with circuits and an I^2t algorithm.

The built-in overload protection is programmable, providing you with flexibility. The overload trip class can be selected for class OFF, or 5...30 protection. You can program the trip current to the motor full load current rating.

Thermal memory is included in the device functionality to model motor operating and cooling temperatures. Ambient insensitivity is inherent in the electronic design of the overload protection.

The SMC-50 controller has overload protection available for single-speed motors. When the SMC-50 controller is applied to a two-speed motor, you must disable the Overload function via Parameter #230—Motor Fault En and you must provide separate overload relays for each speed. [Figure 41 on page 63](#) shows an example of a motor protection wiring schematic.

Multiple Motors

The SMC-50 controller operates with more than one motor connected to it. Motors should be mechanically coupled. To size the controller, add the total nameplate amperes of all of the connected loads. You should turn off the stall and jam features. Separate overloads are still required to meet the National Electric Code (NEC) requirements.

Figure 79 - Multi-Motor Application

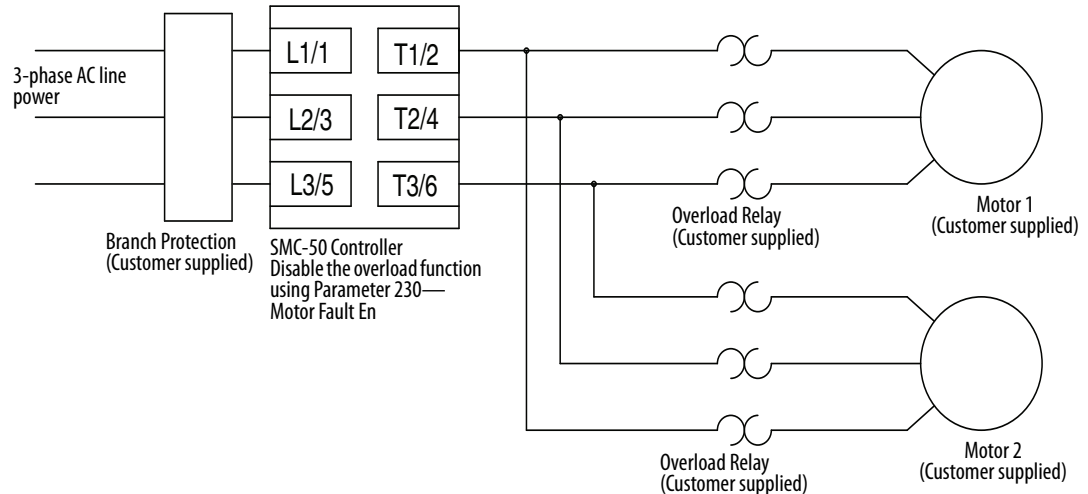

You cannot use the built-in overload protection in multi-motor applications. Disable the SMC-50 Overload function using Parameter #230—Motor Fault En

Special Motors

You can apply or retrofit the SMC-50 controller to special motors (wye-delta, part winding, synchronous, and wound rotor) as described in the following paragraphs.

Wye-Delta Motors

Wye-Delta is a traditional electromechanical method of reduced voltage starting. It requires a delta-wound motor with all of the leads brought out to facilitate a wye connection. At the start command, approximately 58% of full line voltage is applied, generating about 33% of the motor's full voltage starting torque capability. After an adjustable time interval, the motor is automatically connected in delta.

To apply an SMC-50 controller to a wye-delta motor, the power wiring from the SMC-50 controller is wired in an inside-the-delta configuration to the motor. This connects all six motor connections back to the SMC-50 controller. Because the controller applies a reduced-voltage start electronically, the transition

connection is no longer necessary. You can adjust the starting torque with parameter programming.

Figure 80 - Inside-the-Delta Wiring

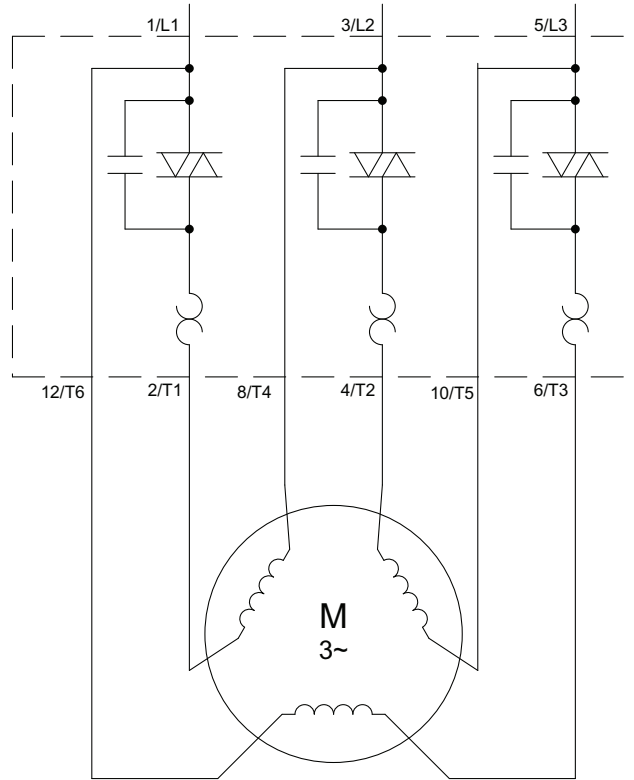

Part Winding

Part winding motors incorporate two separate, parallel windings in their design. In a traditional part winding starter, one set of windings is given full line voltage, and the motor draws about 400% of the motor’s full load current rating. About 45% of locked rotor torque is generated. After a preset interval, the second winding is brought online in parallel with the first and the motor develops normal torque.

You may wire the part winding motor to an SMC-50 controller by connecting both windings in parallel. You can adjust the starting torque to match the load with parameter programming.

Wound Rotor

Wound rotor motors require careful consideration when implementing SMC-50 controllers. A wound rotor motor depends on external resistors to develop high starting torque. It may be possible to develop enough starting torque using the SMC-50 controller and a single step of resistors. The resistors are placed in the rotor circuit until the motor reaches approximately 70% of synchronous speed. At this point, the resistors are removed from the secondary by a shorting contactor. Resistor sizing depends on the characteristics of the motor used.

It is not recommended to short the rotor slip rings during startup, because starting torque is greatly reduced, even with full voltage applied to the motor. The starting torque is even further reduced with the SMC-50 controller because the output voltage to the motor is reduced on startup.

Synchronous

Synchronous, brush-type motors differ from standard squirrel-cage motors in the construction of the rotor. The rotor of a synchronous motor is composed of two separate windings: a starting winding and a DC magnetic field winding.

The starting winding is used to accelerate the motor to about 95% of synchronous speed. Once it is at that level, the DC magnetic field winding is energized to pull the motor up to synchronous speed.

You can retrofit the SMC-50 controller to a synchronous controller by replacing the stator contactor with the SMC-50 controller and maintaining the DC field application package.

SMC-50 Motor Winding Heater

Internal

The SMC-50 motor winding heater function provides low levels of current to each of the motor windings to preheat a cold motor before starting. To avoid stressing a single motor winding, the SMC-50 controller cycles the current to the three motor phases. This feature provides a programmable heating level, heating time, and terminal block input.

You can activate the motor winding heater after it receives a valid start command. After a valid start, activate the heating function by programming the Heating Time parameter to a non-zero value or by configuring a terminal block input to "Motor Heater" and activating that input prior to the start command. The heater function continues for the specified time or until the input is deactivated, at which time the motor starts.

The heater function is disabled if the parameter Heater Level is set to zero or the parameter Heater Time is set to zero and the input is inactive (or not configured) at the time of the start command.

External

You can use an external Bulletin 1410 motor winding heater to realize the motor winding heater function.

Figure 81 - SMC-50 Controller with Bulletin 1410 Motor Winding Heater

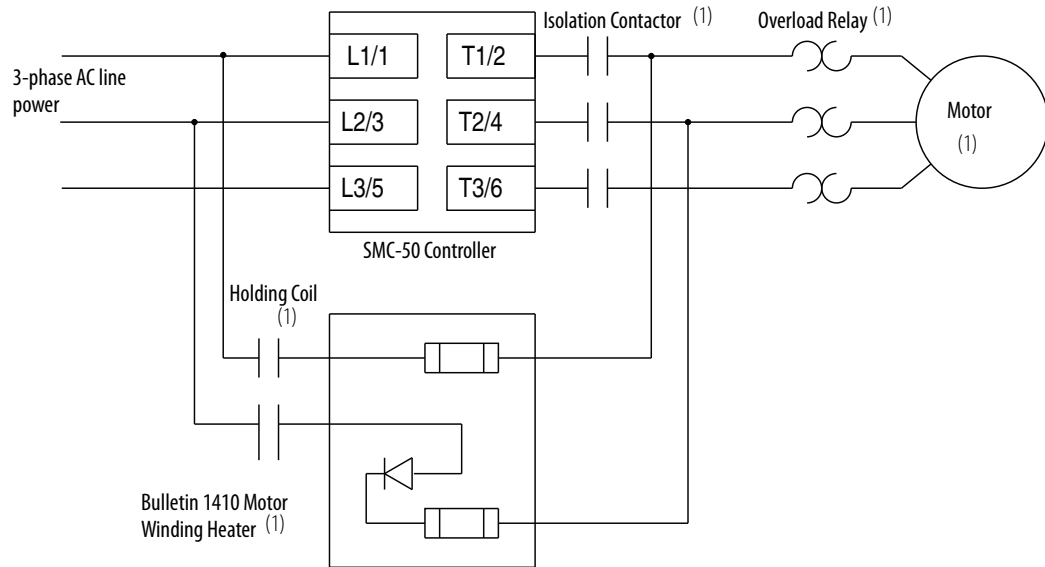

(1) Customer supplied.

Stall Protection and Jam Detection

Motors can experience locked rotor currents and develop high torque levels in the event of a stall or a jam. These conditions can result in winding insulation breakdown or mechanical damage to the connected load.

The SMC-50 controller provides both stall and jam detection for enhanced motor and system protection. Stall protection lets you program a maximum stall protection delay time from 0...30 seconds. The stall protection delay time is in addition to the programmed start time and begins only after the start time has elapsed.

Jam detection lets you determine the motor jam detection level as a percentage of the motor's full load current rating. To prevent nuisance tripping, You can program a jam detection delay time from 0...99 seconds. This lets you select the time delay required before the SMC-50 controller will trip on a motor jam condition. The motor current must remain above the jam detection level during the delay time. Jam detection is active only after the motor has reached full speed.

Communication

A serial interface port is furnished as standard on the SMC-50 controller. The connections lets you install a Bulletin 20-COMM communication module. Using the built-in communication capabilities, You can remotely access parameter settings, fault diagnostics, and metering. You can also perform remote start-stop control.

When used with the Bulletin 20-COMM communication modules, the SMC-50 controller offers true networking capabilities with several network protocols, including Allen-Bradley EtherNet, Remote I/O, DeviceNet network, RS 485, ControlNet™, ProfiBUS, and Interbus.

Power Monitoring

There are many ways in which You can use power data provided by the SMC-50 controller. These include helping to indicate when system maintenance is required, faulty equipment, pump application function, or monitoring power parameters for energy savings. Real, Reactive, and Apparent power calculations (along with demand and maximum demand) are made on each line power phase along with a total for all three phases.

The demand numbers are calculated as follows:

- Energy is calculated over a period of time defined by "Demand Period", Parameter 290.
- The previous "n" period values are averaged and the result is written to the Demand, Parameter 272, 281 and 288, which is used in calculating the Max Demand values. This averaging uses a rolling window algorithm in which the previous "n" periods are averaged.

Parameter Number	Name/Description	Min/Max	Default	Access	Units
269	Real Power A	± 1000.000	0.000	R	MW
270	Real Power B				
271	Real Power C				
10	Real Power				
11	Real Energy	± 1000.000	0.000	R	MWH
272	Real Demand	± 1000.000	0.000	R	MW
273	Max Real Demand				
274	Reactive Power A	± 1000.000	0.000	R	MVAR
275	Reactive Power B				
276	Reactive Power C				
277	Reactive Power				
278	Reactive Energy C	± 1000.000	0.000	R	MVRH
279	Reactive Energy P				
280	Reactive Energy	± 1000.000	0.000	R	MVRH
281	Reactive Demand	± 1000.000	0.000	R	MVAR
282	Max. Reactive Dmd				
283	Apparent Power A	± 1000.000	0.000	R	MVA
284	Apparent Power B				
285	Apparent Power C				
286	Apparent Power				
287	Apparent Energy				MVAH
288	Apparent Demand				MVA
289	Max. Apparent Demand				MVA
290	Demand Period	1...255	1	R/W	min
291	Number of Periods	1...15	1	R/W	—

Power Factor is calculated for each phase along with a total power factor value. The power factor calculation does not apply during Slow Speed and Braking operations.

Parameter Number	Name/Description	Min/Max	Default	Access	Units
292	Power Factor A	-1.00...1.00	0.00	R	NA
293	Power Factor B				
294	Power Factor C				
17	Power Factor				

Power Factor Correction Capacitors

You can install the SMC-50 controller on a system with power factor correction capacitors (PFCCs). The PFCCs must be located on the line side of the controller to prevent damage to the SCRs in the controller power section. When it is discharged, a capacitor essentially has zero impedance. For switching, sufficient impedance should be connected in series with the capacitor bank to limit the inrush current. One method for limiting the surge current is to add inductance in the PFCC conductors. You can do this by creating turns or coils in the power connections to the capacitors.

- 250V—150 mm (6 in.) diameter coil, 6 loops
- 480...690V—150 mm (6 in.) diameter coil, 8 loops

Figure 82 - PFCC Wiring

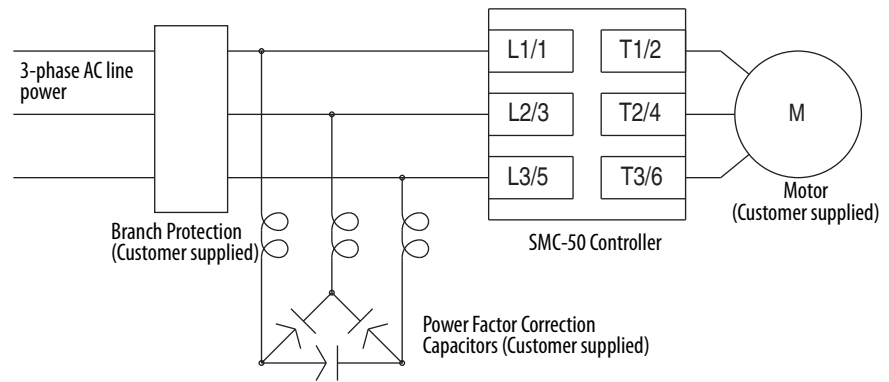

The SMC-50 controller can protect against excessive reactive power (MVAR). You can protect (Fault) or issue a warning (Alarm) if the motor reactive power (MVAR) consumption (+) or generation (-) is too high. You can use this protection with synchronous motors or motors that have active PFCCs.

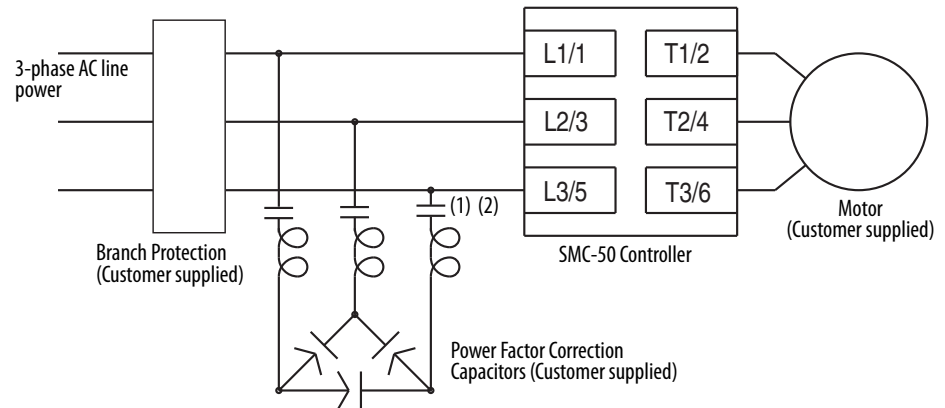

ATTENTION: SMC-50 controllers can be installed in a system with power factor correction capacitors (PFCCs). The PFCCs must only be on the line side of the controller. Placing the PFCCs on the load side of the SMC results in damage to the SCRs in the SMC-50 controller.

Figure 83 - PFCC with Contactor

- (1) Energize for 0.5 s before start command is given to SMC-50 controller.
 (2) Open contactor after the stopping method is complete.

Alternate method: use Aux Output configured for up-to-speed starting

- (1) Energize the contactor after the motor is up to speed.
 (2) Open contactor before initiating a stop command.

Altitude De-rating

Because of the decreased efficiency of fans and heat sinks, it is necessary to de-rate the SMC-50 controller above 6,500 feet (approximately 2,000 meters). For operation at 2000...7000 meters (6560...22965 feet), use the Thermal Wizard.

You can find the Thermal Wizard at <http://ab.rockwellautomation.com/> or under the Tools menu in ProposalWorks.

Note: Depending on the tool you use, your screen may differ from what is shown.

Note: You must keep the motor FLA Rating in the range of the current range of the SMC-50 controller.

Isolation Contactor

When it is installed with branch circuit protection and an overcurrent device, the SMC-50 controller is compatible with the National Electrical Code (NEC). When an isolation contactor is not used, hazardous voltages are present at the load terminals of the power module even when the controller is turned off. you must attach warning labels that indicate this hazard to the motor terminal box, the controller enclosure, and the control station.

Use the isolation contactor to provide automatic electrical isolation of the controller and motor circuit when the controller is shut down. Shut down can occur in either of two ways: either manually, by pressing the stop button; or automatically, by the presence of abnormal conditions (such as a motor overload relay trip).

The isolation contactor carries only the load current under normal conditions. During start, the isolation contactor is energized before the SCRs are gated “on.” While stopping, the SCRs are gated “off” before the isolation contactor is de-energized. The isolation contactor does not make or break the load current.

Figure 84 - Typical Connection Diagram with Isolation Contactor

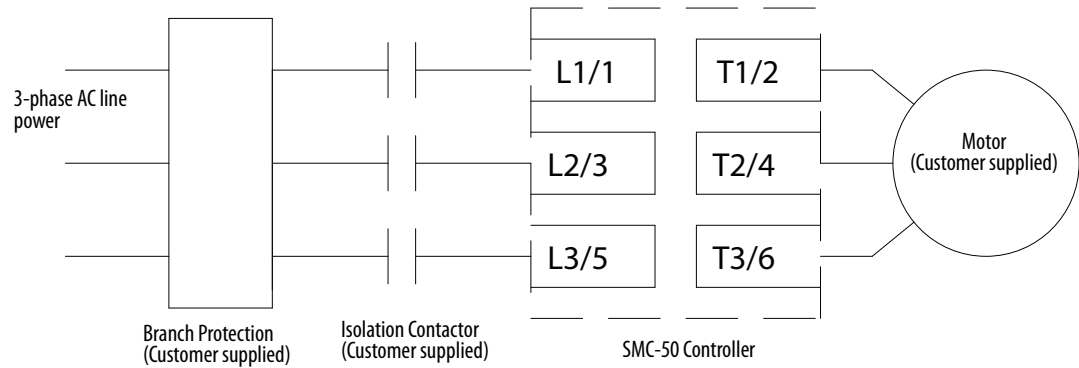

Application Uses for SMC-50 Controller Power Structures

SMC-50 Solid-state Controller

Figure 85 - SMC-50 Controller Solid-state Power Structure

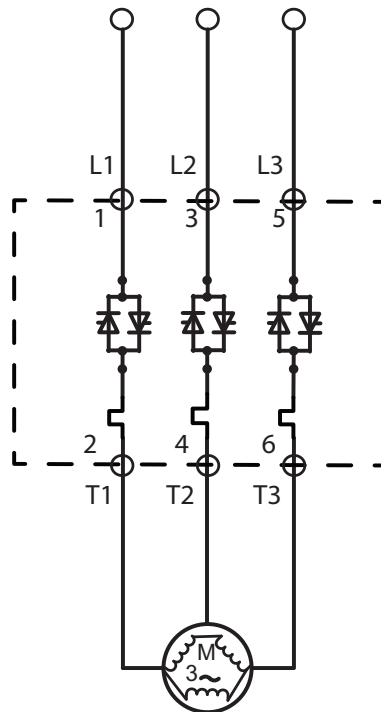

Fully solid-state devices are advantageous in harsh applications where there is a lot of vibration, dust, and dirt.

Conformal-coated circuit boards on the SMC-50 controller help to protect component damage from conductive or corrosive dust in those types of environments. Vibration is not a concern unlike with an electromechanical bypass contactor, where vibration could potentially cause contact bounce.

Other applications for fully solid-state device include those in which there is a high duty cycle. Applications that use a solid-state contactor are potentially appropriate for a solid-state soft starter. The solid-state starter provides starting and stopping methods and feedback that a solid-state contactor is not able to provide.

Solid-state soft starters like the SMC-50 controller have predefined ratings for normal duty and heavy duty applications.

Utilization Categories Defined:

- Normal Duty Rating
 - AC-53a:3.5-10:99-2: 350% current limit, 10 second start, 99% ON load factor and 2 starts per hour; 40 °C surrounding ambient temperature rating
 - Ideal for Pumps and Compressors
- Heavy Duty Rating
 - AC-53a:3.5-30:99-1: 350%, 30 second start, 99% ON load factor and 1 start per hour; 50 °C surrounding ambient temperature rating
 - Ideal for harsh environments or more demanding applications (for example, chippers, rock crushers)

SMC-50 Controller with Integrated Bypass

Figure 86 - SMC-50 Controller Integrated Bypass Power Structure

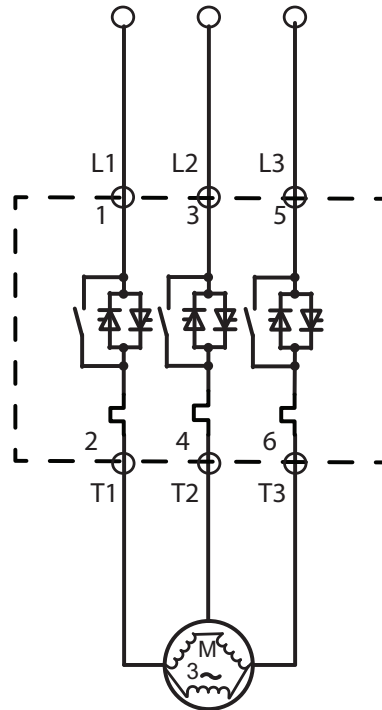

The internal bypass contactor is used after the soft starter has brought the motor up to speed. The algorithm of the soft starter determines when the motor is up to speed and, at that time, transitions from SCR control to the bypass contactor. Rockwell Automation offers a hybrid soft starter that has the power structure of a solid-state starter and an internal bypass contactor.

Attributes of an internal bypass contactor allow the soft starter to operate at a lower temperature with the motor at speed compared to a fully solid-state starter. A hybrid soft starter is typically smaller than fully rated SCRs with no bypass. The reason for this is smaller components are used to start and carry the load current. The SCRs are rated for intermittent duty (AC-53b). The internal bypass contactors are typically not fully rated (AC-3), because they are typically designed to not make or break load current.

When you use an internal bypass soft starter, you only need power and control wiring. You do not need to purchase any additional devices. Internal bypass on a soft starter is suitable for conveyors, fans, pumps and other applications where the current and speed does not change while at speed.

The utilization code for the hybrid version:

- AC-53b: 3.0-50:1750
 - 300% current limit, 50 second start, off-time must not be less than 1750 seconds between starts.

SMC-50 Controller with External Bypass

Figure 87 - Soft Starter with External Bypass Contactor

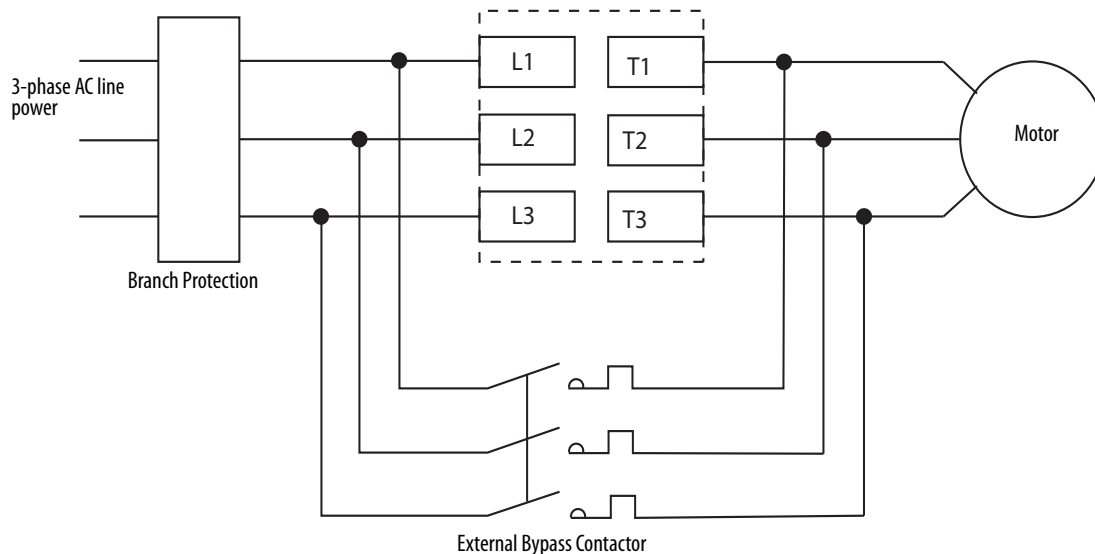

Soft starters can use internal or external bypass contactors. Depending on the application, an external bypass may be a better choice than an internal bypass. In some cases, because of application considerations, a soft starter may have an

internal bypass, but be configured to use auxiliary contacts/outputs to control an external bypass.

Applications that are good for external bypass contactors are those where you need a soft start, but while in run mode, current may spike due to product jams or plugging. For example, in a rock crushing application, there is a high chance of jamming material in a hopper, which causes current spikes. A soft starter with an internal bypass contactor monitors current and may typically drop out of bypass to protect the contactor and return to SCR control. Once the current returns to normal, the bypass contactor is pulled back in. This cycling on and off could shorten the life of an internal electromechanical contactor.

Not having all protective features of the soft starter during the run mode may be a benefit to keep an application like rock crushing working. In that application, using an external bypass contactor that is fully rated to handle the current surges keeps the contactor pulled in until a stop command is given or an overload is tripped. External overloads may be needed to protect the motor because some soft starters may not be able to read motor data while in external bypass mode.

An external bypass contactor may also be used on a AC-53a-rated fully solid-state soft starter. Depending on both the soft starter and the mounting and wiring of the bypass contactor, there may or may not be a need for external overloads. The mounting features from the soft start to the bypass contactor dictate whether the soft starter can read data (current and voltage readings) while in bypass mode.

In UL/CSA regulated regions, size the bypass contactor according to the motor Hp and FLA. In IEC regulated regions, size the bypass conductor per the AC-1 rated bypass contactor rating.

The Hp ratings of the AC-3 rated bypass contactor must match the Hp ratings of the SMC-50 soft starter. The short-circuit ratings of the bypass contactor must be similar to the SMC-50 soft starter. This is particularly important for the AC-1 rated bypass contactor selection.

Protection and Diagnostic Functions

Overview

The SMC-50 controller provides both diagnostic and protection functions. Control these functions via user-configured parameters that provide motor and starter alarm and faults. You can individually enable or disable each configurable alarm and fault. Many alarms and faults also have a user-defined time delay to help limit nuisance tripping. A fault condition shuts down the controller. You can use an alarm to alert an operator to a pending fault. You can individually configure motor and starter faults for automatic reset/restart after configuring the number of restart attempts and restart time delay. Restart attempts and restart delay are universal to all faults. See [page 153](#) for additional details.

A multi-colored (red, green, amber) STATUS LED is located on the front of the SMC-50 controller directly below the bezel/pocket for the 20-HIM-A6.

Figure 88 - Controller Status LED

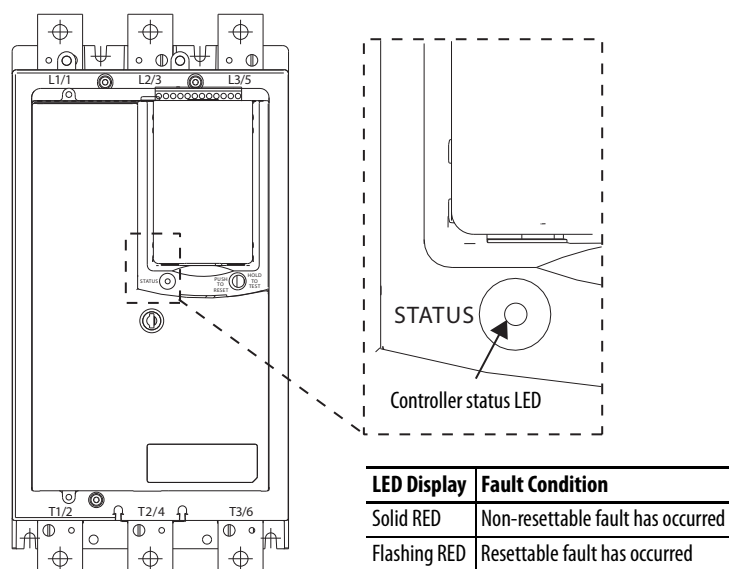

Additional diagnostic LEDs are located on the optional Bulletin 150-SM6 Parameter Configuration Module (PCM). This module provides simple and limited parameter configurations. For additional diagnostic LED information, see [Chapter 10](#).

20-HIM-A6, 20-HIM-C6S, and Configuration Software

The 20-HIM-A6, 20-HIM-C6S, and PC configuration/monitoring software (for example, Connected Components Workbench software) provide detailed Fault and Alarm information. When the SMC-50 controller has a fault, the HIM display indicates FAULTED along with the Fault Code, a simple fault description, and the elapsed time since the fault occurred. Other HIM screens provide more detailed data and the ability to reset the Fault/Alarm from the keypad. For more details about the diagnostic use of these tools, see [Chapter 10, Diagnostics](#).

To simplify identifying the source of a DPI port related Fault or Alarm, the SMC-50 controller displays the DPI port number when posting the Fault or Alarm number.

EXAMPLE If a 150-SM4 Digital I/O Option Module is located in the SMC-50 controller DPI Port 7 and is the source of a Fault, port number 7 is displayed with the Fault Code (for example, Port 7, Fault 26 is displayed as 7026).

Table 24 - SMC-50 Controller DPI-Assigned Port Numbers and Source

DPI Port Number	Source	DPI Port Number	Source
0	SMC-50 Controller	6	Reserved
1	Front-Mounted HIM	7	Control Module Port 7
2	Remote DPI (top of SMC-50 controller)	8	Control Module Port 8
3 ⁽¹⁾	Remote DPI	9 ⁽²⁾	Control Module Port 9
4 ⁽²⁾	20-COMM-X Module	10-15	Reserved
5	Reserved		

(1) To access Port 3, the use of a 1203-S03 splitter inserted into Port 2 is required.

(2) When using a 20-COMM-X network communication module, it must physically be located in Control Module Port 9. However, its DPI Port Number assignment is 4 because of the cable connection to the DPI Port 4 located below the front-mounted HIM.

Enabling Starter and Motor Faults and Alarms

You can individually configure, enable, and disable motor and starter Faults and Alarms. The parameters Motor Fault En, Starter Fault En, Motor Alarm En, and Starter Alarm En are numbered bit fields for configuration to enable (bit=1) or disable (bit=0) specific motor and/or starter Faults and Alarms. You can do this by using configuration tools (for example, HIM or PC software) or network communications.

Because there are more than 32 Faults and Alarms, the configuration bits are located in the lower and upper 16-bit fields (numbered 0-31) of the associated SMC-50 controller parameters. The bits are divided into starter Faults and motor Faults.

These parameters do not enable or disable Faults that can generated by expansion modules (for example, 150-SM2, -SM4, etc.). When an expansion

module is plugged into a control module port (7, 8, or 9), a set of configuration parameters appears to enable configuration of that specific module.

[Table 25](#) and [Table 26](#) provide an overview of the motor and starter Fault and Alarm Enable parameters. All bits are read (R) and write (W) enabled.

Table 25 - Enable/Disable Starter Fault/Alarm Matrix

Parameter Number	Function/Description ⁽¹⁾	Fault/Alarm Name ⁽¹⁾	Bit Assignment	Bit Access	Units [Default]
Starter Fault					
136	Starter Fault En	Volt Unbal	0	R/W	Bit = 0 Disabled Bit = 1 Enabled [Enabled]
		Overvoltage	1		
		Undervoltage	2		
		Phase Rev	3		
		[Line Loss]	4		
		[Open Gate]	5		
		Config Change	6		
		Freq	7		
THD V	8				
Starter Alarm					
137	Starter Alarm En	Volt Unbal	0	R/W	Bit = 0 Disabled Bit = 1 Enabled [All Disabled as Default]
		Overvoltage	1		
		Undervoltage	2		
		Phase Rev	3		
		Line Loss	4		
		Open Gate	5		
		Config Change	6		
		Freq	7		
THD V	8				

(1) As displayed on the HIM or Connected Components Workbench configuration tools

Table 26 - Enable/Disable Motor Fault/Alarm Matrix

Parameter Number	Function/Description ⁽¹⁾	Fault/Alarm Name ⁽¹⁾	Bit Assignment	Bit Access	Units [Default]
Motor Fault					
230	Motor Fault En	[Overload]	0	R/W	Bit = 0 Disabled Bit = 1 Enabled [Enabled]
		Underload	1		
		MWatts Over	2		
		MWatts Under	3		
		+MVAR Over	4		
		+MVAR Under	5		
		-MVAR Over	6		
		-MVAR Under	7		
		MVA Under	8		
		MVA Over	9		
		Curr Imbal	10		
		Jam	11		
		Stall	12		
		Starts/Hr	13		
		PM Hours	14		
		PM Starts	15		
		[Power Qual]	16		
		[Open Load]	27		
		THD1	18		
		Lead PF Un	19		
		Lead PF Ov	20		
		Lag PF Un	21		
		Lag PF Ov	22		
Locked Rotor	23				
Motor Alarm					
231	Motor Alarm En	Overload	0	R/W	Bit = 0 Disabled Bit = 1 Enabled [All Disabled as Default]
		Underload	1		
		MWatts Over	2		
		MWatts Under	3		
		+MVAR Over	4		
		+MVAR Under	5		
		-MVAR Over	6		
		-MVAR Under	7		
		MVA Under	8		
		MVA Over	9		
		Curr Imbal	10		
		Jam	11		
		Stall	12		
		Starts/Hr	13		
		PM Hours	14		
		PM Starts	15		
		Power Qual	16		
		Open Load	27		
		THD1	18		
		Lead PF Un	19		
		Lead PF Ov	20		
		Lag PF Un	21		
		Lag PF Ov	22		
Locked Rotor	23				

(1) As displayed on the HIM or Connected Components Workbench configuration tools

Enabling Option Module Functional Faults and Alarm

Not all option modules have faults and alarms associated with their specific function(s). For example, the 150-SM4 Option I/O and 150-SM6 Parameter Configuration Modules **do not** have functional faults or alarms. When an option module does have functional faults and alarms, it also can individually configure, enable, and disable them like faults and alarms for the controller and motor.

150-SM2 Option Module

The 150-SM2 Option Module has individually enabled faults and alarms associated with the Ground Fault and Motor PTC functions, shown in [Table 27](#).

Table 27 - 150-SM2 Faults and Alarms

Parameter Number	Function/Description ⁽²⁾	Fault/Alarm Name ⁽²⁾	Bit Assignment	Bit Access	Units [Default]
X02 ⁽¹⁾	Fault En	PTC	0	R/W	NOTE: Bit=0 Disabled Bit=1 Enabled [All Disabled]
		Gnd Flt	1		
X03 ⁽¹⁾	Alarm En	PTC	0	R/W	
		Gnd Flt	1		

(1) X = the control module port number (7 or 8) in which the 150-SM2 resides.

(2) As displayed on the HIM or Connected Components Workbench configuration tools

150-SM3 Option Module

The 150-SM3 Option Module has individually enabled faults and alarms associated with the analog inputs and outputs, shown in [Table 28](#).

Table 28 - 150-SM3 Faults and Alarms

Parameter Number	Function/Description ⁽²⁾	Fault/Alarm Name ⁽²⁾	Bit Assignment	Bit Access	Units [Default]
X37 ⁽¹⁾	Fault En	IN1 Over	0	R/W	NOTE: Bit=0 Disabled Bit=1 Enabled [All Disabled]
		IN1 Under	1		
		IN2 Over	2		
		IN2 Under	3		
		OUT1 Shorted	4		
		OUT1 Open	5		
		OUT2 Shorted	6		
OUT2 Open	7				
X38 ⁽¹⁾	Alarm En	IN1 Over	0	R/W	
		IN1 Under	1		
		IN2 Over	2		
		IN2 Under	3		
		OUT1 Shorted	4		
		OUT1 Open	5		
		OUT2 Shorted	6		
OUT2 Open	7				

(1) X = the control module port number (7 or 8) in which the 150-SM3 resides.

(2) As displayed on the HIM or Connected Components Workbench configuration tools

Protection and Diagnostics

The following describes the SMC-50 controller protection and diagnostic functions.

Overload—Fault and Alarm

Overload Fault (Code 21)

The SMC-50 controller meets applicable requirements as a motor overload protective device. Thermal memory provides added protection and maintains motor thermal data when control power is removed.

The SMC-50 controller provides overload protection through true RMS current measurement of the individual phase currents of the connected motor. A thermal model that simulates the actual heating of the motor is calculated based on the following:

- measured maximum motor current value,
- Motor FLC Setting, Parameter 78,
- Overload (Trip) Class⁽¹⁾ Setting, Parameter 75, and
- Motor Service Factor, Parameter 77, (obtained from the motor nameplate)

The Motor Thermal Usage (MTU), Parameter 18, displays the percentage of the motor overload currently utilized. The SMC-50 controller overload fault will trip the motor when (1) the motor overload fault is enabled **and** (2) the MTU reaches 100%.

The overload function calculates and provides motor overload data through:

- MTU, Parameter 18,
- Time to OL Trip, Parameter 19, and
- Time to OL Reset, Parameter 20.

TIP Trip rating is 118% of the programmed motor FLC.

The SMC-50 controller continues to calculate the reduction in MTU (decay rate) when the motor is powered down (cooling). Enable this by using the SMC-50 controller's real time clock (RTC) function. When control power is lost, the SMC-50 controller saves the power down thermal level and time. When power is reapplied, the SMC-50 controller reads the current time, power down time, and power down thermal level. From this data, the SMC-50 controller calculates the new thermal information for the overload.

(1) Trip Class is defined as the maximum time in seconds for an overload trip to occur when the motor's operating current is six times its rated current. The SMC-50 controller overload function offers an adjustable Trip Class range of 5...30, which can be programmed in increments of one via Overload Class, Parameter 75, and Overload Class 2, Parameter 76 (configuration for a second overload Class).

Overload Alarm

In addition to the Overload Fault, an Overload Alarm is also available. The desired value or level of the alarm is set up with Overload Alarm Level, (Overload A Lvl), Parameter 83, which can be set from 0% to 100%. When the MTU value reaches the set percentage of the thermal trip level, then the alarm becomes active. When the MTU value falls below the set percentage of the thermal trip level, the alarm becomes inactive.

Motor Thermal Usage (Mtr Therm Usage), Parameter 18, provides the current motor thermal usage value. This parameter reads from 0% to 200%, where 100% corresponds to a fault condition.

Figure 89 - Overload Trip Curves

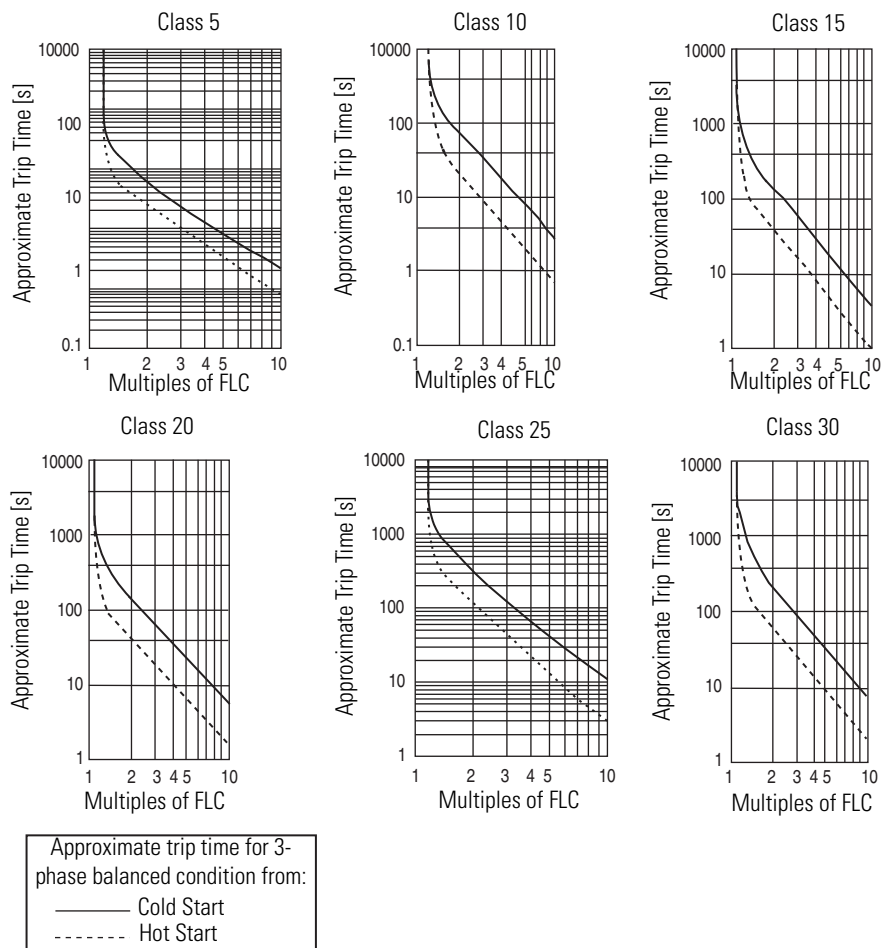
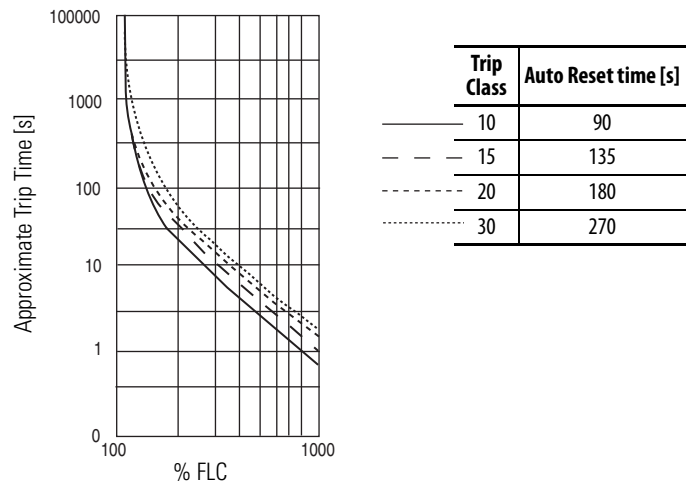

Figure 90 - Restart Trip Curves after Auto Reset



Overload Shunt Time, Parameter 81, allows disabling (shunt) the overload at the beginning of the start cycle. The length of time that the overload is disabled (shunted) is defined by this parameter. The motor overload does not accumulate data (MTU) during this period.

You can configure the SMC-50 controller to automatically reset the overload fault when it has cooled to the set Overload Reset Level, Parameter 80. You must enable the Motor Restart Enabled (Motor Restart En), Parameter 264, (Overload = Set) to allow the Overload Reset Level parameter to function.

The Time to Overload Trip (Time to OL Trip), Parameter 19, provides indication of how much time is left before an overload trip occurs given the current operating conditions. If the overload fault is disabled, this parameter reads its maximum value.

The Time to OL Reset, Parameter 20, provides indication of how much time is left before an overload fault clears based on the cooling (decay) algorithm. If the overload parameter is disabled or has not tripped, then this parameter is zero.

Table 29 - Overload Parameter List

Parameter Number	Parameter Name ⁽¹⁾	Minimum/Maximum Value	Default Value	Access	Units
75	Overload Class	5...30	10	R/W	—
76	Overload Class 2 ⁽²⁾	5...30	10		—
77	Service Factor	0.01...1.99	1.15		—
78	Motor FLC	1.0...2200.0	1.0		Amps
80	OL Reset Level	1...99	75		%MTU
18	Motor Therm Usage	0...200	0...200	R	%MTU
81	OL Shunt Time	0...999	0	R/W	SECS
82	OL Inhibit Time	0...999	0		SECS
83	Overload A Lvl	0...100	0		%MTU
19	Time to OL Trip	0...10000	0...10000	R	SECS
20	Time to OL Reset	0...10000	0...10000		SECS
84	Locked Rtr Level	400...1000	600	R/W	%FLC
85	Locked Rtr Time	1...1000	1	R/W	SECS

(1) As displayed on the HIM or Connected Components Workbench software configuration tools.

(2) Configuration for a second overload Class.

Underload—Fault and Alarm

The SMC-50 controller lets you trip on underload when the motor current falls below a user-defined level for a user-defined time.

Underload Fault (Code 22)

Motor current less than a specific level may indicate a mechanical malfunction in the installation (for example, a torn conveyor belt, damaged fan blade, broken shaft, or worn tool). Such conditions may not harm the motor, but can lead to loss of production. Rapid Underload Fault detection helps to minimize damage and loss of production.

Underload Fault current protection, Fault Code 22, is enabled or disabled via the motor Underload Enable/Disable bit in the Motor Fault Enable, Parameter 230. Configure the value or level of the Fault current by using Underload Fault Level (Underload F Lvl), Parameter 86. A configurable Fault Delay Time using Underload Fault Delay (Underload F Dly), Parameter 87, is also available to help eliminate nuisance faults.

Underload Alarm

A motor Underload Alarm is also available. Configure this exactly as the Underload Fault using Underload Alarm Level (Underload A Lvl), Parameter 88, and Underload Alarm Delay (Underload A Dly), Parameter 89. You can enable or disable the Alarm by using the Underload bit in the Motor Alarm Enabled, Parameter 231.

The SMC-50 controller checks for a motor Underload condition approximately every 0.025 seconds.

TIP Underload protection is active when the motor is at speed.

Table 30 - Underload Parameter List

Parameter Number	Parameter Name ⁽¹⁾	Minimum/Maximum Value	Default Value	Access	Units
86	Underload F Lvl	0...99	0	R/W	%FLC
87	Underload F Dly	0.1...99	0.1		SECS
88	Underload A Lvl	0...99	0		%FLC
89	Underload A Dly	0.1...99	0.1		SECS

(1) As displayed on the HIM or Connected Components Workbench configuration tools.

Line Power Undervoltage Protection

Undervoltage Fault (Code 20)

The SMC-50 controller can protect against low line power voltage. The Undervoltage Fault, Code 20, provides protection from a line power undervoltage condition. An undervoltage fault condition exists if the average of the three-phase Line Voltage (Line Voltage), Parameter 46, falls below the user-defined voltage level (Undervolt F Lvl), Parameter 98, for a user-defined time Undervolt Fault Delay. See [Table 31](#)

Enable or disable Undervoltage Fault protection via the Undervoltage Enable/Disable bit in the Starter Fault Enable, Parameter 136.

Undervoltage Alarm

In addition to the Fault, an Undervoltage Alarm is also available. Set this exactly like the Fault using the "Undervolt A Lvl", Parameter 100, and the "Undervolt A Dly", Parameter 101. The Undervoltage Alarm is enabled or disabled via the Undervoltage Enable/Disable bit in the Starter Alarm Enable, Parameter 137.

Table 31 - Undervoltage Protection Parameter List

Parameter Number	Parameter Name ⁽¹⁾	Minimum/Maximum Value	Default Value	Access	Units
46	Line Voltage	0...700	400	R/W	Volts
98	Undervolt F Lvl	0...100	90		%V
99	Undervolt F Dly	0.1...99.0	3.0		SECS
100	Undervolt A Lvl	0...100	90		%V
101	Undervolt A Dly	0.1...99.0	3.0		SECS

(1) As displayed on the HIM or Connected Components Workbench configuration tools.

Line Power Overvoltage Protection—Fault and Alarm

Overvoltage Fault (Code 19)

The SMC-50 controller can protect against high line power voltage. The Overvoltage Fault, Code 19, provides protection from a line power Overvoltage condition. An overvoltage condition exists if the average of the three-phase line voltage exceeds a user-defined percent above that level (Overvolt F Lvl) for a user-defined time, "Overvolt F Dly". See [Table 32 on page 131](#).

Overvoltage protection is enabled or disabled via the Overvoltage Enable/Disable bit in the Starter Fault Enable, Parameter 136.

Overvoltage Alarm

In addition to the Fault, an Overvoltage Alarm is also available. This is set up exactly as like the Overvoltage Fault using the Overvoltage Alarm Level and Overvoltage Alarm Delay parameters.

The Overvoltage Alarm is enabled or disabled via the Overvoltage Enable/Disable bit in the Starter Alarm Enable, Parameter 137.

Table 32 - Overvoltage Protection Parameter List

Parameter Number	Parameter Name ⁽¹⁾	Minimum/Maximum Value	Default Value	Access	Units
46	Line Voltage	0...700	400	R/W	Volts
102	Overvolt F Lvl	100...199	440		%
103	Overvolt F Dly	0.1...99.0	3.0		SECS
104	Overvolt A Lvl	100...199	110		%
105	Overvolt A Dly	0.1...99.0	3.0		SECS

(1) As displayed on the HIM or Connected Components Workbench configuration tools.

Current Imbalance Protection—Fault and Alarm

A current imbalance condition can be caused by an unbalance in the voltage supply, unequal motor winding impedance, or long and varying wire lengths. When a current imbalance condition exists, the motor can experience an additional temperature rise, which results in degradation of the motor insulation and reduction in life expectancy. Rapid current imbalance fault detection helps to extend the motor's life expectancy and minimize potential damage and loss of production.

The current imbalance calculation is equal to the largest deviation of the three current signals (RMS phase current) from the average phase current, divided by the average phase current. Note that the power pole current is used for the current imbalance calculation.

Current Imbalance Fault (Code 42)

A Current Imbalance Fault condition, Fault Code 42, occurs when the calculated imbalance level rises above a user-defined level, Current Imbalance Fault Level, for a user-defined time, Current Imbalance Fault Delay. See [Table 33 on page 132](#).

Current imbalance protection is enabled or disabled using the Current Imbalance bit in the Motor Fault Enable, Parameter 230.

Current Imbalance Alarm

In addition to the Current Imbalance Fault, a Current Imbalance Alarm is also available. Set this exactly like the Current Imbalance Fault using the Current Imbalance Alarm Level and Current Imbalance Alarm Delay parameters. You can enable or disable the Current Imbalance Alarm by using the Current Imbalance bit in the Motor Alarm Enable, Parameter 231.

Table 33 - Current Imbalance Parameter List

Parameter Number	Parameter Name ⁽¹⁾	Minimum/Maximum Value	Default Value	Access	Units
110	Cur Imbal F Lvl	1...25	15	R/W	%
111	Cur Imbal F Dly	0.1...99.0	3.0		SECS
112	Cur Imbal A Lvl	1...25	10		%
113	Cur Imbal A Dly	0.1...99.0	3.0		SECS

(1) As displayed on the HIM or Connected Components Workbench configuration tools.

Voltage Unbalance Protection—Fault and Alarm

An unbalance in the voltage supply results in a current imbalance. This causes the motor to experience an additional temperature rise, resulting in degradation of the motor insulation and reducing its life expectancy. Voltage unbalance detection helps extend the motor life expectancy and minimize potential damage and loss of production.

The voltage unbalance (V_u) calculation is equal to the largest deviation (V_d) of the three-phase voltage signals (RMS phase voltage) from the average of the RMS phase voltage (V_{ave}), divided by the average voltage.

$$V_u\% = 100 \left(\frac{V_d}{V_{ave}} \right)$$

Note that the phase-to-phase voltage is used in the calculation for voltage unbalance.

Voltage Unbalance Fault (Code 18)

A Voltage Unbalance Fault condition, Fault Code 18, occurs when the calculated unbalance level rises above a user-defined level, Voltage Unbalance

Fault Level, for a user-defined time, Voltage Unbalance Fault Delay. See Table 34 on page 133.

Voltage unbalance protection is enabled or disabled using the Voltage Unbalance bit in the Starter Fault Enable, Parameter 136.

Voltage Unbalance Alarm

In addition to the Voltage Unbalance Fault, a Voltage Unbalance Alarm is also available. Set this up exactly like Voltage Unbalance Fault by using the Voltage Unbalance Alarm Level and Voltage Unbalance Alarm Delay parameters. Enable or disable this Voltage Unbalance Alarm by using the Voltage Unbalance bit in the Starter Alarm Enable, Parameter 137.

Table 34 - Voltage Unbalance Protection Parameter List

Parameter Number	Parameter Name ⁽¹⁾	Minimum/Maximum Value	Default Value	Access	Units
106	Volt Unbal F Lvl	1...25	15	R/W	%
107	Volt Unbal F Dly	0.1...99.0	3.0		SECS
108	Volt Unbal A Lvl	1...25	10		%
109	Volt Unbal A Dly	0.1...99.0	3.0		SECS

(1) As displayed on the HIM or Connected Components Workbench configuration tools.

Phase Reversal Protection

Phase Reversal Fault (Code 25)

The SMC-50 controller provides Fault Protection, Fault Code 25, against reverse connection (CBA) of line power phases.

You can enable or disable Phase Reversal protection via the "Phase Rev" bit in the Starter Fault Enable, Parameter 136. There are no phase reversal fault parameters to configure.

A phase reversal Alarm is also available and enabled via the "Phase Rev" bit in the Starter Alarm Enable, Parameter 137. There are no Alarm parameters to configure.

High and Low Line Power Frequency Protection—Fault and Alarm

The SMC-50 controller can protect against poor line power quality by offering programmable frequency-based protection. You can fault the starter if the line power frequency is either too high or too low.

High and low frequency limits for both Faults and Alarms are configured through the parameters listed in [Table 35](#). Note that each also has a programmable delay to limit nuisance trips.

Frequency Fault (Code 49)

The high/low Frequency Fault, Code 49, is enabled or disabled using the Frequency bit "Freq" in the Starter Fault Enable, Parameter 136.

Frequency Alarm

In addition to the Fault, a Frequency Alarm is also available. The Frequency Alarm is enabled or disabled using the Frequency bit in the Starter Alarm Enable, Parameter 137.

TIP Regardless of the user-defined high or low frequency Fault or Alarm levels, if the line power frequency falls below 45 Hz or rises above 66 Hz, the SMC-50 controller enters a wait state (controller stops and does not start, or does not start if it is already stopped) until the frequency returns to the 45 ...66 Hz range.

Table 35 - High and Low Line Power Frequency Parameter List

Parameter Number	Parameter Name ⁽¹⁾	Minimum/Maximum Value	Default Value	Access	Units
129	Freq High F Lvl	45...66	63	R/W	Hz
225	Freq High F Dly	0.1...99.0	0.1		SECS
130	Freq Low F Lvl	45...66	47		Hz
227	Freq Low F Dly	0.1...99.0	0.1		SECS
131	Freq High A Lvl	45...66	63		Hz
226	Freq High A Dly	0.1...99.0	0.1		SECS
132	Freq Low A Lvl	45...66	47		Hz
228	Freq Low A Dly	0.1...99.0	0.1		SECS

(1) As displayed on the HIM or Connected Components Workbench configuration tools.

Stall Protection—Fault and Alarm

When a motor stalls (stops) during its starting sequence, the motor heats up very rapidly; after some permissible stall time, the motor reaches the temperature limit of its insulation. Rapid stall detection during the starting sequence can extend the motor's life and minimize the potential damage and loss of production.

Stall Fault (Code 24)

When the SMC-50 controller is instructed to start a motor and the programmed start Ramp Time has completed before the motor is Up-to-Speed (UTS), the start sequence continues until one of the following occurs:

- motor reaches full speed,
- Stall Fault, Code 24, occurs,
- indefinitely if the stall fault is disabled, or
- until a motor overload or SCR overtemperature condition

When the stall feature is enabled, the SMC-50 controller starts an internal timer when the programmed Ramp Time expires. When this timer reaches the time value programmed in the Stall Delay, Parameter 188, a Stall Fault is generated. If the Stall Delay parameter is set to zero, then the Fault occurs immediately if the motor is not UTS at the completion of the programmed Ramp Time. If the SMC-50 controller detects that the motor is UTS before the Stall Delay, it considers the start sequence complete, switches to full voltage, and does generate a Stall Fault/Alarm.

TIP Because the beginning of the Linear Speed Starting mode is an open loop voltage control, the actual starting time may vary depending on the motor load. For this reason (and to avoid nuisance faults), the SMC-50 controller automatically adds a time to the configured starting ramp time before the stall timer begins to count. The time factor is 50% of the configured start ramp time.

Enable or disable Stall Fault protection via the "Stall" bit in the Motor Fault Enable, Parameter 230.

Stall Alarm

In addition to the Stall Fault, you can also enable a Stall Alarm, which activates under the same condition as the Stall Fault. In this case, the Alarm is cleared once the motor leaves the starting state (for example, is UTS, is stopped, or faulted).

Enable or disable the Stall Alarm via the "Stall" bit in the Motor Alarm Enable, Parameter 231.

Table 36 - Stall Protection Parameter List

Parameter Number	Parameter Name ⁽¹⁾	Minimum/Maximum Value	Default Value	Access	Units
188	Stall Delay	0.0...30.0	10.0	R/W	SECS

(1) As displayed on the HIM or Connected Components Workbench configuration tools.

Figure 91 - Stall Protection

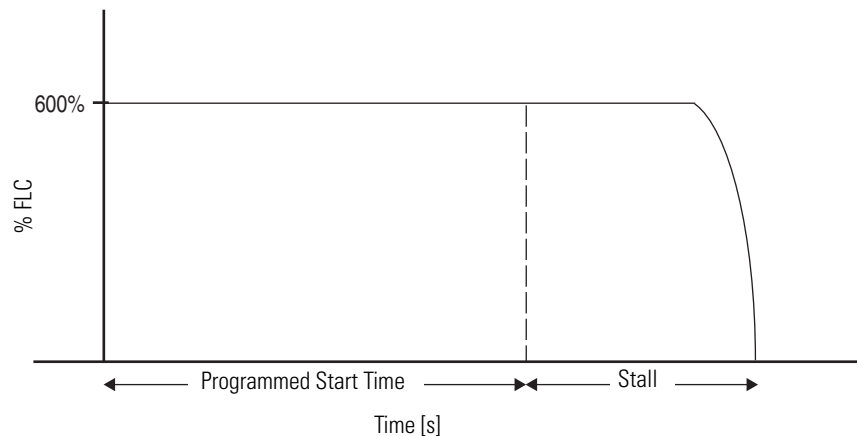

Jam Detection—Fault and Alarm

Motor operational (run) current greater than the motor nameplate rating may indicate a jam condition due to a conveyor jam or jammed drive gear. These conditions can result in overheating of the motor and equipment damage. Rapid Jam detection helps to minimize damage and loss of production.

TIP The SMC-50 starter SCR Overtemperature Fault (see SCR Overtemperature) may occur before the jam trip in the case of high current situations.

Jam Fault (Code 23)

The SMC-50 controller Jam Fault, Fault Code 23, provides detection of a motor jam. A jam condition exists if the motor current rises above a user-defined level for a user-defined time while in the run mode.

TIP This fault is not active during starting or stopping.

The Jam Level, Parameter 114, is a percentage of the motor’s Full Load Current Parameter 78. If the actual motor current rises above the Jam Fault Level (Jam F Lvl) for a time equal to the Jam Fault Delay (Jam F Dly) then a Fault is generated. See [Table 37](#) and [Figure 92](#). Jam protection is enabled or disabled using the Jam bit in the Motor Fault Enable, Parameter 230.

Jam Alarm

In addition to the Fault, a Jam Alarm is also available. Set this up like the Fault Jam, using Jam Alarm Level and Jam Alarm Delay. You can enable or disable this alarm using the Jam bit in the Motor Alarm Enable, Parameter 231.

Table 37 - Jam Detection Parameter List

Parameter Number	Parameter Name ⁽¹⁾	Minimum/Maximum Value	Default Value	Access	Units
78	Motor FLC	1.0...2200.0	1.0	R/W	Amps
114	Jam F Lvl	0...1000	1000		%FLC
115	Jam F Dly	0.1...99.0	0.1		SECS
116	Jam A Lvl	0...1000	1000		%FLC
117	Jam A Dly	0.1...99.0	0.1		SECS

(1) As displayed on the HIM or Connected Components Workbench configuration tools.

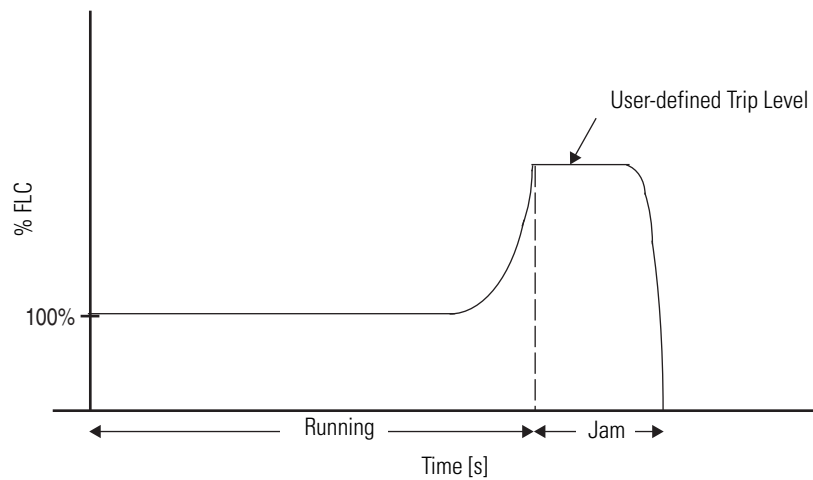
Figure 92 - Jam Detection

Real Power Protection (MWatts)

Motor Over Power Real—Fault and Alarm

Motor Over Power Real Fault (Code 44)

A Motor Over Power Real Fault, Code 44, condition occurs when the real power being consumed by the motor has risen above a user-defined level MWatts Ov F Lvl, Parameter 90, for the user-defined time MWatts Ov F Dly, Parameter 91.

You can enable or disable the over power real Fault by using the MWatts Over bit in the Motor Fault Enable, Parameter 230.

Motor Over Power Real Alarm

A motor overpower real Alarm is also available. Set this up like the motor Fault using Parameter MWatts Ov A Lvl and MWatts Ov A Dly. You can enable or disable this Alarm by using the MWatts Over bit in the Motor Alarm Enable, Parameter 231.

Table 38 - Motor Overpower Real Parameter List

Parameter Number	Parameter Name ⁽¹⁾	Minimum/Maximum Value	Default Value	Access	Units
90	MWatts Ov F Lvl	0.000...1000.00	0.000	R/W	MW
91	MWatts Ov F Dly	0.1...99.0	0.1		SECS
92	MWatts Ov A Lvl	0.000...1000.00	0.000		MW
93	MWatts Ov A Dly	0.1...99.0	0.1		SECS

(1) As displayed on the HIM or Connected Components Workbench configuration tools.

Motor Under Power Real—Fault and Alarm

Motor Under Power Real Fault (Code 43)

A Motor Under Power Real Fault, Fault Code 43, condition occurs when the real power that is being consumed by the motor falls below a user-defined level MWatts Un F Lvl, Parameter 94, for the user-defined time MWatts Un F Dly, Parameter 95.

You can enable or disable this Fault by using the MWatts Under bit in the Motor Fault En, Parameter 230.

Motor Under Power Real Alarm

In addition to the Fault, an Alarm is also available. Set this up like the motor Fault using Parameter MWatts Un A Lvl and MWatts Un A Dly. You can enable or disable this alarm by using the MWatts Under bit in the Motor Alarm En, Parameter 231.

Table 39 - Motor Over Power Real Parameter List

Parameter Number	Parameter Name ⁽¹⁾	Minimum/Maximum Value	Default Value	Access	Units
94	MWatts Un F Lvl	0.000...1000.00	0.000	R/W	MW
95	MWatts Un F Dly	0.1...99.0	0.1		SECS
96	MWatts Un A Lvl	0.000...1000.00	0.000		MW
97	MWatts Un A Dly	0.1...99.0	0.1		SECS

(1) As displayed on the HIM or Connected Components Workbench configuration tools.

Reactive Power Protection (MVAR)

The SMC-50 controller can protect against excessive reactive power (MVAR). You can protect (Fault) or issue a warning (Alarm) if the motor reactive power (MVAR) consumption (+) or generation (-) is too high. You can use this protection with synchronous motors or motors that have active Power Factor correction capacitors.

Motor Over Power Reactive Positive (Motor Consumed)—Fault and Alarm

Motor Over Power Reactive Positive Fault (Code 46)

A Motor Over Power Reactive Positive Fault condition, Fault Code 46, occurs when the reactive power being consumed by the motor rises above a user-defined level +MVAR Ov F Lvl, Parameter 232, for the user-defined delay time +MVAR Ov F Dly, Parameter 233.

You can enable or disable this Fault by using the +MVAR Over bit in the Motor Fault Enable, Parameter 230.

Motor Over Power Reactive Positive Alarm

In addition to the Fault, a Motor Over Power Reactive Alarm is also available. Set this up like the Fault using parameters +MVAR Ov A Lvl and +MVAR Ov A Dly, as shown in [Table 40](#). You can enable or disable the Alarm is by using the +MVAR Over bit in the Motor Alarm Enable, Parameter 231.

Table 40 - Motor Over Power Reactive Positive Parameter List

Parameter Number	Parameter Name ⁽¹⁾	Minimum/Maximum Value	Default Value	Access	Units
232	+MVAR Ov F Lvl	0.000...1000.00	0.000	R/W	MVAR
233	+MVAR Ov F Dly	0.1...99.0	0.1		SECS
234	+MVAR Ov A Lvl	0.000...1000.00	0.000		MVAR
235	+MVAR Ov A Dly	0.1...99.0	0.1		SECS

(1) As displayed on the HIM or Connected Components Workbench configuration tools.

Motor Under Power Reactive Positive (Motor Consumed)—Fault and Alarm

Motor Under Power Reactive Positive Fault (Code 45)

A Motor Under Power Reactive Positive Fault condition, Fault Code 45, occurs when the reactive power being consumed by the motor falls below the user-defined level +MVAR Un F Lvl, Parameter 236, for the user-defined delay time +MVAR Un F Dly, Parameter 237.

You can enable or disable this Fault by using the +MVAR Under bit in the Motor Fault Enable, Parameter 230.

Motor Under Power Reactive Positive Alarm

In addition to the Fault, an Under Power Reactive Alarm is also available. Set this up like the Fault using parameters +MVAR Un A Lvl and +MVAR Un A Dly, as shown in [Table 41](#). You can enable or disable the Alarm by using the +MVAR Under bit in the Motor Alarm Enable, Parameter 231.

Table 41 - Motor Underpower Reactive Positive Parameter List

Parameter Number	Parameter Name ⁽¹⁾	Minimum/Maximum Value	Default Value	Access	Units
236	+MVAR Un F Lvl	0.000...1000.00	0.000	R/W	MVAR
237	+MVAR Un F Dly	0.1...99.0	0.1		SECS
238	+MVAR Un A Lvl	0.000...1000.00	0.000		MVAR
239	+MVAR Un A Dly	0.1...99.0	0.1		SECS

(1) As displayed on the HIM or Connected Components Workbench configuration tools.

Motor Over Power Reactive Negative (Motor Generated)—Fault and Alarm

Motor Over Power Reactive Negative Fault (Code 67)

A Motor Over Power Reactive Negative Fault, Fault Code 67, condition occurs when the Reactive Power being generated by the motor rises above a user-defined level -MVAR Ov F Lvl, Parameter 297, for a user-defined time -MVAR Ov F Dly, Parameter 298. This only occurs when the Reactive Power is negative.

You can enable or disable the Over Power Reactive Negative Fault by using the -MVAR Over bit in the Motor Fault Enable, Parameter 230.

Motor Over Power Reactive Negative Alarm

In addition to the Over Power Reactive Negative Fault, an Over Power Reactive Negative Alarm is also available. Set this up like the Fault, using -MVAR Ov A Lvl, Parameter 299, and -MVAR Ov A Dly, Parameter 300. You can enable or disable this Alarm by using the -MVAR Over bit in the Motor Alarm Enable, Parameter 231.

Table 42 - Motor Over Power Reactive Negative Parameter List

Parameter Number	Parameter Name ⁽¹⁾	Minimum/Maximum Value	Default Value	Access	Units
297	-MVAR Ov F Lvl	0.000...1000.00	0.000	R/W	MVAR
298	-MVAR Ov F Dly	0.1...99.0	0.1		SECS
299	-MVAR Ov A Lvl	0.000...1000.00	0.000		MVAR
300	-MVAR Ov A Dly	0.1...99.0	0.1		SECS

(1) As displayed on the HIM or Connected Components Workbench configuration tools.

Motor Under Power Reactive Negative (Motor Generated)—Fault and Alarm

Motor Under Power Reactive Negative Fault (Code 68)

A Motor Under Power Reactive Negative Fault, Fault Code 68, condition occurs when the Reactive Power being generated by the motor falls below a user-defined level -MVAR Un F Lvl, Parameter 301, for the user-defined time -MVAR Un F Dly, Parameter 302. This only occurs when the Reactive Power is negative.

You can enable or disable the Motor Under Power Reactive Negative Fault by using the -MVAR Under bit in the Motor Fault Enable, Parameter 230.

Motor Under Power Reactive Negative Alarm

In addition to the Motor Under Power Reactive Negative Fault, a Motor Underpower Reactive Negative Alarm is also available. Set this up like the Fault, using -MVAR Un A Lvl, Parameter 303, and -MVAR Un A Dly, Parameter 304. You can enable or disable this Alarm by using the -MVAR Under bit in the Motor Alarm Enable, Parameter 231.

Table 43 - Motor Underpower Reactive Negative Parameter List

Parameter Number	Parameter Name ⁽¹⁾	Minimum/Maximum Value	Default Value	Access	Units
301	-MVAR Un F Lvl	0.000...1000.00	0.000	R/W	MVAR
302	-MVAR Un F Dly	0.1...99.0	0.1		SECS
303	-MVAR Un A Lvl	0.000...1000.00	0.000		MVAR
304	-MVAR Un A Dly	0.1...99.0	0.1		SECS

(1) As displayed on the HIM or Connected Components Workbench configuration tools.

Apparent Power Protection (MVA)

The SMC-50 controller can protect against excessive apparent power. You can protect (Fault) or issue a warning (Alarm) if the apparent power (MVA) consumption of the motor being controlled is too high or too low.

Motor Over Power Apparent—Fault and Alarm

Motor Over Power Apparent Fault (Code 48)

A Motor Over Power Apparent Fault, Fault Code 48, condition occurs when the Apparent Power being consumed by the motor rises above a user-defined level (MVA Ov F Lvl), Parameter 240, for a user-defined time, MVA Ov F Dly, Parameter 241. You can enable or disable this Fault by using the MVA Over Power bit in the Motor Fault Enable, Parameter 230.

Motor Over Power Apparent Alarm

In addition to the Motor Over Power Apparent Fault, a Motor Over Power Apparent Alarm is also available. Set this up like the Fault using MVA Over Alarm Level, Parameter 242, and MVA Over Alarm Delay, Parameter 243. You can enable or disable this Alarm by using the MVA Over Power bit in the Motor Alarm Enable, Parameter 231.

Table 44 - Motor Over Power Apparent Parameter List

Parameter Number	Parameter Name ⁽¹⁾	Minimum/Maximum Value	Default Value	Access	Units
240	MVA Ov F Lvl	0.000...1000.00	0.000	R/W	MVA
241	MVA Ov F Dly	0.1...99.0	0.1		SECS
242	MVA Ov A Lvl	0.000...1000.00	0.000		MVA
243	MVA Ov A Dly	0.1...99.0	0.1		SECS

(1) As displayed on the HIM or Connected Components Workbench configuration tools.

Motor Under Power Apparent—Fault and Alarm

Motor Under Power Apparent Fault (Code 47)

A Motor Under Power Apparent Fault, Fault Code 47, condition occurs when the Apparent Power being consumed by the motor falls below a user-defined time, MVA Un F Lvl, Parameter 244, for a user-defined time, MVA Un F Dly, Parameter 245. You can enable or disable this Fault by using the MVA Under Power bit in the Motor Fault Enable, Parameter 230.

Motor Under Power Apparent Alarm

In addition to the Motor Under Power Apparent Fault, a Motor Under Power Apparent Alarm is also available. Set this up like the Fault using MVA Under Alarm Level, Parameter 246, and MVA Over Alarm Delay, Parameter 242. You can enable or disable this Alarm by using the MVA Under Power bit in the Motor Alarm Enable, Parameter 231.

Table 45 - Motor Under Power Apparent Parameter List

Parameter Number	Parameter Name ⁽¹⁾	Minimum/Maximum Value	Default Value	Access	Units
244	MVA Un F Lvl	0.000...1000.00	0.000	R/W	MVA
245	MVA Un F Dly	0.1...99.0	0.1		SECS
246	MVA Un A Lvl	0.000...1000.00	0.000		MVA
247	MVA Un A Dly	0.1...99.0	0.1		SECS

(1) As displayed on the HIM or Connected Components Workbench configuration tools.

Power Factor Protection

Motor Power Factor (PF)—Fault and Alarm

Lagging Power Factor Under Fault (Code 63)

Leading Power Factor Under Fault (Code 64)

Lagging Power Factor Over Fault (Code 65)

Leading Power Factor Over Fault (Code 66)

Lagging Power Factor Under Alarm

Leading Power Factor Under Alarm

Lagging Power Factor Over Alarm

Leading Power Factor Over Alarm

The SMC-50 controller can protect against an excessive PF for specific applications that require monitoring the phase angle difference between voltage and current. You can protect the motor by using the Fault function or issue a warning using the Alarm function if the PF for an electric motor is either too high or too low for both Leading, Fault Code 64 and 66, and Lagging, Fault Code 63 and 65, conditions.

In addition to the configurable Fault and Alarm levels, both Motor Leading and Motor Lagging Fault and Alarm functions provide a configurable delay time to limit nuisance trips. PF Faults and PF Alarms are individually enabled

and disabled through the Motor Fault Enable, Parameter 230, and Motor Alarm Enable, Parameter 231.

Table 46 - PF Parameter List

Parameter Number	Parameter Name ⁽¹⁾	Minimum/Maximum Value	Default Value	Access	Units
248	Lead PF Ov F Lvl	0...1.00	0	R/W	—
249	Lead PF Ov F Dly	0.1...99.0	0.1		SECS
250	Lead PF Ov A Lvl	0...1.00	0		—
251	Lead PF Ov A Dly	0.1...99.0	0.1		SECS
252	Lead PF Un F Lvl	0...1.00	0		—
253	Lead PF Un F Dly	0.1...99.0	0.1		SECS
254	Lead PF Un A Lvl	0...1.00	0		—
255	Lead PF Un A Dly	0.1...99.0	0.1		SECS
256	Lag PF Ov F Lvl	0...1.00	0		—
257	Lag PF Ov F Dly	0.1...99.0	0.1		SECS
258	Lag PF Ov A Lvl	0...1.00	0		—
259	Lag PF Ov A Dly	0.1...99.0	0.1		SECS
260	Lag PF Un F Lvl	0...1.00	0		—
261	Lag PF Un F Dly	0.1...99.0	0.1		SECS
262	Lag PF Un A Lvl	0...1.00	0		—
263	Lag PF Un A Dly	0.1...99.0	0.1	SECS	

(1) As displayed on the HIM or Connected Components Workbench configuration tools.

Excessive Starts/Hour Protection

Motor Starts/Hour—Fault and Alarm

Starts per Hour Fault (Code 29)

You can program the SMC-50 controller to limit the maximum number of starter/motor starts within a sliding one-hour time window. Once the number of starts per hour is reached as you have configured it in Starts Per Hour, Parameter 128, any additional starts will cause an Excessive Starts Fault, Fault Code 29. You can enable or disable this Fault by using the Starts/Hr bit in the Motor Fault Enable, Parameter 230.

Starts per Hour Alarm

A Starts Per Hour Alarm is also available. You can enable or disable this Alarm by using the Starts/Hr bit in the Motor Alarm Enable, Parameter 231. The Starts per Hour Faults and Alarm is activated when the starts within the last hour exceed the value configured in Starts Per Hour, Parameter 128. The starts count value is cleared when the starts in the previous hour are less than or equal to the Starts Per Hour parameter.

Table 47 - Starts per Hour Parameter List

Parameter Number	Parameter Name ⁽¹⁾	Minimum/Maximum Value	Default Value	Access	Units
128	Starts Per Hour	1...99	99	R/W	—

(1) As displayed on the HIM or Connected Components Workbench configuration tools.

Preventive Maintenance Protection

Preventive Maintenance (PM) Hours Protection—Fault and Alarm

PM Hours Fault (Code 50) and Alarm

You can configure the SMC-50 controller to provide a Fault and/or Alarm to indicate that PM should be performed after a programmed number of hours have elapsed, Fault Code 50. Do this by setting a value in the Time to PM, Parameter 21, to indicate the amount of running time before PM needs to be done.

The programmed Time to PM value counts down while the motor is starting, stopping, operating in slow speed, and running. When the Time to PM parameter value reaches zero, the configured Fault and/or Alarm condition is activated and the parameter counter stops decrementing.

After the preventive maintenance is complete, you can reset the Fault and/or Alarm. You must reload the Time to PM to the value configured and stored in the PM Hours, Parameter 126, through the Meter Reset, Parameter 16, via the HIM or network connection.

Enable the PM Hours Fault by using the PM Hours bit in the Motor Fault Enable, Parameter 230. The PM Hours Alarm is enabled using the PM Hours bit in the Motor Alarm Enable, Parameter 231.

Table 48 - PM Hours Protection Parameter List

Parameter Number	Parameter Name ⁽¹⁾	Minimum/Maximum Value	Default Value	Access	Units
126	PM Hours	1 ... 10000	10000	R/W	HRS
21	Time to PM	0.0 ... 10000.00	0.0	R	HRS
16	Meter Reset	Ready, Elapsed Time, Energy, Time to PM, Starts to PM	Ready	R/W	—

(1) As displayed on the HIM or Connected Components Workbench configuration tools.

PM Starts Protection—Fault and Alarm

PM Starts Fault (Code 51) and Alarm

You can configure the SMC-50 controller to provide a Fault and/or Alarm to indicate that PM should be performed after a pre-defined number of starts have occurred, Fault Code 51. Do this by using the PM Starts, Parameter 127, Starts to PM, Parameter 22, and Meter Reset, Parameter 16.

The Starts to PM parameter indicates the number of starts before preventive maintenance needs to be performed. This value counts down by one for each start initiated, even if the start is not completed. When the Starts to PM value reaches zero, the configured Fault and/or Alarm condition activates and the counter stops counting.

After the preventive maintenance is complete, you can reset the Fault and/or Alarm. You must reload the Starts to PM to the value configured and stored in the PM Starts parameter through the Meter Reset, Parameter 16 via a HIM or network communications.

The PM Starts Alarm function is enabled using the PM Starts bit in the Motor Fault Enable, Parameter 230. The Alarm is enabled using the PM Starts bit in the Motor Alarm Enable, Parameter 231.

Table 49 - Starts Protection Parameter List

Parameter Number	Parameter Name ⁽¹⁾	Minimum/Maximum Value	Default Value	Access	Units
127	PM Starts	1...50000	100	R/W	
22	Starts to PM	0...50000	0	R	
16	Meter Reset	Ready, Elapsed Time, Energy, Time to PM, Starts to PM	Ready	R/W	

(1) As displayed on the HIM or Connected Components Workbench configuration tools.

Line Loss Protection

Line Loss Fault Phase A (Code 1)

Line Loss Fault Phase B (Code 2)

Line Loss Fault Phase C (Code 3)

The SMC-50 controller can individually identify and provide a Fault and or Alarm if a power line loss occurs on any phase.

TIP Phase A, B, or C loss = Fault Code 1, 2, or 3 respectively. There are no line loss Fault Parameters to configure.

The Line Loss Fault is enabled or disabled using the Line Loss bit in the Starter Fault Enable, Parameter 136. In addition, a Line Loss Alarm can be enabled or disabled using the Line Loss bit in the Starter Alarm Enable, Parameter 137.

TIP If Line Loss is disabled, consider enabling the Undervoltage Fault to limit potential motor damage caused by phase loss.

Silicon-Controlled Rectifier (SCR) Protection

Shorted SCR Fault—Phase A, B, or C

Shorted SCR Fault Phase A (Code 4)

Shorted SCR Fault Phase B (Code 5)

Shorted SCR Fault Phase C (Code 6)

The SMC-50 controller can detect whether any one of its SCRs are shorted in any phase. The shorted SCR Fault is always enabled (user cannot disable). No user intervention or parameter configuration is required and no shorted SCR Alarm exists.

TIP Shorted SCR detection is performed as part of a prestart check.

SCR Overtemperature—Fault

SCR Overtemperature Fault (Code 10)

The SMC-50 controller can detect whether any one of its SCRs has reached an over temperature condition, which could indicate excessive current draw or excessive number of starts. This function is accomplished using an I^2t calculation. There are no SCR overtemperature parameters for you to configure. The SCR Overtemperature Fault is always enabled. There is no SCR Overtemperature Alarm.

The SCR temperature calculation/algorithm also controls the cyclic operation of the SMC-50 controller's fan(s) in the power section. The internal fan of the solid-state SMC-50 controller turns on whenever the motor that it is controlling is running **or** the estimated SCR temperature is above 50 °C. The fan turns off when the motor is **not** energized **and** the estimated SCR temperature is below 49 °C.

For SMC-50 controllers with internal bypass, you can wire the fans directly to the power source. In this case, the fans run all of the time. You could also wire an auxiliary to control the fans. Fan control is selected and then the fans are controlled in the same manner as with the solid-state units.

Open SCR Gate Fault and Alarm—Phase A, B, or C

Open SCR Phase A (Code 7)

Open SCR Phase B (Code 8)

Open SCR Phase C (Code 9)

The SMC-50 controller can detect whether an SCR control gate in any power phase has malfunctioned and initiate a Fault or Alarm. There are no user-configurable Open Gate parameters.

The Open SCR Gate Fault is enabled and disabled using the Open Gate bit in the Starter Fault Enable, Parameter 136. The Open SCR Gate Alarm is enabled and disabled in the Starter Alarm Enable, Parameter 137.

Open Bypass—Phase A, B, or C

Open Bypass Phase A (Code 13)

Open Bypass Phase B (Code 14)

Open Bypass Phase C (Code 15)

The SMC-50 controller monitors the power pole bypass contacts for proper operation. If a contact closure is not sensed, the SMC-50 controller will indicate an open bypass fault in the appropriate phase.

Power Quality

Power Quality Fault and Alarm—Phase A, B, or C

Power Quality Phase A (Code 52)

Power Quality Phase B (Code 53)

Power Quality Phase C (Code 54)

A power quality Fault or Alarm occurs when the starter is not properly firing its phase A, B, or C SCRs. This condition is generally attributed to power line problems that are not detected by other line monitoring functions. There are no user-configurable Power Quality Fault or Alarm parameters to configure.

Phase A, B, and C Power Quality equates to Fault Code 52, 53, or 54 respectively. You can enable or disable this by using the Power Quality bit in the Motor Fault Enable, Parameter 230.

You can also enable or disable a Power Quality Alarm by using the Power Quality bit in the Motor Alarm Enable, Parameter 231.

Total Harmonic Distortion (THD) Fault and Alarm

Power Quality THDV (Fault Code 55) and Power Quality THDI (Fault Code 56)—Fault and Alarm

The SMC-50 controller lets you read power line THD which is the average of 32 line frequency harmonics. The calculation for THDI and THDV (THD_x) is:

$$\text{THD}_x = \sqrt{\frac{(\text{THD}_2^2 + \text{THD}_3^2 \dots \text{THD}_{31}^2)}{\text{THD}_1}}$$

Excessive THD indicates a problem in the power source and/or the application. This can have an adverse effect on the performance of the overall system. THD Fault and Alarm parameters are available for both voltage THDV and current THD I. A Fault and Alarm delay time and a level are also available to configure each of these parameters.

Table 50 - THD Parameter List

Parameter Number	Parameter Name ⁽¹⁾	Minimum/Maximum Value	Default Value	Access	Units
118	THD V F Lvl	0.0...1000.0	1000.0	R/W	%
119	THD V F Dly	0.1...99.0	0.1		SECS
120	THD V A Lvl	0.0...1000.0	1000.0		%
121	THD V A Dly	0.1...99.0	0.1		SECS
122	THD I F Lvl	0.0...1000.0	1000.0		%
123	THD I F Dly	0.1...99.0	0.1		SECS
124	THD I A Lvl	0.0...1000.0	1000.0		%
125	THD I A Dly	0.1...99.0	0.1		SECS

(1) As displayed on the HIM or Connected Components Workbench configuration tools.

Power Pole Overtemperature—Fault

PTC Power Pole Overtemperature Fault (Code 60)

A built-in PTC is used to measure the SMC-50 controller's power pole temperature. The SMC-50 controller generates a Power Pole PTC Fault, Fault Code 60, when the temperature in the power pole rises above the PTC trip temperature.

TIP There are no user-configurable Power Pole Overtemperature Fault parameter you cannot disable it. You cannot reset the Fault until the unit cools.

Open Load—Fault and Alarm

No Load Motor Fault (Code 14)

Open Motor Phase A Loss Fault (Code 15)

Open Motor Phase B Loss Fault (Code 16)

Open Motor Phase C Loss Fault (Code 17)

The SMC-50 controller can detect and report a No Load Motor Fault (no motor detected), Fault Code 14, condition and Open Motor Phase Loss Fault condition for each individual motor phase A, B, or C, Fault Code 15, 16, and 17. A check for No Load and Open Motor Phase is done as an SMC-50 controller pre-start activity and is checked immediately after the motor start command and before the first SCR gating pulse. There are no user-configurable parameters associated with this Fault.

You can enable or disable the No Load and Open Motor Phase Loss Fault by using the Open Load bit in the Motor Fault Enable, Parameter 230.

You can also enable or disable an Open Load Alarm by using the Open Load bit in the Motor Alarm Enable, Parameter 231.

Current Transformers (CT) Loss—Fault

CT Loss Phase A Fault (Code 30)

CT Loss Phase B Fault (Code 31)

CT Loss Phase C Fault (Code 32)

The CT Loss Fault is provided on a per phase basis (phase A, B, and C; Fault Code 30, 31, and 32) and occurs when the current feedback signal from one of the SMC-50 controller's internal CTs is invalid. Indication of an invalid CT feedback signal is when the SMC-50 controller remains at the minimum negative current or maximum positive current for its current range. This Fault cannot be disabled and no parameters need to be configured.

Locked Rotor—Fault and Alarm

Locked Rotor Fault (Code 70)

The Locked Rotor Fault, Fault Code 70, provides indication that the rotor of the motor under SMC-50 controller control and operating in **any** running mode (for example, Slow Speed) has become frozen or locked.

TIP The Locked Rotor Fault is similar to the Jam Fault except it is active during all running modes, not just at full speed.

The value or level of the Locked Rotor Fault is configured as a percentage of the motor FLC using Locked Rotor F Lvl, Parameter 84. A configurable delay time using Locked Rtr F Dly, Parameter 85, is also available to help eliminate nuisance Faults.

Locked Rotor protection is enabled or disabled via the Locked Rotor bit in the Motor Fault Enable, Parameter 230.

You can also enable a Locked Rotor Alarm that will activate under the same condition as the Locked Rotor Fault. The Locked Rotor Alarm is enabled or disabled via the Locked Rotor bit in the Motor Alarm Enable, Parameter 231,

Table 51 - Locked Rotor Parameter List

Parameter Number	Parameter Name ⁽¹⁾	Minimum/Maximum Value	Default Value	Access	Units
84	Locked Rtr F Lvl	400...1000	600	R/W	% FLC
85	Locked Rtr F Dly	0.1...100.0	0.1		SECS
310	Locked Rtr A Lvl	400...1000	600		% FLC
311	Locked Rtr A Dly	0.1...100.0	0.1		SECS

(1) As displayed on the HIM or Connected Components Workbench configuration tools.

Expansion Module Functions **Expansion Device Removed Fault**

Expansion Module Removed Fault (Code x026)

When an expansion module (for example, 150-SM...) is removed from a powered down control module and power is reapplied, Expansion Removed, Fault Code 26, is generated. For SMC-50 controller expansion modules, the Fault code includes the control module port number (7, 8, or 9) to distinguish which expansion module caused the Fault (for example, an expansion module located in port 8 would display the Fault Code 8026).

For physical DPI devices that support this function, the Fault is generated only when the associated bit is set in the Logic Mask Act, Parameter 149.

IMPORTANT Ensure all line and control power is removed from the SMC-50 controller before you remove or install any expansion or communication module.

Expansion Device Fault

Expansion Module Fault (Code x028)

This fault code is generated directly by any option module or DPI device and is separate from the Expansion Device Removed fault (control module generated). This fault is always enabled (user cannot disable) in the control module. Individual option modules or DPI devices may enable or disable these faults as needed.

TIP Not all devices use this fault.

Expansion Module Incompatible Fault

Incompatible Expansion Module Fault (Code x027)

If an expansion module (for example, 150-SM...) is plugged into an incompatible expansion port or the expansion module is not supported by the control module firmware revision (FRN), an Expansion Incompatible, Fault Code 27, is generated. The SMC-50 controller port number (7, 8, or 9) of the expansion module generating the Fault is also displayed (for example, an expansion module located in port 7 would display the Fault Code 7027). This fault cannot be disabled.

Real Time Clock (RTC)

Battery Low

RTC Battery Low Alarm (Code 69)

An RTC Battery Low, Alarm Code 69, provides indication of a control module battery low condition. This condition is checked upon power up of the control module. The battery maintains the operation of the control module's RTC when the control power is removed. Once the Alarm is posted, the battery should be replaced as soon as possible. This alarm cannot be disabled.

To clear this alarm, you must replace the battery and set the time/date by using a HIM or applicable PC software (for example, Connected Components Workbench software). For battery replacement instructions, please see [Appendix D](#).

Configuration Functions

Configuration Change—Fault and Alarm

Configuration Change Fault (Code 57)

By setting the Configuration Change bit in the Starter Fault Enable, Parameter 136, any change to the controller configuration will result in a Configuration Change Fault, Fault Code 57. An Alarm can also be initiated by setting the "Config Change" bit in the Starter Alarm Enable, Parameter 137. The Fault can be cleared immediately and the Alarm clears upon the next motor start command.

I/O Configuration—Fault

I/O Configuration Fault (Code 61)

The SMC-50 controller generates an I/O Configuration Fault, Fault Code 61, if any control input is programmed as a Start or Slow Speed command and no input is configured for Coast or Stop. The Fault occurs when the Start or operational maneuver is attempted (the motor will not start). This Fault is also generated when an input configuration changes from:

1. one that cannot start the motor to one that can start the motor **OR**
2. an input that can stop the motor to one that cannot.

This Fault is always enabled; no parameter adjustments are required and no alarm is available.

Buffers and Storage Functions

Non-volatile Storage (NVS) Fault

NVS Fault (Code 34)

The NVS Error Fault, Fault Code 34, is posted if a read/write checksum error occurs within the user data portion of the SMC-50 controller's non-volatile memory. This Fault can only be cleared if you modify/store a parameter value (this requires changing any parameter). It is recommended that you perform a Load Defaults command to make sure that all controller parameters are within range. you cannot clear this error by cycling the SMC-50 controller power.

Fault Buffer and Fault Storage Parameters

The Fault Buffer is used to store the last five system Faults. The Fault Buffer is accessed via the Diagnostic screen of a 20-HIM-A6, 20-HIM-C6S, or from the Device Properties screen, which you access via the Connected Components Workbench software. The most recent Fault is located at the top of the buffer

(number 1 for the HIM or number 1.1 for the software configuration tool. The Fault Buffer also stores the date and time that the Fault occurred.

TIP The date and time information is obtained from the SMC-50 controller's RTC. Ensure the RTC is set correctly.

The five most recent Faults are stored in Parameter 138 through Parameter 142. any networked device can access this stored Fault history in the parameter list. The Fault date and time are not available from the parameters list.

Table 52 - Fault Buffer and Fault Storage Parameter List

Parameter Number	Parameter Name ⁽¹⁾	Fault Code	Access	Units
138	Fault 1	0-10000	R	—
139	Fault 2			
140	Fault 3			
141	Fault 4			
142	Fault 5			

(1) As displayed on the HIM or Connected Components Workbench configuration tools.

Alarm/Event Buffer and Alarm/Event Storage Parameters

In addition to storing (buffering) Alarm Data, the Alarm Buffer is used to store several key controller events. The type of events stored includes:

Event	Alarm Code
Start	71
Slow Speed	72
Stop Option	73
Coast	74
Clear Fault	75—a Fault has been cleared
Fault	76
Parameter Change	77—change to any Parameter occurred

You can access the Alarm Buffer via the Diagnostic screen of a 20-HIM-A6, 20-HIM-C6S, or from the Device Fault/Alarm button of Connected Components Workbench software. The last 100 events are stored in the Alarm Buffer with the most recent event numbered as 1 (HIM) or 1.1 (software) in the list. Along with the Alarm Code, the date and time that the event occurred are also listed.

TIP The date and time information is obtained from the SMC-50 controller's RTC. Ensure that the RTC is set correctly.

In addition to the Alarm Buffer, the last five Alarm Events are available via Parameter 143 through Parameter 147. Storing this Alarm history in the parameter list provides access by any networked device. The Alarm/Event date and time are not available from the parameter list.

Table 53 - Alarm/Event Parameter List

Parameter Number	Parameter Name ⁽¹⁾	Alarm Code	Access	Units
143	Alarm 1	0-10000	R	—
144	Alarm 2			
145	Alarm 3			
146	Alarm 4			
147	Alarm 5			

(1) As displayed on the HIM or Connected Components Workbench configuration tools.

Auto Restart from Fault Function

This function allows the SMC-50 controller to automatically restart from various Starter or Motor Fault conditions. Auto Restart from Fault is individually bit enabled or disabled using Starter Restart Enable, Parameter 135, or Motor Restart Enable, Parameter 264. See [Table 54 on page 154](#).

Parameter 133, Restart Attempts, lets you define the allowable number of restart attempts from the fault before ending the retry process. The Retry Counter clears whenever the controller receives a valid Stop command.

In addition, Restart Delay Time, Parameter 134, lets you define a time delay from when the Fault event occurred until a Restart Attempt can be effective.

TIP This delay is not used with an Overload Fault. Instead, the restart attempt occurs when the Mtr Therm Usage, Parameter 18, falls below the OL Reset Level, Parameter 80.

Table 54 - Auto Restart from Fault Parameter List

Parameter Number	Parameter Name ⁽¹⁾	Fault Name	Bit Assignment	Bit Access	Units
135	Strtr Restart En	Volt Umbal	0	R/W	Bit = 0, Disabled Bit = 1, Enabled [All Disabled as Default]
		Overvoltage	1		
		Undervoltage	2		
		Phase Rev	3		
		Line Loss	7		
		Open Gate	5		
		Config Change	6		
		Freq	7		
THD V	8				
264	Motor Restart En	Overload	0	R/W	Bit = 0, Disabled Bit = 1, Enabled [All Disabled as Default]
		Underload	1		
		MWatts Over	2		
		MWatts Under	3		
		+MVAR Over	7		
		+MVAR Under	5		
		-MVAR Over	6		
		-MVAR Under	7		
		MVA Under	8		
		MVA Over	9		
		Curr Imbal	10		
		Jam	11		
		Stall	12		
		Starts/Hr	13		
		PM Hours	14		
		PM Starts	15		
		Power Qual	16		
		Open Load	17		
		THD I	18		
		Lead PF Un	19		
		Lead PF Ov	20		
		Lag PF Un	21		
		Lag PF Ov	22		
Locked Rotor	23				

(1) As displayed on the HIM or Connected Components Workbench configuration tools.

Table 55 - Auto Restart Parameter List

Parameter Number	Parameter Name ⁽¹⁾	Minimum/Maximum Value	Default Value	Access	Units
133	Restart Attempts	0...5	0	R/W	
134	Restart Dly	0...60	0		SECS

(1) As displayed on the HIM or Connected Components Workbench configuration tools.

Programming

Overview

This chapter provides a basic understanding of the programming/configuration tools available to modify the SMC-50 controller's parameters. Unlike previous SMC products (for example, SMC-3 and SMC Flex), the SMC -50 controller does not contain a built-in programming tool. This lets you select from several programming tools to best suit your application.

Human Interface Module (HIM) (Cat. No. 20-HIM-A6 or 20-HIM-C6S)

The 20-HIM-A6 lets you:

- configure/monitor all controller parameters,
- configure/monitor all option modules (for example, 150-SM4, digital I/O, 150-SM6 PCM, etc.), and
- use the SMC-50 controller's general startup configuration wizard.

TIP The 20-HIM-A3 cannot configure the option modules or use the general startup configuration wizard. Therefore, the 20-HIM-A3 is not recommended for use with the SMC-50 controller and is not mentioned in this document.

The 20-HIM-A6 is typically inserted into the HIM bezel port located on the upper right of the control module. Inserting the HIM into the bezel provides operation in a NEMA Type 1 environment. The 20-HIM-C6S, a remote (door-mount) version of the 20-HIM-A6, provides operation in a NEMA 4X/12 environment and includes a 1202-C30 interface cable to the SMC-50 controller DPI Port 2 on the top of the controller. For additional information on mounting the 20-HIM-A6 or the 20-HIM-C6S, see the HIM user manual, publication [20HIM-UM001](#).

Figure 93 - HIM Mounting Locations

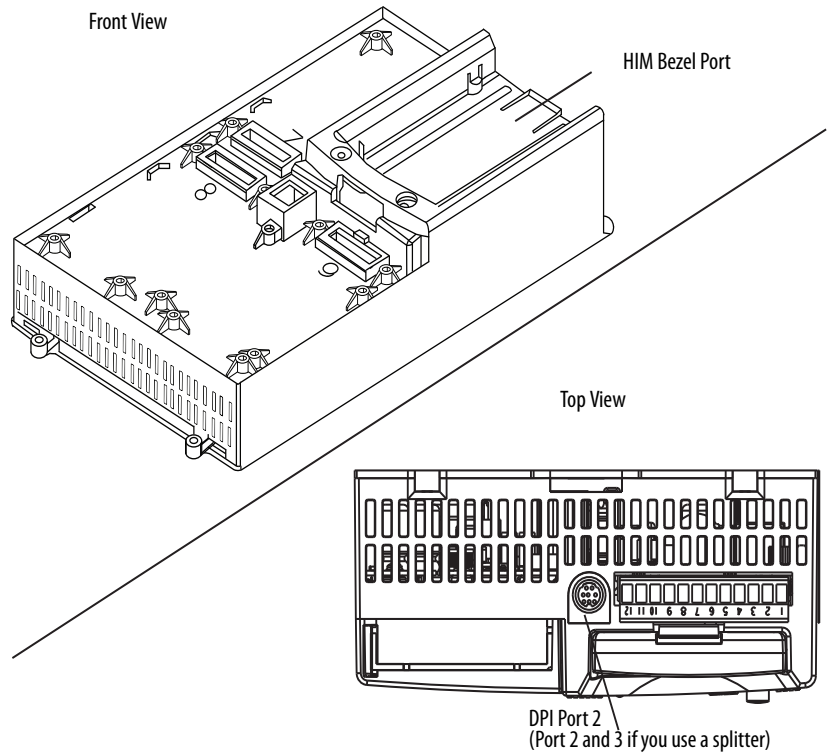

The following information describes some of the basic screens and keypad functions of the 20-HIM-A6 or 20-HIM-C6S. Additional details about all HIM functions can be found in the user manual, publication [20HIM-UM001](#).

HIM Single-Function Keys

The four single-function keys only perform their dedicated functions no matter which screen or data entry mode you are using.

Table 56 - HIM Single-Function Keys

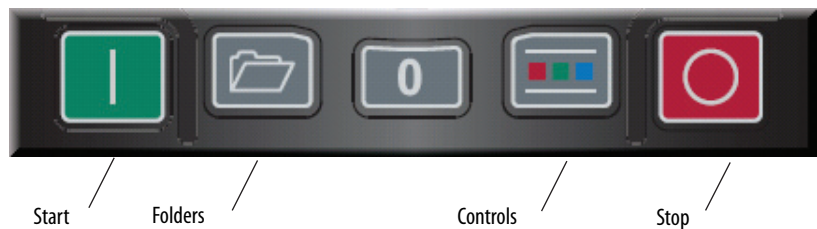



Key	Function
Start	Starts the controller if the SMC-50 controller Logic Mask is enabled for the port the HIM is connected to. ⁽¹⁾
Folders	Accesses folders for parameters, diagnostics, memory functions, preferences, and other tests.
Controls	Accesses jog, direction, auto/manual, and other control functions.
Stop	Stops the SMC-50 controller or clears a fault. The Stop key is always active. Coast Stop only.

(1) If the device (port) is enabled and removed under power or an expansion device is removed, a fault is generated. The bit location (for example, 0, 1, 2, etc.) corresponds to the DPI port numbers.

HIM Soft Keys

Up to five dynamic soft keys can be shown at the bottom of the HIM screen. Based on the specific screen or the data entry mode being used, a soft key name and its function may change. When a soft key is active, its presentation function and corresponding soft key label are shown at the bottom of the HIM screen.

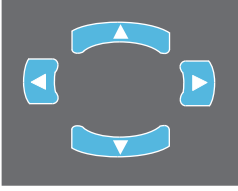
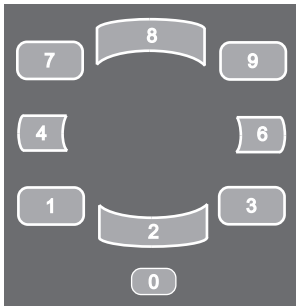
Table 57 - HIM Soft Key Functions

Soft Key	Description	Function
	Multi-Function—Blue	<ul style="list-style-type: none"> • Scrolls through menus and screens as directed by each arrow • Performs corresponding functions displayed in the data area
	Numeric Keys—Grey	<ul style="list-style-type: none"> • Enters their respective numeric values
	5/Enter	<ul style="list-style-type: none"> • Enters the numeric value, 5 • Displays the next level of a selected menu item • Enters new values • Performs intended actions

Password Modification Using the HIM

The SMC-50 controller provides password protection by numeric code (0...65,535) to prevent unwanted modification of parameters. You can view or monitor data and parameter values without entering the password, but modification requires password entry.

The password can be modified from the PROPERTIES folder screen of the 20-HIM-A6 or 20-HIM-C6S, as shown in [Figure 94](#).

Figure 94 - PROPERTIES Folder Screen



TIP If the default password (0=default) is modified, ensure the modified password is written down in a secure place. There is no way to reset the password if it is forgotten. For additional information on password modification, see the 20-HIM-A6 user manual, publication [20HIM-UM001](#).

To modify the default password, perform the following steps using the 20-HIM-A6 or 20-HIM-C6S:

1. From the initial power-up screen, press the FOLDERS single function key.
2. Use the forward or back arrow key until the PROPERTIES folder screen is displayed, as shown in [Figure 94](#).
3. Select the CHANGE PASSWORD option, then press the Enter (#5) key.
4. Enter a numeric password, then press the Enter (#5) key. This will load the password into the SMC-50 controller's memory.

Parameter Access Level Modification Using the HIM

The SMC-50 controller provides three different parameter access levels: Monitor, Basic, and Advanced. These access levels let you limit user access and/or speed viewing or changing of certain parameters.

- TIP**
- The access level is **not** maintained if power to the controller is cycled.
 - The default access level is Basic.
 - The advanced level provides access to all parameters.
 - Individual parameter access levels are shown in [Table 69](#) through [Table 73](#) beginning on [page 181](#) and is also contained in the Parameter Linear List, [Table 74](#) through [Table 78](#) beginning on [page 184](#).

To view/modify the current access level, perform the following steps using the 20-HIM-A6:

1. From the initial power-up screen, press the FOLDERS single function key.
2. Press the forward or back arrow key until the DEV PARAM folder screen appears.
3. Select the PARAM ACCESS LEVEL option, then press the Enter (#5) key. The Dev Parameter screen appears.

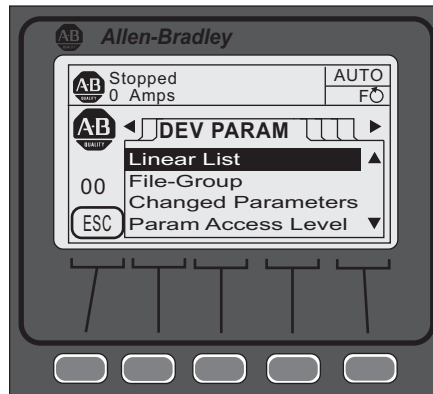

4. Use the up or down arrow to scroll up or down until you reach the desired access level
5. Press Enter (#5) to view that access level.

Parameter Management

Before you begin programming, it is important to understand how the memory is structured within the SMC-50 and used on power-up and during normal operation.

Figure 95 - Memory Block Diagram

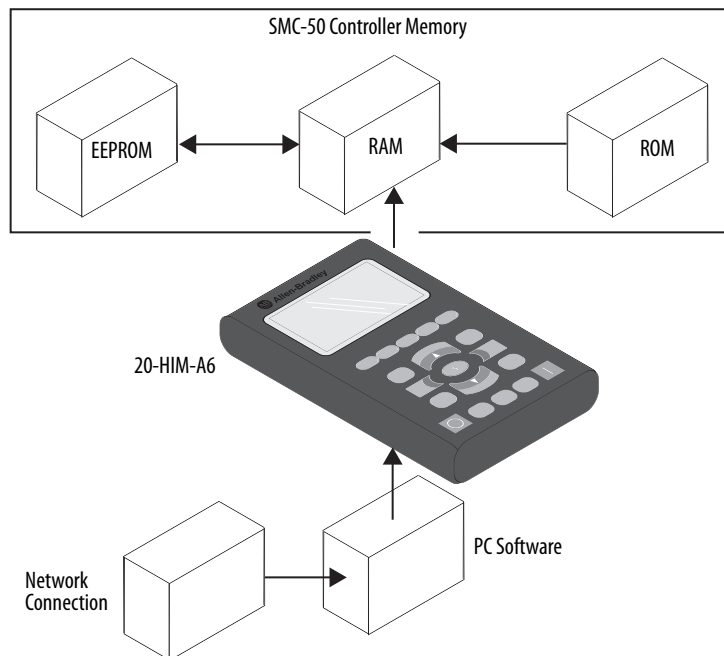

RAM (Random Access Memory)

RAM is the work area of the controller after it is powered up. The SMC-50 controller uses an Auto Store feature when programming parameters. When parameters are modified in the program mode, the new values are stored immediately in RAM and then in EEPROM (Electrically Erasable Programmable Read-only Memory), once the enter key has been pressed. If control power is lost before the enter key is pressed, these values are lost. When the device powers up, it copies the values from the EEPROM area of memory into RAM.

ROM (Read-only Memory)—Set Defaults

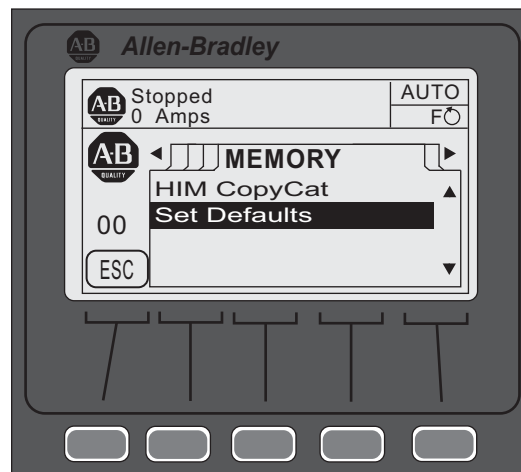

The SMC-50 controller comes with factory default parameter values. These settings are stored in non-volatile ROM and are displayed the first time you enter the Program mode via the Linear List or File-Group mode using the HIM. To restore factory parameter defaults:

1. Navigate to the Memory folders screen with Port <00> displayed.

TIP Option modules can also be restored to defaults using this method. Ensure its respective port number is displayed.

2. Select/highlight the Set Defaults line, then press ENTER (#5). The following text is displayed: WARNING: Sets all Parameters to factory defaults. Continue?
3. Press the ENTER soft key to change defaults or the ESC soft key to return to the previous screen.

TIP You can also restore factory defaults by using the Parameter Management, Parameter 229, available in the Utility File-Group.

EEPROM

The SMC-50 controller provides a non-volatile area for storing user-modified parameter values in the EEPROM.

Parameter Configuration

Using the START UP Configuration Tool (20-HIM-A6 or 20-HIM-C6S)

The general START UP configuration tool lets you rapidly configure an SMC-50 controller. Enabled by the SMC-50 controller and the 20-HIM-A6 or 20-HIM-C6S, a series of questions required to configure starting (for example, Soft, Linear, Pump, etc.) and stopping (for example, Coast, Pump, etc.) modes are displayed on the HIM via this tool.

Not all parameters are configured with this tool. You can configure any non-configured startup parameters by using the parameter number or File—Group search method. See [Basic Configuration using the HIM on page 189](#).

Accessing the General START UP Tool

1. Select the FOLDERS single-function key located on the lower left portion of the keypad.
2. Use the left or right arrow key until the START UP folders screen is displayed

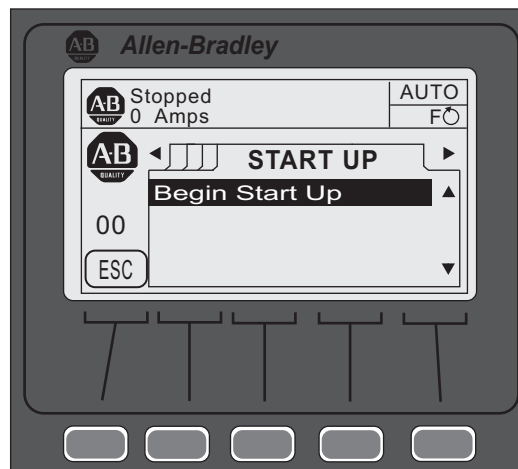

3. Press the ENTER (#5) key to begin the configuration process. The HIM displays "Run General Start-up?".
4. Press the Yes soft key to begin the process or Abort soft key to return to the START UP folders screen.



The HIM displays a series of questions about the Motor, Start, and Stop processes.

TIP Depending on the answers to the Start and Stop processes, some screens may not be displayed.

EXAMPLE

If: Soft Start, Linear Speed, or Pump Start is selected:

Then: Starting Torque, Max Torque, Rated Torque, and Rated Speed will not be displayed.

Reason: These parameters are specific to the Torque Start parameter group.

Entering Data into General Startup

1. Display the parameter.

If the HIM provides the allowable range (for example, 1.0 << 2200.0) at the bottom of the screen, enter the data value. If an up or down arrow soft key is displayed, use the soft key to display the desired selection.

Enter the data value if you see this screen

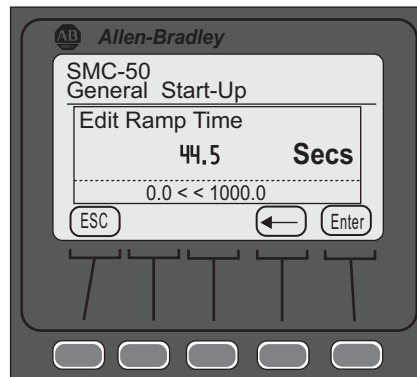

Use the up and down arrows or soft keys to display your selection if you see this screen



2. Enter the desired value, then press the ENTER soft key.

TIP If you enter an incorrect value: Press the ESC soft key to return to the previous screen, then enter the desired value. Use the left arrow soft key to delete a single digit at a time from the data field to enter the correct digit. If a group of selections is displayed, the left arrow soft key moves to the lowest numbered selection.

Once all parameters are entered, the START-UP folders screen appears.

Review/Modify Parameter Data

1. Display the START UP folder screen.
2. Press the ENTER (#5) key.
3. Select the "Yes" soft key when "Run General Start-Up?" is displayed.
4. Individually review each parameter (required), pressing the ENTER soft key to move onto the next parameter. If necessary, press the ESC soft key to review the previous parameter.

TIP To modify parameter data, use the procedure outlined in [Entering Data into General Startup on page 162](#).

Figure 96 - Flow Chart—General Startup Parameters

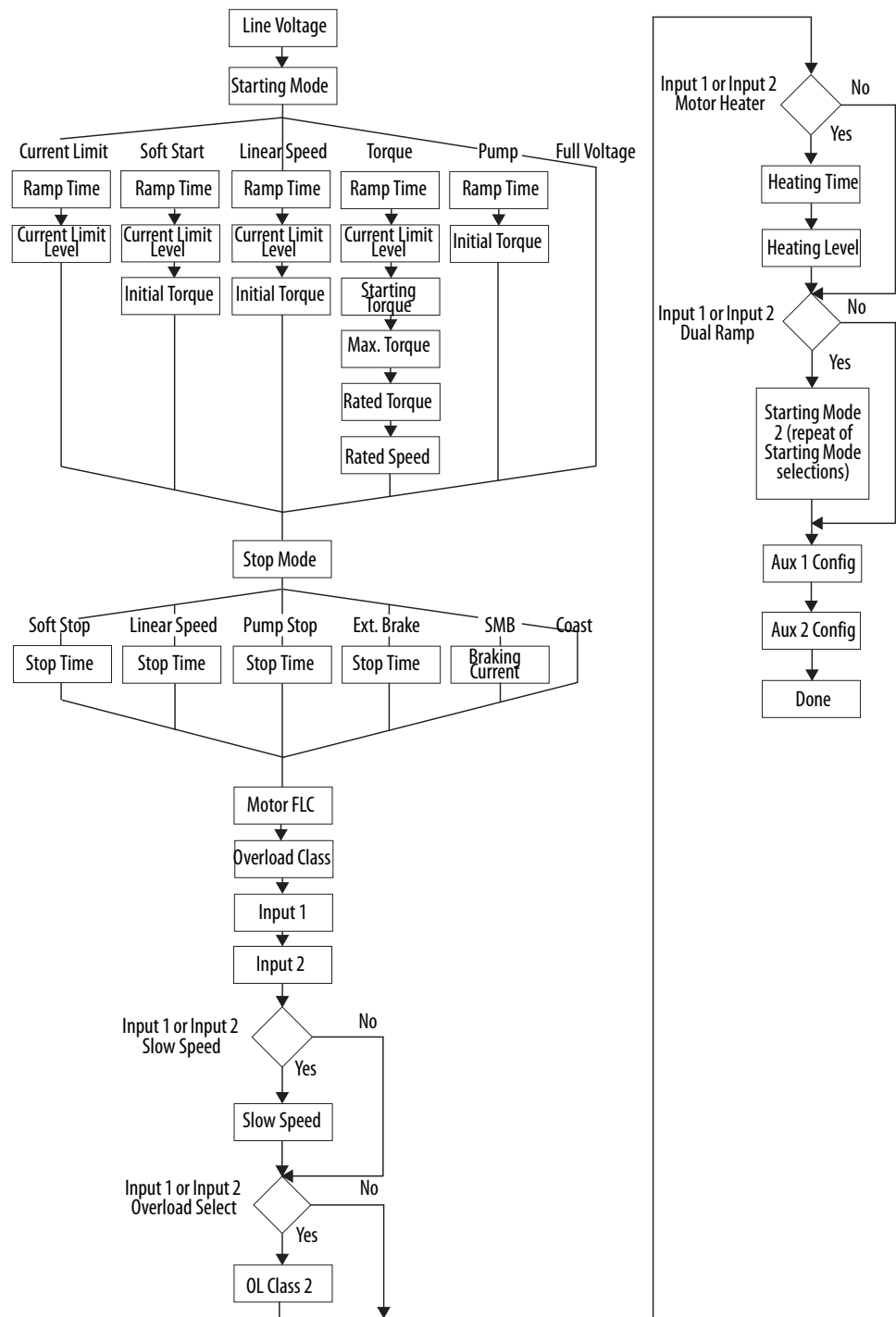

Parameter Search and Configuration

The 20-HIM-A6 or 20-HIM-C6S modules can access all of the SMC-50 controller parameters. These modules provide two basic ways to search for and modify a specific parameter or group of parameters: by parameter number or

File-Group. The following example explains how to search by parameter number using the 20-HIM-A6 module.

Parameter Search and Configuration by Parameter Number

To perform a parameter number search and modification, perform the following steps.

Parameter Search and Configuration by Parameter Number

1. Ensure that the initial SMC-50 controller Power Up screen appears on the HIM.



2. Using the PAR# soft key, type the desired parameter number to display, press the ENTER soft key, then press the EDIT soft key. The following screen appears.

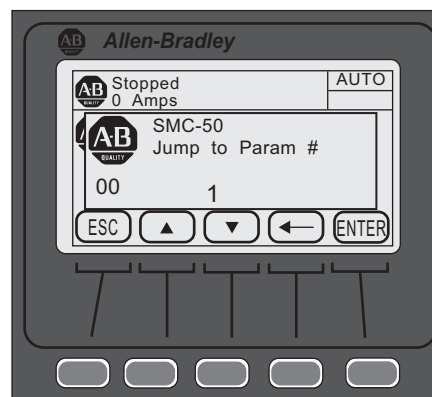

TIP To access the next/previous PAR# from the one currently displayed, use the UP/DOWN arrow soft keys to display the desired parameter for modification.

3. Press ENTER to load the changed value into memory.

TIP For a complete SMC-50 controller linear list, see [Table 74](#) through [Table 79](#) beginning on [page 184](#)

For additional details on these procedures, see the 20-HIM-A6 or 20-HIM-C6S user manual, publication [20HIM-UM001](#).

Parameter Search and Configuration by File-Group Structure

Parameter Structure

The parameters of the SMC-50 controller are structured into five parameter File-Groups:

1. Monitoring
2. Setup
3. Motor Protection
4. Communications
5. Utility

The parameters associated with each of these five File-Groups are shown in [Table 69](#) through [Table 73](#) beginning on [page 181](#) of this chapter.

Parameter Search and Configuration by File-Group (SMC-50 Controller Category Search)

1. From the HIM Power-Up screen, press the FOLDERS single-function key.
2. Press the LEFT or RIGHT arrow key until the screen displays DEV PARAM. Ensure Port 00 SMC-50 controller is selected from the PORTS screen.

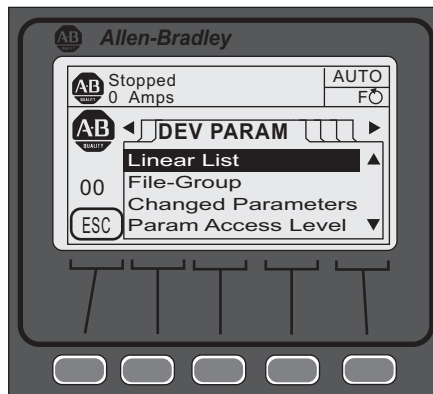

3. Using the DOWN arrow key, scroll to the File-Group selection, then press ENTER (#5 keypad). The screen displays Port 00 Param File-Group at the top of the screen.

4. Using the DOWN arrow key, scroll to the Set Up selection, then press ENTER. The screen displays the setup categories (for example, Basic, Starting).

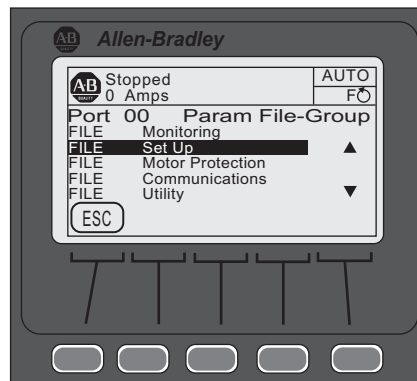

5. With Basic highlighted, press ENTER (number 5 on the keypad).
6. Scroll to the desired parameter (for example, Line Voltage) to modify it, then press ENTER (number 5 on the keypad).
7. With the parameter displayed, press the EDIT soft key.
8. Enter the desired value, then press the ENTER soft key to save the value.
9. Press the ESC key to return to the Basic category.
10. To modify another parameter in the Basic category, follow steps 5 through 7. To return to a higher level category, press the BACK arrow key.

TIP Using the DEV PARAM folder screen and the File-Group selection, SMC-50 controller parameters can be selected and configured by functional category. See the [Parameter File-Group Structure on page 181](#).

Parameter Configuration - Overview Using the Setup File Group

Table 58 shows the parameter sets available within the Basic Setup group.

Table 58 - Setup File Group

Setup File Group Parameters									
Basic (BA)		Starting (BA)	Stopping (BA)	Slow Speed	Dual Ramp (BA)	Advanced	I/O (BA)	Advanced Tuning	
Motor Config	Input 2	Starting Mode	Stop Mode	Slow Speed (BA)	Starting Mode 2	Pump Pedestal (A)	Input 1	Force Tuning (A)	Phase Shift 0% (A)
Line Voltage	Aux 1 Config	Ramp Time	Stop Time		Ramp Time 2	Load Type (A)	Input 2	Starter R	Phase Shift 10% (A)
Starting Mode	Aux 2 Config	Cur Limit Level	Braking Current	Slow Brake Cur (BA)	Cur Limit Level 2	High Eff Brake (A)	Aux 1 Config	Total R	Phase Shift 20% (A)
	Overload Class	Initial Torque	Backspin Timer		Initial Torque 2	UTS Level (A)	Aux 1 Invert	Coupling Factor	Phase Shift 30% (A)
Ramp Time		Starting Torque		SS Ref Gain (A)	Starting Torque 2	Stall Position (A)	Aux 1 On Delay	Inductance	Phase Shift 40% (A)
Initial Torque	Service Factor	Max Torque			Max Torque 2	Stall Level (A)	Aux 1 Off Delay	Speed PGain (A)	Phase Shift 50% (A)
Max Torque		Kickstart Time			SS Trans Gain (A)	Kickstart Time 2	V Shut Off Level (A)	Aux 2 Config	Transient Gain (A)
Cur Limit Level	Motor FLC	Kickstart Level			Kickstart Level 2	I Shut Off Level (A)	Aux 2 Invert	Transient Zero (A)	Phase Shift 70% (A)
Stop Mode	Starting Torque	Heating Time				Notch Maximum (A)	Aux 2 On Delay	Transient Mag (A)	Phase Shift 80% (A)
		Heating Level				Timed Start (A)	Aux 2 Off Delay		Phase Shift 90% (A)
Stop Time	Max Torque	Start Delay				Bypass Delay (A)	Aux Control	Phase Shift 100% (A)	
Input 1	Rated Torque					Energy Saver (BA)			
	Rated Speed					Demand Period (BA)			
						Num of Periods (BA)			

TIP For a complete parameter set listing within each parameter File—Group, see [Parameter File-Group Structure on page 181](#).

The Basic parameter set in the setup group is limited, yet powerful. It lets you quickly start the system with minimal adjustments and provides quick access to parameters that are required for standard motor connection and overload protection. If you are using advanced controller features (for example, Dual Ramp, Braking), however, you must also use the parameter set that is associated with those features. The Setup group is used throughout this section as a baseline for system configuration.

IMPORTANT Parameter values that are modified while the motor is operating are not valid until the next time the operation for that parameter occurs.



ATTENTION: For Overload Protection, it is critical that you enter the data into the SMC-50 controller as it appears on the motor nameplate.

Figure 97 shows the initial FILE Setup screens using the HIM.

Figure 97 - Initial FILE Setup Screens

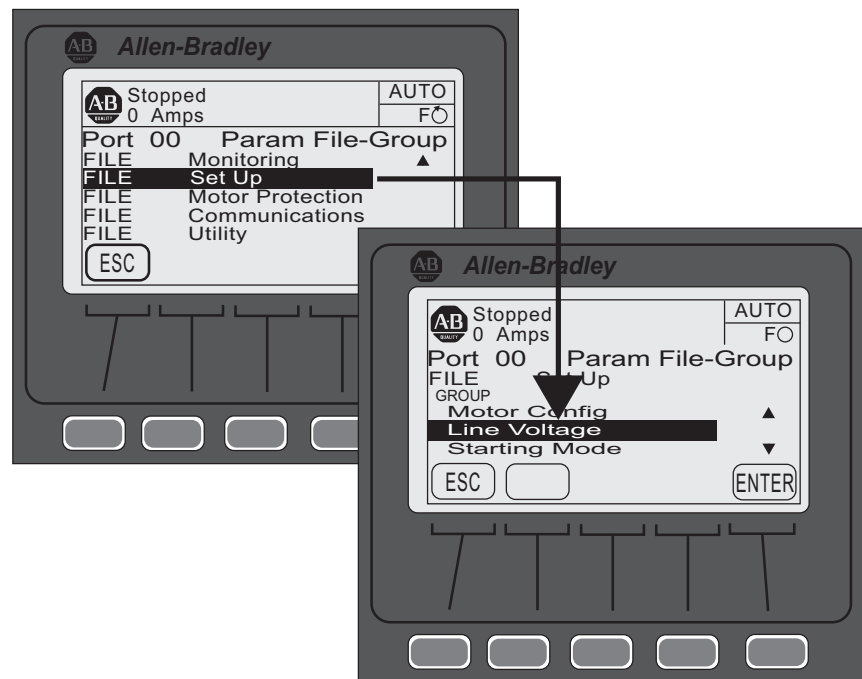

Soft Start and Stop

To program a soft start with simple stop mode operation, you can use the parameters listed in [Table 59](#). You can access the Basic parameter set with the HIM from the Port <00> DEV PARAM folder under the File-Group, File: Setup, Group: Basic Selection sequence.

Table 59 - Soft Start Parameter Group

Parameter Name	Description	Options	Default Value
Motor Configuration	Setting for the motor configuration Line Connected Wye or Inside-the-Delta. ⁽¹⁾	Line, Delta, Auto Detect	Auto Detect
Line Voltage	Select the value of line voltage being used in the system. You must enter the correct line voltage value for the voltage protection functions to work properly.	0...700V	480V
Starting Mode	This mode must be programmed for Soft Start.	Soft Start ⁽⁵⁾⁽⁶⁾	Soft Start ⁽⁵⁾⁽⁶⁾
Ramp Time	Programs the time period that the SMC-50 controller will ramp the output voltage up to full voltage and to full speed from the Initial Torque level.	0...1000 s	10 s
Initial Torque	The initial reduced output voltage (torque) level for the voltage ramp to the motor is established and adjusted with this parameter—the torque level at which the ramp begins.	0...90% LRT	70% LRT
Current Limit Level	Limits the current supplied to the motor throughout the Soft Start cycle. ⁽²⁾	50...600% FLC	350% FLC
Stop Mode	Programs the desired Stop Mode. ⁽³⁾	Coast, Soft Stop, Linear Speed, Pump Stop, SMB ⁽⁷⁾ , Ext Brake ⁽⁸⁾	Coast
Stop Time	Programs the amount of time desired to ramp from full to zero voltage for Soft, Linear, and Pump Stop mode. The actual ramp stop time will depend on the stopping mode selected and load inertia.	0...999 s	0 s
Input 1	Programs the desired operation of the Control Module to a change in status of Input #1 wired to control terminal #11 (24V DC).	Disable, Start, Coast, Stop Option, Start/Coast, OL Select, Fault, Fault NC, Clear Fault, Emerg Run, Motor Heater	Start/Coast
Input 2	Programs the desired operation of the Control Module to a change in status of Input #2 wired to control terminal #10 (24V DC).		Disable

Parameter Name	Description	Options	Default Value
Aux 1 Config	Aux 1 Config Programs the control function of the Auxiliary Output Contact #1, wired across control terminal #4 and #5. ⁽⁴⁾	Normal, UTS, Fault, Alarm, Ext Bypass, Ext Brake, Aux Control ⁽⁵⁾ , Network 1, Network 2, Network 3, Network 4, Fan Control	Normal
Aux 2 Config	Programs the control function of the Auxiliary Output Contact #2, wired across control terminal #6 and #7. ⁽⁴⁾		
Overload Class	Required for motor protection. Lets you select the time-to-trip for the built-in Motor Overload. This selection is based on the type of motor being used and the application it is being applied to.	5...30	10
Service Factor	Required for motor protection. This value is taken directly from the nameplate and used by the controller to determine the ultimate Overload Trip Current.	0.01...1.99	1.15
Motor FLC	Required for motor protection. This programmed value is taken directly from the motor nameplate.	1.0...2200.0 A	1.0 A
Starting Torque	NOT used for a Soft Start.	0...300% RMT	100% RMT
Max Torque	NOT used for a Soft Start.	0...300% RMT	250% RMT
Rated Torque	NOT used for a Soft Start.	0...10000 N·m	10 N·m
Rated Speed	NOT used for a Soft Start.	750, 900, 1500, 1800, 3500, 3600 rpm	1800 rpm

- (1) In the AUTO Detect [default] selection, the controller automatically checks the motor configuration.
- (2) Enter a value to limit the current but not low enough to inhibit the start cycle.
- (3) The stopping mode does not need to match the starting mode (for example, a Soft Start can have a stop mode programmed for [Coast], Linear Stop, or SMB—there is no Current Limit Stop or Torque Stop mode).
- (4) Relay Operational Options (for example, ON and OFF delay, etc.) are provided in the File: Setup, Group: I/O selection sequence. See [Table 58](#).
- (5) Kickstart is available when using Soft Start. A Kickstart Level and Time must be configured if this mode is used. Access these parameters via the Starting Setup Group. The Starting Setup Group can be accessed with the HIM from the Port <00> DEV PARAM folder under the File-Group, File: Setup, Group: Starting selection sequence (see [Table 58](#)). Setting either parameter to zero disables Kickstart.
- (6) You can also program a start delay time to delay starting for a period of time after the initiation of the START command. The Start Delay parameter can be accessed from the Group Starting selection as noted.
- (7) In addition to Stop Mode for SMB, you must configure a Braking Current value from the Group Stopping selection (see [Table 58](#)).
- (8) To use Ext. Braking, one of the Auxiliary Outputs must be programmed to Ext Brake. When programmed for Ext Brake, the function of this Auxiliary is to energize the external brake device to stop the motor. The relay stays ON from the beginning of the STOP command until the STOP time parameter has timed out.
- (9) Any auxiliary output configured for Aux Control using the AuxX Config parameter is under control of its associated bit from the Aux Control, Parameter 180. See Parameter 180 information for bit assignments.

NOTE: This function enables forcing an output, ON or OFF.



ATTENTION: For Overload Protection, it is critical that you enter the data into the SMC-50 controller as it appears on the motor nameplate.

Current Limit Start with Simple Stop Mode

Use the parameters in [Table 60](#) to program a Current Limit Start with simple Stop Mode operation. You can access the Basic parameter set with the HIM (see [page 33](#)).

Table 60 - Current Limit Start with Simple Stop Mode Parameters

Parameter Name	Description	Options	Default Value
Motor Config	Setting for the motor configuration Line Connected Wye or Inside-the-Delta. ⁽¹⁾	Line, Delta, Auto Detect	Auto Detect
Line Voltage	Select the value of line voltage being used in the system. The correct line voltage value must be entered for the voltage protection functions to work properly.	0...700V	480V
Starting Mode	This mode must be programmed for Current Limit.	Current Limit ⁽⁵⁾⁽⁶⁾	Current Limit ⁽⁵⁾⁽⁶⁾
Ramp Time	Programs the time period that the SMC-50 controller will HOLD the fixed reduced voltage/current before switching to full voltage.	0...1000 [10] seconds	10 s
Initial Torque	NOT used for a Current Limit Start.	0...90% LRT	70% LRT
Current Limit Level	Current Limit Level Limits the current supplied to the motor throughout the Start cycle. ⁽²⁾	50...600% FLC	350% FLC
Stop Mode	Programs the desired Stop Mode. ⁽³⁾	Coast, Soft Stop, Linear Speed, Pump Stop, SMB ⁽⁷⁾ , Ext Brake ⁽⁸⁾	Coast

Parameter Name	Description	Options	Default Value
Stop Time	Programs the amount of time desired to ramp from full to zero voltage for Soft, Linear, and Pump Stop mode. The actual ramp stop time will depend on the stopping mode selected and load inertia.	0 . . . 999 seconds	0 s
Input 1	Programs the desired operation of the Control Module to a change in status of Input #1 wired to control terminal #11 (24V DC).	Disable, Start, Coast, Stop Option, Start/Coast, Start/Stop, Slow Speed, Dual Ramp, OL Select, Fault, Fault NC, Clear Fault, Emerg Run, Motor Heater ⁽⁵⁾	Start/Coast
Input 2	Programs the desired operation of the Control Module to a change in status of Input #2 wired to control terminal #10 (24V DC).		Disable
Aux 1 Config	Programs the control function of the Auxiliary Output Contact #1, wired across control terminal #4 and #5. ⁽⁴⁾	Normal, UTS, Fault, Alarm, Ext Bypass, Ext Brake, Aux Control ⁽⁹⁾ , Network 1, Network 2, Network 3, Network 4, Fan Control	Normal
Aux 2 Config	Programs the control function of the Auxiliary Output Contact #2, wired across control terminal #6 and #7.		
Overload Class	Required for motor protection. Lets you select the time-to-trip for the built-in Motor Overload. This selection is based on the type of motor being used and the application it is being applied to.	5 . . . 30	10
Service Factor	Required for motor protection. This programmed value is taken directly from the nameplate and used by the controller to determine the ultimate Overload Trip Current.	0.01...1.99	1.15
Motor FLC	Required for motor protection. This programmed value is taken directly from the motor nameplate.	1.0...2200.0 A	1.0 A
Starting Torque	NOT used for a Current Limit Start.	0...300% RMT	100% RMT
Max Torque	NOT used for a Current Limit Start.	0...300% RMT	250% RMT
Rated Torque	NOT used for a Current Limit Start.	0...10000 N-m	10 N-m
Rated Speed	NOT used for a Current Limit Start.	750, 900, 1500, 1800, 3500, 3600 rpm	1800 rpm

- (1) In the AUTO Detect [default] selection, the controller automatically checks the motor configuration.
- (2) Enter a value to limit the current but not low enough to inhibit the start cycle.
- (3) The stopping mode does not need to match the starting mode (for example, a Soft Start can have a stop mode programmed for [Coast], Linear Stop, or SMB—there is no Current Limit Stop or Torque Stop mode).
- (4) Relay Operational Options (for example, ON and OFF delay, etc.) are provided in the File: Setup, Group: I/O selection sequence. See [Table 58](#).
- (5) Kickstart is available when using Soft Start. A Kickstart Level and Time must be configured if this mode is used. Access these parameters via the Starting Setup Group. The Starting Setup Group can be accessed with the HIM from the Port <00> DEV PARAM folder under the File-Group, File: Setup, Group: Starting selection sequence (see [Table 58](#)). Setting either parameter to zero disables Kickstart.
- (6) You can also program a start delay time to delay starting for a period of time after the initiation of the START command. The Start Delay parameter can be accessed from the Group Starting selection as noted.
- (7) In addition to Stop Mode for SMB, you must configure a Braking Current value from the Group Stopping selection (see [Table 58](#)).
- (8) To use Ext. Braking, one of the Auxiliary Outputs must be programmed to Ext Brake. When programmed for Ext Brake, the function of this Auxiliary is to energize the external brake device to stop the motor. The relay stays ON from the beginning of the STOP command until the STOP time parameter has timed out.
- (9) Any auxiliary output configured for Aux Control using the AuxX Config parameter is under control of its associated bit from the Aux Control, Parameter 180. See Parameter 180 information for bit assignments.

NOTE: This function enables forcing an output, ON or OFF.



ATTENTION: For Overload Protection, it is critical that you enter the data into the SMC-50 controller as it appears on the motor nameplate.

Linear Acceleration (Linear Speed) Start with Stop

Use the parameters in [Table 61](#) to program a Linear Acceleration Start and Simple Stop Mode operation. You can access the Basic parameter set with the HIM (see [Table 58](#)).

Table 61 - Linear Acceleration (Speed Sense) Start with Stop Parameters

Parameter Name	Description	Options	Default Value
Motor Config	Setting for the motor configuration Line Connected Wye or Inside-the-Delta. ⁽¹⁾	Line, Delta, Auto Detect	Auto Detect
Line Voltage	Select the value of line voltage being used in the system. The correct line voltage value must be entered for the voltage protection functions to work properly.	0 . . . 700V	480V
Starting Mode	This mode must be programmed for Linear Speed.	Linear Speed ⁽⁵⁾⁽⁶⁾	Linear Speed ⁽⁵⁾⁽⁶⁾

Parameter Name	Description	Options	Default Value
Ramp Time	Programs the time period that the SMC-50 controller will ramp the output voltage up to full voltage and to full speed from Stop. With the Linear Speed Starting mode, the time to ramp to full speed closes to this value depending on load characteristics.	0...1000 s	10 seconds
Initial Torque	The initial reduced output (torque) level for the voltage ramp to the motor is established and adjusted to this parameter. Torque level at which the ramp begins.	0...90% LRT	70% LRT
Current Limit Level	Limits the current supplied to the motor throughout the Linear Start and Stop cycle. ⁽²⁾	50...600% FLC	350% FLC
Stop Mode	Programs the desired Stop Mode. ⁽³⁾	Coast, Soft Stop, Linear Speed, Pump Stop, SMB ⁽⁷⁾ , Ext Brake ⁽⁸⁾	Coast
Stop Time	Programs the amount of time desired to ramp from full to zero voltage for Soft, Linear, and Pump Stop mode. Actual ramp stop time depends on the stopping mode selected and load inertia.	0...999 s	0 s
Input 1	Programs the desired operation of the Control Module to a change in status of Input #1 wired to control terminal #11 (24V DC).	Disable, Start, Coast, Stop Option, Start/Coast, Start/Stop, Slow Speed, Dual Ramp, OL Select, Fault, Fault NC, Clear Fault, Emerg Run, Motor Heater	Start/Coast
Input 2	Programs the desired operation of the Control Module to a change in status of Input #2 wired to control terminal #10 (24V DC).		Disable
Aux 1 Config	Programs the control function of the Auxiliary Output Contact #1, wired across control terminal #4 and #5. ⁽⁴⁾	Normal, UTS, Fault, Alarm, Ext Bypass, Ext Brake, Aux Control ⁽⁵⁾ , Network 1, Network 2, Network 3, Network 4, Fan Control	Normal
Aux 2 Config	Programs the control function of the Auxiliary Output Contact #2, wired across control terminal #6 and #7. ⁽⁴⁾		
Overload Class	Required for motor protection. Lets you select the time-to-trip for the built-in Motor Overload. This selection is based on the type of motor being used and the application.	5...30	10
Service Factor	Required for motor protection. This programmed value is taken directly from the nameplate and used by the controller to determine the ultimate Overload Trip Current.	0.01...1.99	1.15
Motor FLC	Required for motor protection. This programmed value is taken directly from the motor nameplate.	1.0...2200.0 A	1.0 Amps
Starting Torque	NOT used for a Linear Speed Start.	0...300% RMT	100 RMT
Max Torque	NOT used for a Linear Speed Start.	0...300% RMT	250% RMT
Rated Torque	NOT used for a Linear Speed Start.	0...10000 N-m	10 N-m
Rated Speed	NOT used for a Linear Speed Start.	750, 900, 1500, 1800, 3500, 3600 rpm	1800 rpm

- (1) In the AUTO Detect [default] selection, the controller automatically checks the motor configuration.
- (2) Enter a value to limit the current but not low enough to inhibit the start cycle.
- (3) The stopping mode does not need to match the starting mode (for example, a Soft Start can have a stop mode programmed for [Coast], Linear Stop, or SMB—there is no Current Limit Stop or Torque Stop mode).
- (4) Relay Operational Options (for example, ON and OFF delay, etc.) are provided in the File: Setup, Group: I/O selection sequence. See [Table 58](#).
- (5) Kickstart is available when using Soft Start. A Kickstart Level and Time must be configured if this mode is used. Access these parameters via the Starting Setup Group. The Starting Setup Group can be accessed with the HIM from the Port <00> DEV PARAM folder under the File-Group, File: Setup, Group: Starting selection sequence (see [Table 58](#)). Setting either parameter to zero disables Kickstart.
- (6) You can also program a start delay time to delay starting for a period of time after the initiation of the START command. The Start Delay parameter can be accessed from the Group Starting selection as noted.
- (7) In addition to Stop Mode for SMB, you must configure a Braking Current value from the Group Stopping selection (see [Table 58](#)).
- (8) To use Ext. Braking, one of the Auxiliary Outputs must be programmed to Ext Brake. When programmed for Ext Brake, the function of this Auxiliary is to energize the external brake device to stop the motor. The relay stays ON from the beginning of the STOP command until the STOP time parameter has timed out.
- (9) Any auxiliary output configured for Aux Control using the AuxX Config parameter is under control of its associated bit from the Aux Control, Parameter 180. See Parameter 180 information for bit assignments.
NOTE: This function enables forcing an output, ON or OFF.



ATTENTION: For Overload Protection, it is critical that you enter the data into the SMC-50 controller as it appears on the motor nameplate.

Torque Start with Stop

Use the parameters in [Table 62](#) to program a Torque Start with simple Stop operation. You can access the basic parameter set with the HIM (see [Table 58 on page 168](#)).

Table 62 - torque Start with Stop Parameters

Parameter Name	Description	Options	Default Value
Motor Config	Setting for the motor configuration Line Connected Wye or Inside-the-Delta. ⁽¹⁾	Line, Delta, Auto Detect	Auto Detect
Line Voltage	Select the value of line voltage being used in the system. The correct line voltage value must be entered for the voltage protection functions to work properly.	0...700V	480V
Starting Mode	This mode must be programmed for Torque Ramp.	Torque Ramp ⁽⁵⁾⁽⁶⁾⁽⁷⁾	Torque Ramp ⁽⁵⁾⁽⁶⁾⁽⁷⁾
Ramp Time	Programs the time period that the SMC-50 controller will ramp the output voltage from the Starting Torque Value to the Programmed Max Torque Value.	0...1000 s	10 s
Initial Torque	NOT used for a Torque Ramp Start.	0...90% LRT	70% LRT
Current Limit Level	Limits the current supplied to the motor throughout the Torque Ramp Start cycle. ⁽²⁾	50...600% FLC	350% FLC
Stop Mode	Programs the desired Stop Mode. ⁽³⁾	Coast, Soft Stop, Linear Speed, Pump Stop, SMB ⁽⁸⁾ , Ext Brake ⁽⁹⁾	Coast
Stop Time	Stop Time Programs the amount of time desired to ramp from full to zero voltage for Soft, Linear, and Pump Stop mode. The actual ramp stop time will depend on the stopping mode selected and load inertia.	0...999 seconds	0...999 s
Input 1	Input 1 Programs the desired operation of the Control Module to a change in status of Input #1 wired to control terminal #11 (24V DC). [Default: Start/Coast]	Disable, Start, Coast, Stop Option, Start/Coast, Start/Stop, Slow Speed, Dual Ramp, OL Select, Fault, Fault NC, Clear Fault, Emerg Run, Motor Heater	Start/Coast
Input 2	Input 2 Programs the desired operation of the Control Module to a change in status of Input #2 wired to control terminal #10 (24V DC). [Default: Disable]		Disable
Aux 1 Config	Programs control function of the Auxiliary Output Contact #1, wired across control terminal #4 and #5. ⁽⁴⁾	Normal, UTS, Fault, Alarm, Ext Bypass, Ext Brake, Aux Control ⁽¹⁰⁾ , Network 1, Network 2, Network 3, Network 4, Fan Control	Normal
Aux 2 Config	Programs control function of the Auxiliary Output Contact #2, wired across control terminal #6 and #7. ⁽⁴⁾		
Overload Class	Required for motor protection. Lets you select the time-to-trip for the built-in Motor Overload. This selection is based on the type of motor being used and the application.	5...30 10	10
Service Factor	Required for motor protection. This programmed value is taken directly from the nameplate and used by the controller to determine the ultimate Overload Trip Current.	0.01...1.99	1.15
Motor FLC	Required for motor protection. This programmed value is taken directly from the motor nameplate.	1...2200 Amps	1.0 A
Starting Torque	Programmed initial or starting point for a Torque Ramp Start.	0...300% RMT	100% RMT
Max Torque	Programmed end point for a Torque Ramp Start.	0...300% RMT	250% RMT
Rated Torque	The actual rated torque of the motor being used in a Torque Ramp Start.	0...10000 N-m	10 N-m
Rated Speed	The actual rated speed of the motor used in the Torque Ramp Start.	750, 900, 1500, 1800, 3500, 3600 rpm	1800 rpm

- (1) In the AUTO Detect [default] selection, the controller automatically checks the motor configuration.
- (2) Enter a value to limit the current but not low enough to inhibit the start cycle.
- (3) The stopping mode does not need to match the starting mode (for example, a Soft Start can have a stop mode programmed for Coast, Linear Stop, or SMB—there is no Current Limit Stop or Torque Stop mode).
- (4) Relay Operational Options (for example, ON and OFF delay, etc.) are provided in the File: Setup, Group: I/O selection sequence. See [Table 58](#).
- (5) Torque Ramp Starting mode requires you to perform a Motor Tuning Cycle. The SMC-50 controller does this automatically the first time the motor is run. You can also force this manually by setting the Force Tuning, Parameter 194, to TRUE (=1), which is accessed from the File Setup, Group Adv. Tuning or by pressing and holding the SMC-50 controller's Reset button for 10 seconds with the motor stopped.
- (6) You can also program a start delay time to delay starting for a period of time after the initiation of the START command. You can access the Start Delay parameter from the Group Starting selection. See [Table 58](#).
- (7) Kickstart is available when using Torque Start. You must configure a Kickstart Level and Time if you use this mode is. Access these parameters via the Starting Setup Group. You can access the Starting Setup Group with the HIM from the Port <00> DEV PARAM folder under the File-Group, File: Setup, Group: Starting selection sequence. See [Table 58](#). Setting either parameter to zero disables Kickstart
- (8) In addition to Stop Mode for SMB, you must configure a Braking Current value from the Group Stopping selection ([Table 58](#)).
- (9) To use Ext. Braking, you must program one of the Auxiliary Outputs to Ext Brake. When programmed for Ext Brake, this Auxiliary is to energizes the external brake device to stop the motor. The relay stays ON from the beginning of the STOP command until the STOP time parameter has timed out.
- (10) Any auxiliary output configured for Aux Control using the AuxX Config parameter is under control of its associated bit from the Aux Control, Parameter 180. See Parameter 180 information for bit assignments. NOTE: This function enables forcing an output, ON or OFF.



ATTENTION: For Overload Protection, it is critical that you enter the data into the SMC-50 controller as it appears on the motor nameplate.

Pump Start with Stop

Use the parameters in [Table 63](#) to program a Pump Start with simple Stop operation. You can access the basic parameter set with the HIM (see [Table 58 on page 168](#))

Table 63 - Pump Start with Stop Parameters

Parameter Name	Description	Options	Default Value
Motor Config	Setting for the motor configuration Line Connected Wye or Inside-the-Delta. ⁽¹⁾	Line, Delta, Auto Detect	Auto Detect
Line Voltage	Select the value of line voltage being used in the system. The correct line voltage value must be entered for the voltage protection functions to work properly.	0...700V	480V
Starting Mode	This mode must be programmed for Pump Start.	Pump Start ⁽⁵⁾⁽⁶⁾	Pump Start ⁽⁵⁾⁽⁶⁾
Ramp Time	Programs the time period that the SMC-50 controller will ramp the output voltage to full voltage and motor speed from the programmed Initial Torque value.	0...1000 s	10 s
Initial Torque	The initial reduced output voltage (torque) level for the voltage ramp to the motor is established and adjusted with this parameter. The torque level at which the ramp begins.	0...90% LRT	70% LRT
Current Limit Level	Limits the current supplied to the motor throughout the Torque Ramp Start cycle. ⁽²⁾	50...600% FLC	350% FLC
Stop Mode	Programs the desired Stop Mode. ⁽³⁾	Coast, Soft Stop, Linear Speed, Pump Stop, SMB ⁽⁷⁾ , Ext Brake ⁽⁸⁾	Coast
Stop Time	Programs the amount of time desired to ramp from full to zero voltage for Soft, Linear, and Pump Stop mode. Actual ramp stop time depends on the stop mode selected and load inertia.	0...999 s	0 s
Input 1	Programs the desired operation of the Control Module to a change in status of Input #1 wired to control terminal #11 (24V DC).	Disable, Start, Coast, Stop Option, Start/Coast, Start/Stop, Slow Speed, Dual Ramp, OL Select, Fault, Fault NC, Clear Fault, Emerg Run, Motor Heater	Start/Coast
Input 2	Programs the desired operation of the Control Module to a change in status of Input #2 wired to control terminal #10 (24V DC).		Disable
Aux 1 Config	Programs the control function of the Auxiliary Output Contact #1, wired across control terminal #4 and #5. ⁽⁴⁾	Normal, UTS, Fault, Alarm, Ext Bypass, Ext Brake, Aux Control ⁽⁹⁾ , Network 1, Network 2, Network 3, Network 4, Fan Control	Normal
Aux 2 Config	Programs the control function of the Auxiliary Output Contact #2, wired across control terminal #6 and #7. ⁽⁴⁾		
Overload Class	Required for motor protection. Lets you select the time-to-trip for the built-in Motor Overload. This selection is based on the type of motor being used and the application.	5...30	10
Service Factor	Required for motor protection. This programmed value is taken directly from the nameplate and used by the controller to determine the ultimate Overload Trip Current.	0.01...1.99	1.15
Motor FLC	Required for motor protection. This programmed value is taken directly from the motor nameplate.	1...2200 A	1 A
Starting Torque	NOT used for Pump Start.	0...300% RMT	100% RMT
Max Torque	NOT used for Pump Start.	0...300% RMT	250% RMT
Rated Torque	NOT used for Pump Start.	0...10000 N-m	10 N-m
Rated Speed	NOT used for Pump Start.	750, 900, 1500, 1800, 3500, 3600 rpm	1800 rpm

- (1) In the AUTO Detect [default] selection, the controller automatically checks the motor configuration.
- (2) Enter a value to limit the current but not low enough to inhibit the start cycle.
- (3) The stop mode does not need to match the start mode (example: a Soft Start can have a stop mode programmed for Coast, Linear Stop, or SMB—there is no Current Limit Stop or Torque Stop mode).
- (4) Relay Operational Options (for example, ON and OFF delay, etc.) are provided in the File: Setup, Group: I/O selection sequence. See [Table 58](#).
- (5) For best results with a Pump Start, it is recommended that the tuning cycle be run. The SMC-50 controller automatically performs the tuning cycle the first time the motor is run. You can also force this manually by setting the Force Tuning parameter to TRUE (=1), which is accessed from the File Setup, Group Adv. Tuning or by pressing and holding the SMC-50 controller's Reset button for 10 seconds with the motor stopped.
- (6) You can program a start delay time to delay starting for a period after the initiation of the START command. You can access the Start Delay parameter from the Group Starting selection. See [Table 58](#).
- (7) In addition to Stop Mode for SMB, you must configure a Braking Current value from the Group Stopping selection ([Table 58](#)).
- (8) To use Ext. Braking, you must program one of the Auxiliary Outputs to Ext Brake. When programmed for Ext Brake, this Auxiliary is to energizes the external brake device to stop the motor. The relay stays ON from the beginning of the STOP command until the STOP time parameter has timed out.
- (9) Any auxiliary output configured for Aux Control using the AuxX Config parameter is under control of its associated bit from the Aux Control, Parameter 180. See Parameter 180 information for bit assignments. NOTE: This function enables forcing an output, ON or OFF.



ATTENTION: For Overload Protection, it is critical that you enter the data into the SMC-50 controller as it appears on the motor nameplate.

Full Voltage Start with Stop

The SMC-50 controller may be programmed to provide a full voltage start (output voltage to the motor reaches full voltage within five line power cycles).

To provide a Full Voltage Start to the motor, the only start parameter that requires adjustment is the Starting Mode. The Basic parameter set should be used to program Full Voltage Start to ensure configuration of other motor configuration and basic protection parameters. Use the parameters in [Table 64](#) to program a Full Voltage Start and Simple or Stop Mode operation. You can access the basic parameter set with the HIM (see [Table 58 on page 168](#)).

Table 64 - Full Voltage Start with Stop Parameters

Parameter Name	Description	Options	Default Value
Motor Config	Setting for the motor configuration Line Connected Wye or Inside-the-Delta. ⁽¹⁾	Line, Delta, Auto Detect	Auto Detect
Line Voltage	Select the value of line voltage being used in the system. The correct line voltage value must be entered for the voltage protection functions to work properly.	0...700V	480V
Starting Mode	This mode must be programmed for Full Voltage Start.	Full Voltage ⁽⁴⁾	Full Voltage ⁽⁴⁾
Ramp Time	Programs the time period that the SMC-50 controller will ramp the output voltage to full voltage and motor speed from the programmed Initial Torque value.	0...1000 s	10 s
Initial Torque	NOT used for Full Voltage Start.	0...90% LRT	70% LRT
Current Limit	NOT used for Full Voltage Start.	50...600% FLC	350% FLC
Stop Mode	Programs the desired Stop Mode. ⁽²⁾	Coast, Soft Stop, Linear Speed, Pump Stop, SMB ⁽⁵⁾ , Ext Brake ⁽⁶⁾	Coast
Stop Time	Programs the amount of time desired to ramp from full to zero voltage for Soft, Linear, and Pump Stop mode. Actual ramp stop time depends on the stop mode selected and load inertia.	0...999 s	0 s
Input 1	Programs the desired operation of the Control Module to a change in status of Input #1 wired to control terminal #11 (24V DC).	Disable, Start, Coast, Stop Option, Start/Coast, Start/Stop, Slow Speed, Dual Ramp, OL Select, Fault, Fault NC, Clear Fault, Emerg Run, Motor Heater	Start/Coast
Input 2	Programs the desired operation of the Control Module to a change in status of Input #2 wired to control terminal #10 (24V DC).		Disable
Aux 1 Config	Programs the control function of the Auxiliary Output Contact #1, wired across control terminal #4 and #5. ⁽³⁾	Normal, UTS, Fault, Alarm, Ext Bypass, Ext Brake, Aux Control ⁽⁷⁾ , Network 1, Network 2, Network 3, Network 4, Fan Control	Normal
Aux 2 Config	Programs the control function of the Auxiliary Output Contact #2, wired across control terminal #6 and #7. ⁽⁴⁾		
Overload Class	Required for motor protection. Lets you select the time-to-trip for the built-in Motor Overload. This selection is based on the type of motor being used and the application.	5...30	10
Service Factor	Required for motor protection. This programmed value is taken directly from the nameplate and used by the controller to determine the ultimate Overload Trip Current.	0.01...1.99	1.15
Motor FLC	Required for motor protection. This programmed value is taken directly from the motor nameplate.	1...2200 A	1 A
Starting Torque	Starting Torque NOT used for Full Voltage Start.	0...300% RMT	100% RMT

Parameter Name	Description	Options	Default Value
Max Torque	NOT used for Full Voltage Start.	0...300% RMT	250% RMT
Rated Torque	NOT used for Full Voltage Start.	0...10000 N·m	10 N·m
Rated Speed	NOT used for Full Voltage Start.	750, 900, 1500, 1800, 3500, 3600 rpm	1800 rpm

- (1) In the AUTO Detect [default] selection, the controller automatically checks the motor configuration.
- (2) The stopping mode does not need to match the starting mode (for example, a Soft Start can have a stop mode programmed for Coast, Linear Stop, or SMB—there is no Current Limit Stop or Torque Stop mode).
- (3) Relay Operational Options (for example, ON and OFF delay, etc.) are provided in the File: Setup, Group: I/O selection sequence. See [Table 58](#).
- (4) You can also program a start delay time to delay starting for a period of time after the initiation of the START command. You can access the Start Delay parameter from the Group Starting selection. See [Table 58](#).
- (5) In addition to Stop Mode for SMB, you must configure a Braking Current value from the Group Stopping selection ([Table 58](#)).
- (6) To use Ext. Braking, you must program one of the Auxiliary Outputs to Ext Brake. When programmed for Ext Brake, this Auxiliary is to energizes the external brake device to stop the motor. The relay stays ON from the beginning of the STOP command until the STOP time parameter has timed out.
- (7) Any auxiliary output configured for Aux Control using the AuxX Config parameter is under control of its associated bit from the Aux Control, Parameter 180. See Parameter 180 information for bit assignments. NOTE: This function enables forcing an output, ON or OFF.



ATTENTION: For Overload Protection, it is critical that you enter the data into the SMC-50 controller as it appears on the motor nameplate.

Dual Ramp Start with Stop

The SMC-50 controller lets you select between two start profiles. Configure Start Profile 1 using the Basic parameter set as explained in the previous sections. You can access the basic parameter set with the HIM (see [Table 58 on page 168](#)).

TIP The Stop mode selected in the Basic parameter set will apply to both start profiles.

The Basic parameter set provides the method to select between the operation of Start Profile 1 and Start Profile 2 by configuration of Input 1 or Input 2 to the Dual Ramp. If the input configured for Dual Ramp is open (low), Start Profile 1 is selected. If the input is closed (high), Profile 2 is selected.

Set up Start Profile 2 by using the Dual Ramp parameter set. You can use the HIM to access Dual Ramp from the <Port 00> DEV PARAM folder (see [Table 58 on page 168](#)). Use the parameters in [Table 65](#) to program a Dual Ramp adjustment.

Table 65 - Dual Ramp Start with Stop Parameters

Parameter Name	Description	Options	Default Value
Starting Mode 2	Select the desired starting mode for Profile 2	Soft Start, Full Voltage, Linear Speed, Torque Start, Current Limit, Pump Start. ^{(3) (4)}	—
Ramp Time 2	Programs the Profile 2 time period that the SMC-50 controller will ramp the output voltage to full voltage and motor speed from the programmed Initial Torque value.	0...1000 s	10 s
Current Limit Level 2	The Profile 2 setting limits the current supplied in the motor throughout the Soft Start, Linear Speed, or Torque Ramp cycle. ⁽¹⁾	50...600% FLC	350% FLC

Parameter Name	Description	Options	Default Value
Initial Torque 2	Initial Torque 2 The initial reduced output voltage (torque) level for the Profile 2 Voltage Ramp to the motor is established and adjusted with this parameter. The torque level at which the ramp begins for Profile 2. NOTE: Not used for Torque Ramp.	0...90% LRT	70% LRT
Starting Torque 2	Starting Torque 2 For a Torque Ramp Start, the programmed initial or start torque point for Profile 2. This parameter is not used for other starting modes.	0...300% RMT	100% RMT
Max Torque 2	For Start Profile 2, the programmed torque end point for a Torque Ramp start. This parameter is not used for other starting modes.	0...300% RMT	250% RMT
Kickstart Time 2	For Start Profile 2, if required, a boost of current (torque) is provided to motor for this programmed time period. ⁽²⁾	0...2 s	0 s
Kickstart Level 2	For Start Profile 2, if required, this parameter programs the amount of current (torque) applied to the motor during Kickstart time. ⁽²⁾	750, 900, 1500, 1800, 3500, 3600 rpm	1800 rpm

- (1) Enter a value to limit the current but not low enough to inhibit the start cycle.
- (2) Available for Soft Start, Current Limit, and Torque Start modes. Set to zero to disable Kickstart.
- (3) Torque Ramp and Linear Speed Starting modes require you to perform a Motor Tuning Cycle. The SMC-50 controller does this automatically the first time the motor is run. You can also force this manually by setting the Force Tuning, Parameter 194, to TRUE (=1), which is accessed from the File Setup, Group Adv. Tuning or by pressing and holding the SMC-50 controller's Reset button for 10 seconds with the motor stopped.
- (4) You can also program a start delay time and will apply to both Start Profile 1 and Start Profile 2. The Start Delay parameter can be accessed from the Group Starting selection (see [Table 58](#)).

Start Options

Motor Winding Heater Function

The motor winding heater can be activated after it receives a valid Start command by either programming the Heating Time parameter to a non-zero value or by configuring a terminal block input to Motor Heater and activating that input prior to the Start command. The Motor Winding Heater function continues for the specified time or until the Motor Heater Input is deactivated, at which time the motor starts based on the prior Start command signal. The Motor Winding Heater function is disabled if the Heater Level parameter is set to zero, the Heater Time is set to zero, or the Input is inactive (or not configured) at the time of the Start command.

To program the Motor Winding Heater function, use the File Setup, Group Basic parameter list to configure the motor and the majority of the Start/Stop functions. See any of the previous programming sections for details based on the selected Start mode. The two key parameters (Heating Time and Heating Level), however, are in the File Setup Group Starting parameter list. See [Table 58 on page 168](#) for a basic understanding of accessing the Starting group. See [Table 66](#) for heating parameter information.

Table 66 - Heating Time and Heating Level Parameters

Parameter Name	Description	Options	Default Value
Heating Time	The amount of time the Motor Winding Heater function will remain engaged after receiving a valid Start command.	0...1000 s ⁽¹⁾	0 s
Heating Level	The percent Heating Level is sequentially applied to each winding.	0...100%	0 %

- (1) If the Terminal Block Input, configured to Motor Heater, is used to initiate the Motor Winding Heater function, Heating Time can be zero (0). The heater function is active after the terminal input is active and a start command.

Stop Options

SMB—Smart Motor Braking

To use the SMB function, the Stopping file group parameter set must be selected from FILE Setup group using the HIM (see [Table 58 on page 168](#)).

Table 67 - SMB Parameters

Parameter Name	Description	Options	Default Value
Stop Mode	Lets you select the Stop Mode. The mode must be programmed for SMB.	SMB	SMB
Stop Time	NOT used for SMB. SMB automatically controls the duration (stop time) of the braking current to the motor from the "running at speed" condition until a zero speed condition is reached (zero speed braking shutoff feature/function). ⁽¹⁾	0...999 s	0 s
Braking Current	The amount of braking current to be applied to the motor.	0...400% FLC	0 % FLC
Backspin Timer	The amount of time that must expire before another Start cycle can occur. The timer begins after the Stop maneuver is completed. All Start commands are ignored until the timer has expired. If the Start command is momentary and ends before the timer has expired, the motor does not start. This is used to prevent starting a motor that is still cycling.	0...999 seconds	0 s

(1) Programming a non-zero value for Stop Time overrides the SMB zero-speed detection feature/function and uses the exact time programmed for Stop Time to apply the programmed Braking Current to the motor. Doing this is useful in applications where detecting zero-speed is difficult (for example, a specific motor type or when the purpose is to reduce the number of overload trips associated with driving the motor to a complete stop). Setting the Stop Time to a specific value turns off braking current at a set time and each time a stopping maneuver is performed. To achieve an ideal Stop Time setting, use trial and error and always allow for some small coast time.

NOTE: Setting the Stop Time to a longer duration will cause braking current to be applied to a stopped motor and likely result in overload trips.

Slow Speed with Braking

The SMC-50 controller Slow Speed feature provides a slow speed jog capability for general-purpose positioning. This capability is typically used for system setup. Slow Speed can drive the motor within a range of 1...15% of normal speed in the forward or reverse direction without a reversing contactor. Braking from Slow Speed is also provided.

To use the Slow Speed with Braking feature, use the HIM. Navigate from the Port 00 DEV PARAM folder: File-Group, File: Setup, Group: Slow Speed. See [Table 58 on page 168](#) for detailed information.

Table 68 - Slow Speed with Braking Parameters

Parameter Name	Description	Options	Default Value
Slow Speed 1	Allow you to select Slow Speed 1 value for the application. ⁽¹⁾	-15...+15	+10
Slow Speed 2	Allow you to a second Slow Speed value for the application. ⁽¹⁾	-15...+15	+10
Slow Brake Current	The desired brake current to be applied from the programmed Slow Speed. ⁽²⁾	0...350% FLC	0 % FLC
Slow Speed Reference Gain	Lets you adjust the flux reference while the motor is running.	0.1...2.00	1.00
Slow Speed Transient Gain	Lets you adjust the control reference when transitioning between slow speed and any starting mode.	0.1...2.0	1.00

(1) The plus (+) or minus (-) sign determines the motor direction.

(2) A value of zero results in Coast-to-Stop.

Accu-Stop

This function combines the benefits of SMB and Preset Slow Speed features. For general-purpose positioning, the Accu-Stop function provides a brake from full speed to the preset slow speed setting, then a brake from Slow Speed or a Coast-to-Stop.

The Accu-Stop function is enabled whenever a control input is configured for Stop and another control input is configured for Slow Speed; the Stop Mode is configured for SMB and Slow Speed is configured. When the Slow Speed Input is enabled in this configuration, a SMB-to-Slow Speed occurs and Slow Speed continues until the Slow Speed Input is enabled.

To program Accu-Stop with the HIM, Setup Group Slow Speed and Setup Group Stopping must be used. See the two previous programming sections, [SMB—Smart Motor Braking](#) and [Slow Speed with Braking](#).

Motor Protection

The Motor Protection Group (see [Table 71 on page 182](#)) is used to program motor and starter protection functions. The Motor Protection Group is accessed from the HIM using the Port 00 DEV PARAM folder under the File-Group, File: Motor Protection selection sequence. By using this file group, the SMC-50 controller lets you individually enable, disable, or restart the motor and starter Faults and Alarms. Each of the 21 different Motor/Starter Protection Setup groups (for example, Overload, Underload, Jam, Stall, Voltage Unbal, etc.) has at least one selection for Fault Enable, Alarm Enable, and Restart Enable. For bit assignment definitions for the related Faults and Alarms, see [Table 25](#) and [Table 26](#).

IMPORTANT The majority of parameters have a Fault and an Alarm setting.

To modify any Fault or Alarm bit for enable/disable functionality, perform the following steps.

1. From the Motor Protection Group, select the desired group.

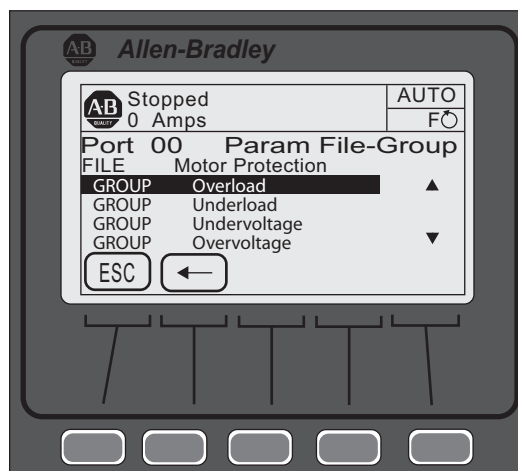

2. Press ENTER (number 5 from keypad) to display the associated bit parameters.

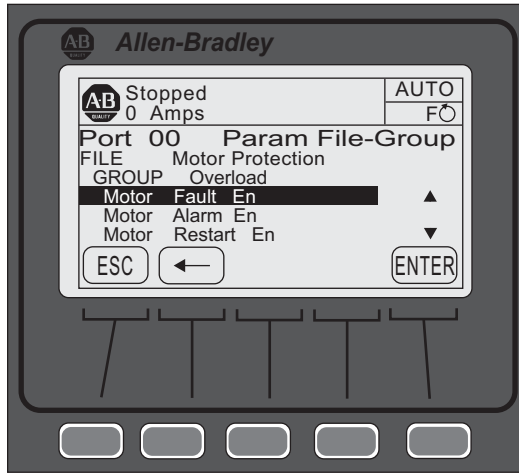

3. Select the desired 16 bit field, then press EDIT.

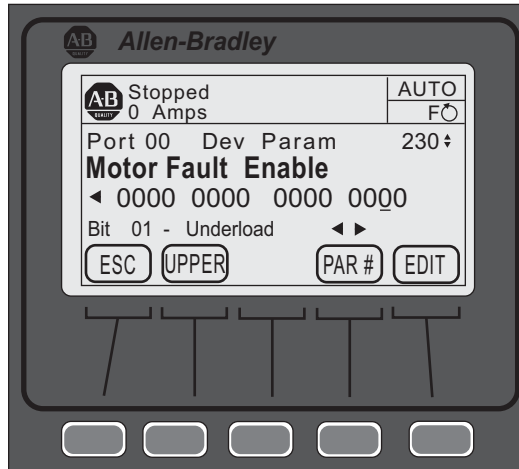

TIP The UPPER and LOWER soft key allows for switching between the upper (16 to 31) and lower (0 to 16) bits.

4. Use the right or left arrow to move the cursor to the desired bit. The bit function is displayed at the bottom of the screen.

5. Enter a 1 to enable or 0 to disable, then press ENTER to load the change into the controller.

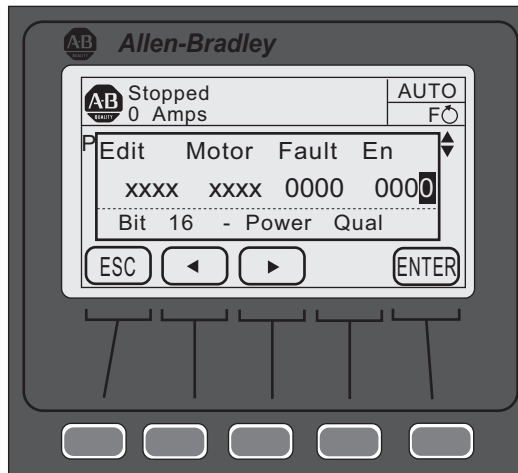

For details concerning motor and controller (Fault and Alarm) protection parameters, see [Chapter 5](#).

Parameter File-Group Structure

The five parameter File-Groups are structured as shown below. The access levels for each parameter are abbreviated as follows:

- M—Monitoring,
- B—Basic,
- A—Advanced, and
- MBA—Monitoring, Basic, and Advanced.

Table 69 - Monitoring Group

Monitoring File Group Parameters								
Metering Basic (MBA)	Metering Volts (MBA)	Metering Current (MBA)	Metering Power (MBA)		Start Stats (MBA)	Monitoring (MBA)	Power Quality (MBA)	
Volts P-P Ave	Volts P-P Ave	Current Ave	Real Power	Apparent Power	Start Time 1	Elapsed Time	THD Va	
Volts P-N Ave	Volts Phase A-B	Current Phase A	Real Power A	Apparent Power A	Start Time 2	Elapsed Time 2	THD Vb	
Current Average	Volts Phase B-C	Current Phase B	Real Power B	Apparent Power B	Start Time 3	Running Time	THD Vc	
Torque	Volts Phase C-A	Current Phase C	Real Power C	Apparent Power C	Start Time 4	Energy Savings	THD Vave	
Motor Speed	Volts P-N Ave	Current Imbal	Real Demand	Apparent Demand	Start Time 5	Motor Therm Usage	THD Ia	
Power Factor	Volts Phase A-N		Max Real Demand	Max Apparent Demand	Peak Current 1	Time to OL Trip	THD Ib	
Real Power	Volts Phase B-N		Reactive Power	Power Factor	Peak Current 2	Time to OL Reset	THD Ic	
Reactive Power	Volts Phase C-N		Reactive Power A	Power Factor A	Peak Current 3	Time to PM	THD Iave	
Apparent Power	Volts Unbal		Reactive Power B	Power Factor B	Peak Current 4	Starts to PM		
Real Energy			Reactive Power C	Power Factor C	Peak Current 5	Total Starts		
Reactive Energy +			Reactive Demand					Product Status
Reactive Energy -			Max Reactive Demand					
Apparent Energy								
Meter Reset								

Table 70 - Setup File Group

Setup File Group Parameters									
Basic (BA)		Starting (BA)	Stopping (BA)	Slow Speed	Dual Ramp (BA)	Advanced	I/O (BA)	Advanced Tuning	
Motor Config	Input 2	Starting Mode	Stop Mode	Slow Speed 1 (BA)	Starting Mode 2	Pump Pedestal (A)	Input 1	Force Tuning (A)	Phase Shift 0% (A)
Line Voltage	Aux 1 Config	Ramp Time	Stop Time		Ramp Time 2	Brake Load Type (A)	Input 2	Starter R	Phase Shift 10% (A)
Starting Mode	Aux 2 Config	Cur Limit Level	Braking Current	Slow Speed 2 (BA)	Cur Limit Level 2	High Eff Brake (A)	Aux 1 Config	Total R	Phase Shift 20% (A)
	Overload Class	Initial Torque	Backspin Timer		Initial Torque 2	UTS Level (A)	Aux 1 Invert	Coupling Factor	Phase Shift 30% (A)
Ramp Time	Service Factor	Starting Torque		Slow Brake Cur (BA)	Starting Torque 2	Stall Position (A)	Aux 1 On Delay	Inductance	Phase Shift 40% (A)
Initial Torque		Max Torque			Max Torque 2	Stall Level (A)	Aux 1 Off Delay	Speed PGain (A)	Phase Shift 50% (A)
Max Torque	Kickstart Time	SS Ref Gain (A)		Kickstart Time 2	V Shut Off Level (A)	Aux 2 Config	Transient Gain (A)	Phase Shift 60% (A)	
Cur Limit Level	Kickstart Level			Kickstart Level 2	I Shut Off Level (A)	Aux 2 Invert	Phase Shift 70% (A)		
Stop Mode	Starting Torque	Heating Time		SS Trans Gain (A)		Notch Maximum (A)	Aux 2 On Delay	Transient Zero (A)	Phase Shift 80% (A)
		Heating Level				Timed Start (A)	Aux 2 Off Delay	Phase Shift 90% (A)	
Stop Time	Max Torque	Start Delay				Bypass Delay (A)	Aux Control	Transient Mag (A)	Phase Shift 100% (A)
Input 1	Rated Torque					Energy Saver (BA)			
	Rated Speed					Demand Period (BA)		Pings (A)	
								Num of Periods (BA)	

Table 71 - Motor Protection Group

Motor Protection File Group Parameters							
Overload (BA)	Underload (BA)	Undervoltage (BA)	Overvoltage (BA)	Jam (BA)	Stall (BA)	Real Power (BA)	Reactive + Power (BA)
Motor Fault Enable	Motor Fault Enable	Starter Fault Enable	Starter Fault Enable	Motor Fault Enable	Motor Fault Enable	Motor Fault Enable	Motor Fault Enable
Motor Alarm Enable	Motor Alarm Enable	Starter Alarm Enable	Starter Alarm Enable	Motor Alarm Enable	Motor Alarm Enable	Motor Alarm Enable	Motor Alarm Enable
Motor Restart Enable	Motor Restart Enable	Starter Restart Enable	Starter Restart Enable	Motor Restart Enable	Motor Restart Enable	Motor Restart Enable	Motor Restart Enable
Overload Class	Underload F Level			Jam F Level	Stall Delay	MWatts Ov F Level	+MVAR Ov F Level
Overload Class 2	Underload F Delay	Undervolt F Level	Overvolt F Level	Jam F Delay		MWatts Ov F Delay	+MVAR Ov F Delay
Service Factor	Underload A Level	Undervolt F Delay	Overvolt F Delay	Jam A Level		MWatts Ov A Level	+MVAR Ov A Level
Motor FLC	Underload A Delay	Undervolt A Level	Overvolt A Level	Jam A Delay		MWatts Ov A Delay	+MVAR Ov A Delay
OL Reset Level		Undervolt A Delay	Overvolt A Delay			MWatts Un F Level	+MVAR Un F Level
OL Shunt Time		MWatts Un F Delay	+MVAR Un F Delay				
OL Inhibit Time		MWatts Un A Level	+MVAR Un A Level				
Overload A Lvel		MWatts Un A Delay	+MVAR Un A Delay				
Reactive - Power (BA)	Apparent Power (BA)	Leading PF (BA)	Lagging PF (BA)	Voltage Unbal (BA)	Current Imbal (BA)	Voltage THD (BA)	Current THD (BA)
Motor Fault Enable	Motor Fault Enable	Motor Fault Enable	Motor Fault Enable	Starter Fault Enable	Motor Fault Enable	Starter Fault Enable	Motor Fault Enable
Motor Alarm Enable	Motor Alarm Enable	Motor Alarm Enable	Motor Alarm Enable	Starter Alarm Enable	Motor Alarm Enable	Starter Alarm Enable	Motor Alarm Enable
Motor Restart Enable	Motor Restart Enable	Motor Restart Enable	Motor Restart Enable	Starter Restart Enable	Motor Restart Enable	Starter Restart Enable	Motor Restart Enable
-MVAR Ov F Level	MVA Ov F Level	Lead PF F Level	Lag PF F Level		Current Imbal F Level		THD I F Level
-MVAR Ov F Delay	MVA Ov F Delay	Lead PF F Delay	Lag PF F Delay	Voltage Unbal F Level	Current Imbal F Delay	THD V F Level	THD I F Delay
-MVAR Ov A Level	MVA Ov A Level	Lead PF A Level	Lag PF A Level			THD V F Delay	THD I A Level
-MVAR Ov A Delay	MVA Ov A Delay	Lead PF A Delay	Lag PF A Delay	Voltage Unbal F Delay	Current Imbal A Level	THD V A Level	THD I A Delay
+MVAR Un F Level	MVA Un F Level	Lead PF F Level	Lag PF F Level			THD V A Delay	
-MVAR Un F Delay	MVA Un F Delay	Lead PF F Delay	Lag PF F Delay	Voltage Unbal A Level	Current Imbal A Delay		
-MVAR Un A Level	MVA Un A Level	Lead PF A Level	Lag PF A Level				
-MVAR Un A Delay	MVA Un A Delay	Lead PF A Delay	Lag PF A Delay	Voltage Unbal A Delay			

Motor Protection File Group Parameters				
Line Frequency (BA)	Maintenance	History (MBA)	Restart (BA)	Locked Rotor (BA)
Starter Fault Enable	Motor Fault Enable (BA)	Fault 1	Motor Restart Enable	Motor Fault Enable
Starter Alarm Enable	Motor Alarm Enable (BA)	Fault 2	Starter Restart Enable	Motor Alarm Enable
Starter Restart Enable	Motor Restart Enable (BA)	Fault 3	Restart Attempts	Motor Restart Enable
Frequency High F Level	PM Hours (BA)	Fault 4	Restart Delay	Locked Rotor F Level
Frequency High F Delay	PM Starts (BA)	Fault 5		Locked Rotor F Delay
Frequency High A Level	Time to PM (MBA)	Alarm 1		Locked Rotor A Level
Frequency High A Delay	Starts to PM (MBA)	Alarm 2		Locked Rotor A Delay
Frequency Low F Level	Starts per Hour (MBA)	Alarm 3		
Frequency Low F Delay		Alarm 4		
Frequency Low A Level		Alarm 5		
Frequency Low A Delay				

Table 72 - Communications Group Parameters

Communications File Group Parameters		
Communications Masks (BA)	Data Links (BA)	
Logic Mask	Data In A1	Data Out A1
Logic Mask Act	Data In A2	Data Out A2
Write Mask Cfg	Data In B1	Data Out B1
Write Mask Act	Data In B2	Data Out B2
Port Mask Act	Data In C1	Data Out C1
	Data In C2	Data Out C2
	Data In D1	Data Out D1
	Data In D2	Data Out D2

Table 73 - Utility Group Parameters

Utility File Group Parameters		
Preferences	Motor Data	Expansion (MBA)
Language (BA)	Motor Connection (MBA)	Expansion A Configuration
Fan Configuration (BA)	Line Voltage (BA)	Expansion A Configuration
Motor Configuration (BA)	Motor FLC (BA)	Expansion A Configuration
Parameter Management (A)	Rated Torque (BA)	
	Rated Speed (Ba)	
	User CT Ratio (A)	
	Factory CT Ratio (A)	
	Voltage Ratio (A)	
	Parameter Management (A)	

DeviceLogix parameters are Parameters 335...346, located in the parameter linear list. See [Appendix C](#) for additional information and programming examples.

Table 74 - SMC-50 Controller Parameter Linear List—Parameter 1...67

Number ⁽¹⁾	Name		Number ⁽¹⁾	Name	
1 (M, B, A)	Voltage	P-P Ave	35 (M, B, A)	THD	V _a
2 (M, B, A)	Volts Phase	A-B	36 (M, B, A)		V _b
3 (M, B, A)		B-C	37 (M, B, A)		V _c
4 (M, B, A)		C-A	38 (M, B, A)		V _{ave}
5 (M, B, A)		Current Average	39 (M, B, A)		I _a
6 (M, B, A)	Current Phase	A	40 (M, B, A)		I _b
7 (M, B, A)		B	41 (M, B, A)		I _c
8 (M, B, A)		C	42 (M, B, A)		I _{ave}
9 (M, B, A)	Torque	43 (M, B, A)	Product Status		
10 (M, B, A)	Real Power	44 (B, A)	Motor Config		
11 (M, B, A)	Real Energy	45 (M, B, A)	Motor Connection		
12 (M, B, A)	Elapsed Time	46 (B, A)	Line Voltage		
13 (M, B, A)	Elapsed Time 2	47 (B, A)	Rated	Torque	
14 (M, B, A)	Running Time	48 (B, A)		Speed	
15 (M, B, A)	Energy Savings	49 (B, A)	Starting Mode		
16 (M, B, A)	Meter Reset	50 (B, A)	Ramp Time		
17 (M, B, A)	Power Factor	51 (B, A)	Initial Torque		
18 (M, B, A)	Motor Therm Usage	52 (B, A)	Maximum Torque		
19 (M, B, A)	Time to OL	Trip	53 (B, A)	Current Limit Level	
20 (M, B, A)		Reset	54 (B, A)	Kickstart	Time
21 (M, B, A)	Time to PM	55 (B, A)	Level		
22 (M, B, A)	Starts to PM	56 (B, A)	Input	1	
23 (M, B, A)	Total Starts	57 (B, A)		2	
24 (M, B, A)	Start Time	1	58 (B, A)	Starting Mode 2	
25 (M, B, A)		2	59 (B, A)	Ramp Time 2	
26 (M, B, A)		3	60 (B, A)	Initial Torque 2	
27 (M, B, A)		4	61 (B, A)	Maximum Torque 2	
28 (M, B, A)		5	62 (B, A)	Current Limit Level 2	
29 (M, B, A)	Peak Current	1	63 (B, A)	Kickstart	Time 2
30 (M, B, A)		2	64 (B, A)		Level 2
31 (M, B, A)		3	65 (B, A)	Stop	Mode
32 (M, B, A)		4	66 (B, A)		Time
33 (M, B, A)		5	67 (B, A)	Backspin Timer	
34 (M, B, A)	Motor Speed				

(1) M, B, A = Access Level; see [Parameter Access Level Modification Using the HIM](#).

Table 75 - SMC-50 Controller Parameter Linear List—Parameter 68...135

Number ⁽¹⁾	Name	Number ⁽¹⁾	Name	
68 (A)	Pump Pedestal	102 (B, A)	Overvolt	
69 (B, A)	Braking Current	103 (B, A)		
70 (B, A)	Brake Load Type	104 (B, A)		
71 (B, A)	High Eff Brake	105 (B, A)		
72 (B, A)	Slow Speed 1	106 (B, A)	Volt Unbal	
73 (B, A)	Slow Brake Current	107 (B, A)		
74 (—)	Reserved	108 (B, A)		
75 (B, A)	Overload Class	109 (B, A)		
76 (B, A)	Overload Class 2	110 (B, A)	Cur Imbal	
77 (B, A)	Service Factor	111 (B, A)		
78 (B, A)	Motor FLC	112 (B, A)		
79 (B, A)	Motor FLC 2	113 (B, A)		
80 (B, A)	OL Reset Level	114 (B, A)	Jam	
81 (B, A)	OL Shunt Time	115 (B, A)		
82 (B, A)	OL Inhibit Time	116 (B, A)		
83 (B, A)	Overload A Lvl	117 (B, A)		
84 (B, A)	Locked Rotor	F Lvl	118 (B, A)	THD V
85 (B, A)		F Dly	119 (B, A)	
86 (B, A)	Underload	F Lvl	120 (B, A)	
87 (B, A)		F Dly	121 (B, A)	
88 (B, A)		A Lvl	122 (B, A)	
89 (B, A)		A Dly	123 (B, A)	
90 (B, A)	MWatts Ov	F Lvl	124 (B, A)	THD I
91 (B, A)		F Dly	125 (B, A)	
92 (B, A)		A Lvl	126 (B, A)	PM Hours
93 (B, A)		A Dly	127 (B, A)	PM Starts
94 (B, A)	MWatts Un	F Lvl	128 (B, A)	Starts Per Hour
95 (B, A)		F Dly	129 (B, A)	Frequency High F Lvl
96 (B, A)		A Lvl	130 (B, A)	Frequency Low F Lvl
97 (B, A)		A Dly	131 (B, A)	Frequency High A Lvl
98 (B, A)	Undervolt	F Lvl	132 (B, A)	Frequency Low A Lvl
99 (B, A)		F Dly	133 (B, A)	Restart Attempts
100 (B, A)		A Lvl	134 (B, A)	Restart Delay
101 (B, A)		A Dly	135 (B, A)	Starter Restart Enable

(1) M, B, A = Access Level; see [Parameter Access Level Modification Using the HIM](#).

Table 76 - SMC-50 Controller Parameter Linear List—Parameter 136...205

Number ⁽¹⁾	Name	Number ⁽¹⁾	Name	
136 (B, A)	Starter Fault Enable	171 (A)	Factory CT Ratio	
137 (B, A)	Starter Alarm Enable	172 (B, A)	Aux 1	
138 (M, B, A)	Fault	1		Config
139 (M, B, A)		2		Invert
140 (M, B, A)		3		On Delay
141 (M, B, A)		4	Off Delay	
142 (M, B, A)		5	Aux 2	
143 (M, B, A)	1	Config		
144 (M, B, A)	2	Invert		
145 (M, B, A)	3	On Delay		
146 (M, B, A)	Alarm	4	Off Delay	
147 (M, B, A)		5	Aux Control	
148 (B, A)		Logic Mask	183 (A)	Language
149 (B, A)	Logic Mask Act	184 (A)	Start Delay	
150 (B, A)	Write Mask Cfg	185 (A)	Timed Start	
151 (B, A)	Write Mask Act	186 (A)	V Shut Off Level	
152 (B, A)	Port Mask Act	187 (A)	I Shut Off Level	
153 (B, A)	Data In	A1	Stall	
154 (B, A)		A2		Level
155 (B, A)		B1		Delay
156 (B, A)		B2	Position	
157 (B, A)		C1	Notch Maximum	
158 (B, A)		C2	Notch Position	
159 (B, A)		D1	Bypass Delay	
160 (B, A)		D2	Energy Saver	
161 (B, A)		Data Out	A1	Force Tuning
162 (B, A)			A2	Stator R
163 (B, A)	B1		Total R	
164 (B, A)	B2		Coupling Factor	
165 (B, A)	C1		Inductance	
166 (B, A)	C2		Speed PGain	
167 (B, A)	D1		Transient	
168 (B, A)	D2			Gain
169 (A)	Voltage Ratio	204 (A)	Zero	
170 (A)	User CT Ratio	205 (A)	Mag	
			Ping Degree	
			Pings	
			Phase Shift 0	

(1) M, B, A = Access Level; see [Parameter Access Level Modification Using the HIM](#).

Table 77 - SMC-50 Controller Parameter Linear List—Parameter 206...277

Number ⁽¹⁾	Name	Number ⁽¹⁾	Name		
206 (A)	Phase Shift	10	242 (B, A)		
207 (A)		20	243 (B, A)		
208 (A)		30	244 (B, A)		
209 (A)		40	245 (B, A)		
210 (A)		50	246 (B, A)		
211 (A)	Phase Shift	60	247 (B, A)		
212 (A)		70	248 (B, A)		
213 (A)		80	249 (B, A)		
214 (A)		90	250 (B, A)		
215 (A)		100	251 (B, A)		
216 (M, B, A)	Board Temp	252 (B, A)	Lead PF		
217 (B, A)	Exp 7 Config	253 (B, A)			
218 (B, A)	Exp 8 Config	254 (B, A)			
219 (B, A)	Exp 9 Config	255 (B, A)			
220 (B, A)	Heating	Time	256 (B, A)	Lag PF	
221 (B, A)		Level	257 (B, A)		
222 (B, A)	Fan	Config	258 (B, A)		
223 (M, B, A)		Connection	259 (B, A)		
224 (M, B, A)	Line Frequency	260 (B, A)	Un F Lvl		
225 (B, A)	Freq High	F Dly			261 (B, A)
226 (B, A)		A Dly			262 (B, A)
227 (B, A)	Freq Low	F Dly			263 (B, A)
228 (B, A)		A Dly	264 (B, A)		
229 (A)	Parameter Management	265 (M, B, A)	Motor Restart En		
230 (B, A)	Motor	Fault En	266 (M, B, A)	Voltage	
231 (B, A)		Alarm En	267 (M, B, A)		
232 (B, A)	+MVAR ⁽²⁾	Ov F Lvl	268 (M, B, A)		P-N Ave
233 (B, A)		Ov F Dly	269 (M, B, A)	Volts Phase	
234 (B, A)		Ov A Lvl	270 (M, B, A)		A-N
235 (B, A)		Ov A Dly	271 (M, B, A)		B-N
236 (B, A)		Un F Lvl	272 (M, B, A)	C-N	
237 (B, A)	Un F Dly	273 (M, B, A)	Real Power		
238 (B, A)	Un A Lvl	274 (M, B, A)		A	
239 (B, A)	Un A Dly	275 (M, B, A)		B	
240 (B, A)	MVA	Ov F Lvl	276 (M, B, A)	Reactive Power	
241 (B, A)		Ov F Dly	277 (M, B, A)		C

(1) M, B, A = Access Level; see [Parameter Access Level Modification Using the HIM](#).

(2) The "+" for MVAR indicates power consumed.

Table 78 - SMC-50 Controller Parameter Linear List—Parameter 278...333

Number ⁽¹⁾	Name		Number ⁽¹⁾	Name	
278 (M, B, A)	Reactive Energy	C ⁽³⁾	307 (A)	SS Ref Gain	
279 (M, B, A)		P ⁽⁴⁾	308 (A)	SS Trans Gain	
280 (B, A)	Reactive Energy		309 (M, B, A)	Input Status	
281 (M, B, A)	Reactive Demand		310 (B, A)	Locked Rotor	A Lvl
282 (M, B, A)	Max Reactive Demand		311 (B, A)		A Dly
283 (M, B, A)	Apparent Power	A	312 (A)	Product Command	
284 (M, B, A)		B			
285 (M, B, A)		C	313 (B, A)	Rebalance Level	
286 (M, B, A)	Apparent Power		314 (M, B, A)	Peak Voltage	A
287 (M, B, A)	Apparent Energy		315 (M, B, A)		B
288 (M, B, A)	Apparent Demand		316 (M, B, A)		C
289 (M, B, A)	Max Apparent Demand		317 (M, B, A)	Peak Current	A
290 (B, A)	Demand Period		318 (M, B, A)		B
291 (B, A)	Number of Periods		319 (M, B, A)		C
292 (M, B, A)	Power Factor	A	320 (M, B, A)	Phase A-B Voltage	
293 (M, B, A)		B	321 (M, B, A)	Phase B-C Voltage	
294 (M, B, A)		C	322 (M, B, A)	Phase C-A Voltage	
295 (M, B, A)	Current Imbal		323 (M, B, A)	Phase A Current	
296 (M, B, A)	Voltage Unbal		324 (M, B, A)	Phase B Current	
297 (B, A)	-MVAR ⁽²⁾	Ov F Lvl	325 (M, B, A)	Snap Shot	Phase C Current
298 (B, A)		Ov F Dly	326 (M, B, A)		Power Factor
299 (B, A)		Ov A Lvl	327 (M, B, A)		Motor Thermal Usage
300 (B, A)		Ov A Dly	328 (M, B, A)		Motor Speed
301 (B, A)		Un F Lvl	329 (M, B, A)		THD Voltage Average
302 (B, A)		Un F Dly	330 (M, B, A)		THD Current Average
303 (B, A)		Un A Lvl	331 (M, B, A)		Product Status
304 (B, A)		Un A Dly	332 (M, B, A)		Board Temp
305 (B, A)	Starting Torque		333 (M, B, A)	Line Frequency	
306 (B, A)	Starting Torque 2		334 (M, B, A)	Restart Auto	
307 (A)	SS Ref Gain				

- (1) M, B, A = Access Level; see [Parameter Access Level Modification Using the HIM](#).
- (2) The "-" for MVAR indicates power generated.
- (3) C=Consumed
- (4) P=Produced

Table 79 - SMC-50 Controller Parameter Linear List—Parameter 334...350

Number ⁽¹⁾	Name		Number ⁽¹⁾	Name	
335 (M, B, A)	DeviceLogix	DLX Input 1	345 (M, B, A)	DeviceLogix	DLX Command
336 (M, B, A)		DLX Input 2	346 (M, B, A)		DLX Status
337 (M, B, A)		DLX DL Input 1	347 (M, B, A)	Load Type	
338 (M, B, A)		DLX DL Input 2	348 (M, B, A)	Ref Source	
339 (M, B, A)		DLX DL Input 3	349 (M, B, A)	Output V Ref	
340 (M, B, A)		DLX DL Input 4	350 (M, B, A)	Slow Speed 2	
341 (M, B, A)	DeviceLogix	DLX DL Input 5			
342 (M, B, A)		DLX DL Input 6			
343 (M, B, A)		DLX Output 1			
344 (M, B, A)		DLX Output 2			

- (1) M, B, A = Access Level; see [Parameter Access Level Modification Using the HIM](#).

SMC-50 Controller Option Module Configuration

Basic Configuration using the HIM

When you plug an SMC-50 controller Option Module into one of the three available ports (07, 08, or 09), you may need to configure the option module parameters. These parameters reside in the option module through one of the controller ports (07, 08, or 09) and are not included in the SMC-50 controller Controller (Port <00>) parameter list.

Perform the following steps to access the option module parameters using the HIM.

TIP Before proceeding with these steps: Take note of the SMC-50 controller port number (07, 08, or 09) that the option module is connected to.

1. Press the FOLDERS single function key.
2. Use the forward or back arrow until the PORTS folder screen is displayed.

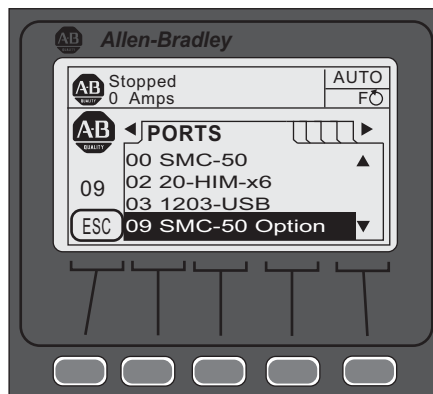

3. Use the up or down arrow until the noted port number of the option module is displayed. The HIM displays the HOST PARM file screen and indicates the option module port controller number below the AB logo.

Ensure that the correct port number is displayed before you modify the option module parameter

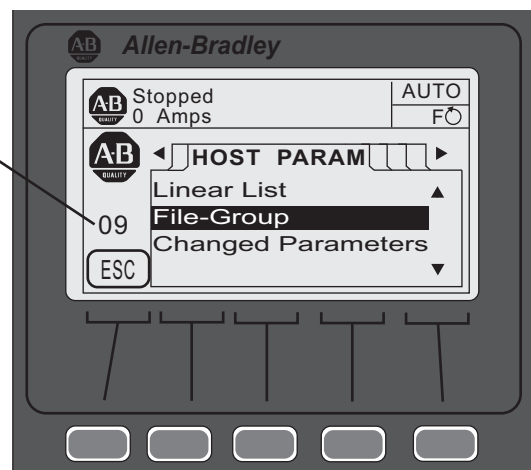

4. Ensure the correct port number is displayed, then configure the parameters using either the Linear List or File-Group selection.

TIP Parameters can be restored to factory defaults using its respective Parameter Management parameter or the Set Defaults function from the HIM's memory screen. Ensure the correct port number of the device to be restored is displayed before restoring.

For additional information using the FOLDERS function of the HIM, see the 20-HIM-A6 user manual, publication [20HIM-UM001](#).

150-SM4 Digital I/O Option Module

In addition to the two on-board 24V DC input and two auxiliary relay outputs of the SMC-50 controller, the 150-SM4 Digital I/O Option Module has four 120...240V AC inputs and three auxiliary relay outputs. You can use these inputs and outputs for control functions.

Configure 120...240V AC Inputs

TIP Before proceeding with the following steps, perform steps [1](#) through [4](#) in [Basic Configuration using the HIM](#).

1. From the File-Group screen, press ENTER (number 5 on the keypad). The four inputs are displayed.

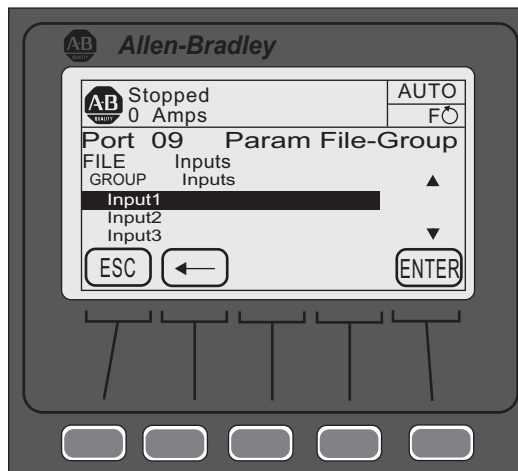

2. Use the up or down arrow to select the input, then press ENTER (number 5 on the keypad). The display will show the current setting of the input.
3. Press the EDIT soft key to change the selected input function.
4. Use the up or down arrow to select the desired function (for example, Start, Stop, Coast, Slow Speed, etc.), then press the ENTER soft key to load the selection. If necessary, use the back arrow to return to the previous selection.

TIP For a complete list of 150-SM4 parameters, see the [Digital I/O Option Module Parameter List on page 192](#).

For additional information using the FILE GROUP function of the HIM, see the 20-HIM-A6 user manual, publication [20HIM-UM001](#).

Configure Auxiliary Relay Outputs

TIP Before proceeding with the following steps, perform steps [1](#) through [4](#) in [Basic Configuration using the HIM](#).

1. Use the up or down arrow to select the one of the Aux Outputs, then press ENTER (number 5 on the keypad).

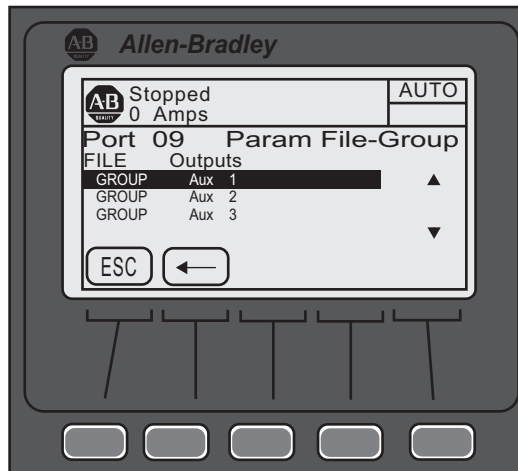

2. Select one of the four configuration options (Aux X Config, Aux X Invert, Aux X On Delay, or Aux X Off Delay), then press ENTER (keypad or soft key).
3. Modify the auxiliary relay output as desired. If necessary, use the back arrow to return to the previous selection.

Digital I/O Option Module Parameter List

The allowable selections for the 150-SM4 are listed in [Table 80](#).

Table 80 - 150-SM4 Parameters

Parameter Number ⁽¹⁾	Name	Min/Max Values	Default Value	Access	Units	
X.1	Module Status	Bit 0 = Module Ready/Disabled Bit 1 = Input 1 Status Bit 2 = Input 2 Status Bit 3 = Input 3 Status	Bit 4 = Input 4 Status Bit 5 = Aux 1 Status Bit 6 = Aux 2 Status Bit 7 = Aux 3 Status	—	R	0 = Disabled OFF 1 = Enabled ON
X.2	Input 1	Disable	Dual Ramp	Disable	R/W	NA
X.3	Input 2	Start	OL Select			
X.4	Input 3	Coast	Fault			
X.5	Input 4	Stop Option	Fault NC			
		Start/Coast	Clear Fault			
		Start/Stop	Emerg Run			
		Slow Speed	Motor Heater			
X.6	Aux 1 Config	[Normal] UTS (Up-to-Speed) Fault Alarm Ext Bypass Ext Brake	DeviceLogix Aux Control ⁽²⁾ Network 1 Network 2 Network 3 Network 4 Fan Control	Normal	R/W	NA
X.7	Aux 1 Invert	Disable Enable		Disable	R/W	
X.8	Aux 1 On Delay	0.0 . . . 10.0		0.0	R/W	seconds
X.9	Aux 1 Off Delay	0.0 . . . 10.0		0.0	R/W	seconds
X.10	Aux 2 Config	[Normal] UTS (Up-to-Speed) Fault Alarm Ext Bypass Ext Brake	DeviceLogix Aux Control ⁽²⁾ Network 1 Network 2 Network 3 Network 4 Fan Control	Normal	R/W	NA
X.11	Aux 2 Invert	Disable Enable		Disable	R/W	NA
X.12	Aux 2 On Delay	0.0 . . . 10.0		0.0	R/W	seconds
X.13	Aux 2 Off Delay	0.0 . . . 10.0		0.0	R/W	seconds
X.14	Aux 3 Config	[Normal] UTS (Up-to-Speed) Fault Alarm Ext Bypass Ext Brake	DeviceLogix Aux Control ⁽²⁾ Network 1 Network 2 Network 3 Network 4 Fan Control	Normal	R/W	NA
X.15	Aux 3 Invert	Disable Enable		Disable	R/W	NA
X.16	Aux 3 On Delay	0.0 . . . 10.0		0.0	R/W	seconds
X.17	Aux 3 Off Delay	0.0 . . . 10.0		0.0	R/W	seconds
X.18	Parameter Mgmt	Ready Factory Default		Ready	R/W	NA

(1) "X" indicates the port number (07, 08, or 09) the 150-SM4 is connected to the SMC-50 controller. This port number is displayed on the HIM screen below the Allen-Bradley brand logo.

(2) An auxiliary output configured for Aux Control using the AuxX Config parameter is under control of its associated bit from the AuxControl, Parameter 180. See [150-SM6 PCM Information on page 277](#) for bit assignments. This function enables forcing an output, ON or OFF.

150-SM6 Parameter Configuration Option Module

The 150-SM6 Parameter Configuration Option Module is used to configure a select group of parameters. The option module itself requires no user configuration. The option module status and switch positions that configure its select parameters can be read using the HIM or PC software.

TIP Only one 150-SM6 is allowed per SMC-50 controller.

To read the 150-SM6 switch positions, follow the steps in [Basic Configuration using the HIM on page 189](#). When Linear List is selected, use the up or down arrow to view the module switch positions.

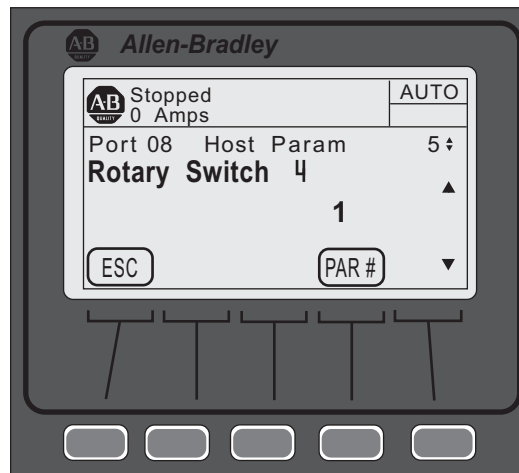

[Table 81](#) provides the parameter detail of the 150-SM6.

Table 81 - 150-SM6 Parameters

Parameter		Min./Max.	Access	Units
Number ⁽¹⁾	Name			
X.1	Module Status	Ready	R	1=Ready 0=Disabled
X.2	Rotary Switch 1 ⁽²⁾ (Initial Torque)	0.0...15.0	R	0...1.5=0...F
X.3	Rotary Switch 2 ⁽²⁾ (Current Limit)			
X.4	Rotary Switch 3 ⁽²⁾ (Ramp Time)			
X.5	Rotary Switch 4 ⁽²⁾ (Stop Time)			
X.6	Rotary Switch 5 ⁽²⁾ (Motor FLC)			
X.7	Device Config	0.0...255.0	R/W	Bit Numbered ⁽³⁾
X.8	Protect Config			
X.9	I/O Config			

(1) "X" indicates the port number (07, 08, or 09) the 150-SM6 is connected to the SMC-50 controller. This port number is displayed on the HIM screen below the AB brand logo.

(2) For 150-SM6: Rotary Switch 1 = S1, Rotary Switch 2 = S2, etc. Rotary switch positions equal 1 to F. As displayed on the HIM, A=10, B=11, C=12, and so on.

(3) Bit 0 and 1 values represent the ON/OFF switch positions within the associated switch bank (for example, Device Config) where 0=OFF and 1=ON.

NOTE: Switch #1=Bit 0, Switch #2=Bit 1, etc. as displayed on the HIM.

For switch setting details, see [Table 83](#) through [Table 87](#).

150-SM2 PTC, Ground Fault, and External Current Transformer Module

The 150-SM2 Option Module provides simultaneous interface capability to three different types of external sensing devices which can be used by the SMC-50 controller for certain application conditions. When installing the 150-SM2 into the SMC-50 controller, the following installation requirements **must** be followed:

- Only one 150-SM2 can be installed in one SMC-50 controller.
- The 150-SM2 **must** reside in port 7 or 8 only. **DO NOT** use port 9 with the 150-SM2.
- When the external CT function is enabled through the 150-SM2 CT Enable Bit, the external CT is calibrated by the SMC-50 controller for scaling, phase shift, and inversion. The calibration cycle will automatically occur:
 - before the first START occurs after the 150-SM2 installation and when the CT Enable, Parameter X.12, = Enable,
 - after a Load Defaults occurs, and
 - when you force tuning of the SMC-50 controller through the Force Tuning, Parameter 194, or the HOLD TO TEST button on the SMC-50 controller is held for > 10 seconds when stopped.

To configure the 150-SM2, follow the steps in [Basic Configuration using the HIM on page 189](#) then proceed with the following steps.

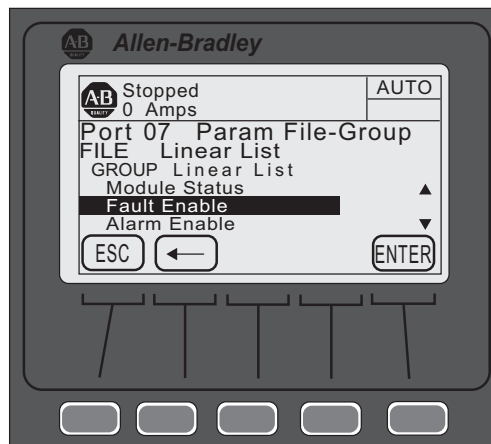

1. Using the File-Group selection, press ENTER (number 5 on the keypad) until the Group Linear List is displayed.
2. Use the up or down arrow to scroll to the desired parameter, then press ENTER.

If the parameter is bit configured (for example, Fault Enable):

- a. Use the left or right arrow to move to the bit location that needs to be modified. The bit function is displayed at the bottom of the screen.
- b. Press EDIT to move to the edit screen.
- c. Change the bit assignment, then press EDIT.

If the parameter is **not** bit configured (for example, Turns Ratio):

- a. Press the EDIT.
- b. Change the value within the displayed limits, then press ENTER to load the parameter contents into memory.

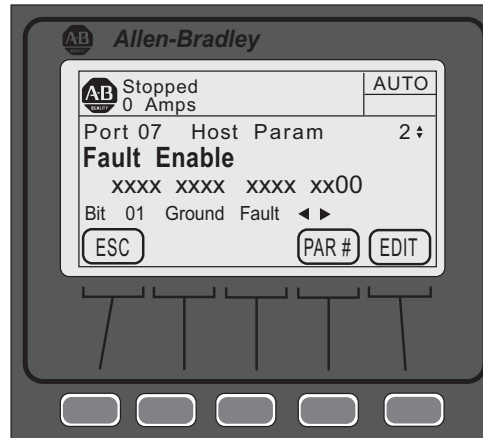

[Table 82](#) provides the parameter detail of the 150-SM2.

Table 82 - 150-SM2 Parameters

Parameter		Min/Max Values	Default Value	Access	Units
Number ⁽¹⁾	Name				
X.1	Module Status	Bit 0 = Module Ready Bit 1 = PTC Bit 2 = CT Loss	—	R	Bit = 0 Disable Bit = 1 Enable
X.2	Fault Enable	Bit 0 = PTC Bit 1 = Ground Fault	—	R/W	Bit = 0 Disable Bit = 1 Enable
X.3	Alarm Enable				
X.4	Restart Enable				
X.5	Turns Ratio ⁽²⁾	100...2000	1000	R/W	NA
X.6	Ground Fault Level ⁽³⁾	0.00...5.00	2.5	R/W	Amps
X.7	Ground Fault Delay	0.1...250.0	0.5	R/W	Seconds
X.8	Ground Fault A Level	0.00...5.00	2.5	R/W	Amps
X.9	Ground Fault A Delay	0.1...250.0	0.5	R/W	Seconds
X.10	Ground Fault Inh Time ⁽⁴⁾	0.0...250.0	10.0	R/W	Seconds
X.11	Ground Current	0.00...5.00	0.00	R	Amps
X.12	CT Enable	Disable Enable	Disable	R/W	NA
X.13	CT Scaling A	0.10...5.00	1.00	R	NA
X.14	CT Scaling B				
X.15	CT Scaling C				
X.16	Phase Shift A	-12.50...12.50	0.00	R	Degree
X.17	Phase Shift B				
X.18	Phase Shift C				
X.19	Parameter Mgmt	Ready Factory Default	Ready	R/W	NA

- (1) "X" indicates the port number (07, 08, or 09) the 150-SM6 is connected to the SMC-50 controller. This port number is displayed on the HIM screen below the AB brand logo.
- (2) Configure Turns Ratio to the value of the Ground Fault sensor CT Turns Ratio (for example, 825-CBCT=100:1 Set X.5 to 100).
- (3) The sensing range of the module.
- (4) Inhibit Time lets you inhibit (disable) ground fault protection for the time selected during starting.

Parameter Configuration Module

Using the Parameter Configuration Module (150-SM6)

The Cat. No. 150-SM6 parameter configuration module (PCM) provides simple and limited configuration of the SMC-50 controller. You can insert this PCM into any control module option port (7, 8, or 9). Only one PCM is allowed per control module.

Parameters that **are** configured by the PCM and whose values represent the switch settings appear as read-write parameters to other configuration devices. The parameter values set by the PCM are stored in the control module memory. By using the appropriate removal procedure (remove all power to Control Module and Power Module), you can remove the PCM from the control module and retain its parameter settings.

You can configure parameters that **are not** defined and therefore are not configurable by the Cat. No. 150-SM6 PCM through other means (for example, Human Interface Module (HIM), Connected Components Workbench software, or DriveExecutive software), if necessary.

Application considerations for the 150-SM6 PCM are listed below.

- If another configuration tool attempts to configure a parameter setup by an installed 150-SM6, that parameter will revert back to the 150-SM6 configuration. The PCM overrides other configuration tools.
- The 150-SM6 can only configure the onboard control I/O of the Control Module. If additional I/O are added by using a 150-SM4 Digital I/O Option Module, you must configure those I/O with another programming tool.

When using a Cat. No. 150-SM6 PCM to configure the SMC-50 controller, note that the following features, functions, and modes are not configurable:

- Full voltage start
- Torque ramp start
- External brake stop
- Option card I/O configuration (Cat. No. 150-SM... option modules)
- External bypass
- Specialized output relay configuration (for example, network control, DeviceLogix, auxiliary control)
- Specialized operation modes/features
 - Dual ramp, motor winding heater, emergency run
 - Overload select (Class)
 - Adjustment of slow speed set point

TIP If the PCM is removed, another configuration tool (for example, a HIM) can change a parameter that was previously altered by an installed PCM.

Figure 98 - DIP Switch and Rotary Switch Locations

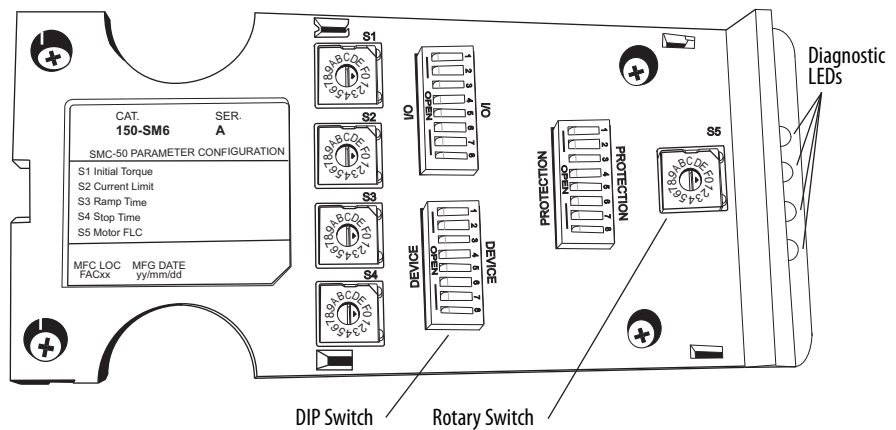

The 150-SM6 PCM contains five rotary switches, S1 through S5, each with designations 0-F and three banks of ON/OFF 8-switch DIP switches.

Table 83 through Table 87 show the resulting values of the position setting functions for each of the five rotary switches and the associated controller parameter numbers. For details on the functions of these parameters, see Chapter 3, 5, 7, and Appendix A.

Table 83 - S1 = Initial Torque Configuration—Controller Parameter 51

Position Setting	Resulting Initial Torque Value (% motor torque)	Position Setting	Resulting Initial Torque Value (% motor torque)
0	10	8	58
1	16	9	64
2	22	A	70 (default)
3	28	B	76
4	34	C	82
5	40	D	88
6	46	E	94
7	52	F	100

Table 84 - S2 = Current Limit Level Configuration—Controller Parameter 53

Position Setting	Resulting Current Limit Value (% FLC)	Position Setting	Resulting Current Limit Value (% FLC)
0	200	8	360 (default)
1	220	9	380
2	240	A	400
3	260	B	420
4	280	C	440
5	300	D	460
6	320	E	480
7	340	F	500

Table 85 - S3 = Ramp Time Configuration—Starting—Controller Parameter 50

Position Setting	Starting Ramp Time (seconds)	Position Setting	Starting Ramp Time (seconds)
0	0.1	8	16
1	2	9	18
2	4	A	20
3	6	B	22
4	8	C	24
5	10 (default)	D	26
6	12	E	28
7	14	F	30

Table 86 - S4 = Stop Time Configuration—Controller Parameter 66

Position Setting	Stop Time (seconds) ⁽¹⁾	Position Setting	Stop Time (seconds) ⁽¹⁾
0	Coast -to-Stop (default)	8	16
1	2	9	18
2	4	A	20
3	6	B	22
4	8	C	24
5	10	D	26
6	12	E	28
7	14	F	30

(1) When the braking STOP MODE is selected (device configuration bank switch #3 and #4), the controller multiplies the selected stop time by ten.

Table 87 - S5 = Motor FLC Configuration—Controller Parameter 78

Position Setting	FLC ⁽¹⁾⁽²⁾ (% of controller's max)	Position Setting	FLC ⁽¹⁾⁽²⁾ (% of controller's max)
0	40 (default)	8	72
1	44	9	76
2	48	A	80
3	52	B	84
4	56	C	88
5	60	D	92
6	64	E	96
7	68	F	100

(1) Because a set of switches do not provide the resolution to enter all possible FLC combinations like a keypad, switch S5 lets you configure the motor's FLC in the SMC-50 controller by using a percent (%) of the controller's rated FLC (for example, 90 A, 110 A, 180 A, etc.)

Example: For a 60 A motor and 90 A controller, % of controllers max. FLC for a 90 A motor = 64% of 90 A (57.6 A), or Switch Position 6.

(2) To determine the S5 switch setting for an inside-the-delta motor configuration, use the following equations:

$$\text{Step 1: } \frac{\text{Motor Nameplate FLC}}{1.73} = X \qquad \text{Step 2: } \frac{X}{\text{SMC-50 Controller Rating}} \times 100 = \text{S5 Switch Setting}$$

$$\text{Step 1: } \frac{100 \text{ A}}{1.73} = 57.8 \text{ A} \qquad \text{Step 2: } \frac{57.8 \text{ A}}{90 \text{ A}} \times 100 = 64\% \qquad \text{Therefore, from the result of 64\%, the S5 switch setting is position 6}$$

- TIP**
- If the calculated value does not match a switch position, use the previous (lower percent) switch setting.
 - You can select the inside-the-delta motor configuration using Motor Connection, Parameter 44, or automatically during a controller tuning process. The tuning process is done during the initial system start after changing any of the tuning parameters and initializing a start or by pressing and holding the SMC-50 controller reset push button for at least 10 seconds with the motor stopped and then initializing a start. If another configuration device is available (for example, a 20-HIM-A6 or PC software such as Connected Components Workbench), changing Force Tuning, Parameter 194, to TRUE or resetting the controller to "Default" also results in tuning to occur.

Table 88 through Table 90 define the functions for the three banks of ON/OFF 8-switch DIP switches. Each of the three banks is defined by a high level, functional name with each switch having a unique function.

Table 88 - ON/OFF 8-Switch DIP Switch Definitions—Device

DEVICE Configuration Bank (0 = Switch OPEN)		Switch Number							
		#1	#2	#3	#4	#5	#6	#7	#8
Starting Mode— Controller Parameter 49	Linear Speed Acceleration (default)	0	0	—	—	—	—	—	—
	Current Limit	0	1	—	—	—	—	—	—
	Soft Start	1	0	—	—	—	—	—	—
	Pump Start	1	1	—	—	—	—	—	—
Stop Mode ^{(1) (2)} — Controller Parameter 65	Linear Speed Deceleration (default)	—	—	0	0	—	—	—	—
	Soft Stop	—	—	0	1	—	—	—	—
	Braking	—	—	1	0	—	—	—	—
	Pump Stop	—	—	1	1	—	—	—	—
Energy Saver⁽³⁾ — Controller Parameter 193	Enable	—	—	—	—	1	—	—	—
	Disable (default)	—	—	—	—	0	—	—	—
Braking Current— Controller Parameter 69	50%	—	—	—	—	—	0	0	0
	100%	—	—	—	—	—	0	0	1
	150%	—	—	—	—	—	0	1	0
	200% (default)	—	—	—	—	—	0	1	1
	250%	—	—	—	—	—	1	0	0
	300%	—	—	—	—	—	1	0	1
	350%	—	—	—	—	—	1	1	0
	400%	—	—	—	—	—	1	1	1

- (1) When the "Stop Mode" is configured as (a) "Linear Speed Decel", (b) "Soft Stop", (c) "Pump Stop", and the "Stop Time" (rotary switch S4) is set to zero, a "Coast" stop will result. A non-zero "Stop Time" value for the three previously listed "Stop Modes" defines the time to stop period which is based on that specific configuration.
- (2) If the "Stop Mode" is configured as "Braking", then the "Stop Time" setting (Rotary Switch S4) is used to select either the "Automatic Zero Speed Detection" method ("Stop Time" is set to zero) or the "Timed Brake" method ("Stop Time" is not set to zero).
- (3) With the Energy Saver switch (#5) set to Enable, the Energy Saver Level, Parameter 193, is automatically configured by the PCM to 0.25.

- TIP**
- With the “Automatic Zero Speed Detection” method, the controller applies the user-selected “Braking Current” defined by the Device Configuration Switch Bank. Switch #6, #7, and #8 senses a motor “Zero Speed” condition and automatically stops the braking process (brake current OFF).
 - With the “Timed Brake” method, the user-selected “Braking Current” is applied for the user-configured “Stop Time” regardless of the motor speed (for example, “Automatic Zero Speed Detection” disabled). The “Timed Brake” method can be used in applications where detecting zero speed is ineffective or when braking the motor to a complete stop results in random overload trips. With this method, braking is applied for a fixed time equal to the "Stop Time" setting (Rotary Switch S4) and multiplied by ten. An ideal "Stop Time" setting can be accomplished by trial and error, but should always allow for some coast time. Setting the "Stop Time" for too long of a time period can result in braking current to be applied to a stopped motor and will likely result in overload trips.

Table 89 - ON/OFF 8-Switch DIP Switch Definitions—Protection

PROTECTION Configuration Bank (0 = Switch OPEN)		Switch Number							
		#1	#2	#3	#4	#5	#6	#7	#8
Preset Protection Level Parameter⁽¹⁾	Enabled (default)	1	—	—	—	—	—	—	—
	Disabled	0	—	—	—	—	—	—	—
Stall Fault Parameter 230	Enabled (default)	—	1	—	—	—	—	—	—
	Disable	—	0	—	—	—	—	—	—
Phase Reversal Fault Parameter 136	Enable	—	—	1	—	—	—	—	—
	Disable (default)	—	—	0	—	—	—	—	—
OL Restart Parameter 264	Enable	—	—	—	1	—	—	—	—
	Disable (default)	—	—	—	0	—	—	—	—
OL Enable Parameter 230	Enabled (default)	—	—	—	—	1	—	—	—
	Disable	—	—	—	—	0	—	—	—
OL Class Parameter 75	10 (default)	—	—	—	—	—	0	0	—
	15	—	—	—	—	—	0	1	—
	20	—	—	—	—	—	1	0	—
	30	—	—	—	—	—	1	1	—

(1) The Preset Production Level DIP switch allows the following Faults to be enabled (1) or disabled (0) as a group.
 Current Imbalance Fault—Parameter Number: 110 [default value: 15]
 Voltage Unbalance Fault—Parameter Number: 106 [default value: 15]
 Line Loss Fault—Parameter Number: NA [default value: no value required - see Chapter 4, Line Loss Protection on page 129]
 Open Gate Fault—Parameter Number: NA [default value: no value required - see Chapter 4, Open SCR Gate Fault & Alarm — Phase A, B, or C on page 130]
 No/Open Load Fault—Parameter Number: NA [default value: no value required - see Chapter 4, Open Load — Fault & Alarm on page 132]
 The PCM configuration setting for each of these Faults follows the currently entered/loaded parameter value for each Fault. This will typically be the default setting unless a 20-HIM-A6 or other configuration tool (for example, PC software or network device) is used to change a parameter setting. The switch setting also overrides the Motor Fault Enable, Parameter 230, and Starter Fault Enable, Parameter 136, function to enable or disable these Faults.
 Note that with the Preset Protection Level switch set to Disable, all Starter and Motor Faults are disabled (as defaults except the Power Quality Fault).

Table 90 - ON/OFF 8-Switch DIP Switch Definitions—Configuration

I/O Configuration ⁽¹⁾ Bank (0 = Switch OPEN)		Switch Number							
		#1	#2	#3	#4	#5	#6	#7	#8
Aux #1 Configuration Parameter 172	Normal (default)	0	0	—	—	—	—	—	—
	Up-to-Speed (UTS)	0	1	—	—	—	—	—	—
	Fault	1	0	—	—	—	—	—	—
	Alarm	1	1	—	—	—	—	—	—
Aux #2 Configuration Parameter 176	Normal	—	—	0	0	—	—	—	—
	UTS [default]	—	—	0	1	—	—	—	—
	Fault	—	—	1	0	—	—	—	—
	Alarm	—	—	1	1	—	—	—	—
Input #1 Parameter 56	Start/Coast (default)	—	—	—	—	0	—	—	—
	Start/Stop Option	—	—	—	—	1	—	—	—
Input #2 Parameter 57	Stop Option (default)	—	—	—	—	—	0	0	—
	Clear Fault	—	—	—	—	—	0	1	—
	Slow Speed	—	—	—	—	—	1	0	—
	Fault	—	—	—	—	—	1	1	—

(1) The I/O Configuration ability of the 150-SM6 is limited to the Control Module's standard I/O.

Notes:

Metering

Overview

While the SMC-50 operates a motor, it is also monitoring several different parameters to provide a full-function metering package.

Viewing Metering Data

To access the metering information using the 20-HIM-A6, use the keypad to follow the procedure below.

1. From the SMC-50 controller standard power-up screen, select **FOLDERS**.
2. Use the right or left arrow until the **Port 00 DEV PARAM** screen is displayed.

TIP Ensure the Advanced Access Level is selected, located at the bottom of the DEV PARAM screen. For additional configuration details, see [Parameter Access Level Modification Using the HIM on page 158](#).

3. From the **Port 00 DEV PARAM** screen, select File-Group, then press the ENTER key (number 5 on the keypad). The **Port 00 Param File-Group** screen appears.
4. Use the up or down Arrow key to select File Monitoring. The Port 00 Param File-Group File Monitoring screen appears with seven GROUP metering selections (Metering Basics, Metering Volts, Metering Current, Metering Power, Start Stats. Monitoring, Power Quality).

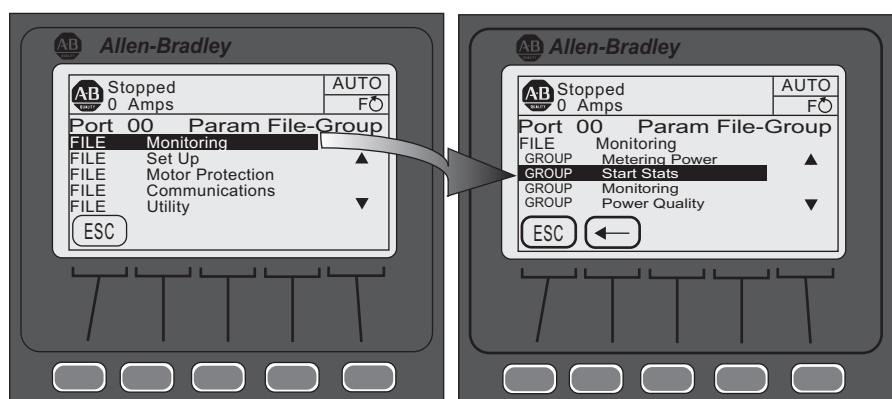

5. Use the up or down arrow key to select the desired GROUP, then press the ENTER key (number 5 on the keypad).
6. Select the desired parameter from the previous group selected, then press the ENTER key to monitor the metering parameter.

TIP With the exception of the Meter Reset, Parameter 16, the metering parameters contained in the Monitoring File-Group are Read (R) only. See [Metering System on page 29](#) and [Metering Parameters on page 204](#) for a detailed list of metering parameters.

Resetting Metering Parameters

Meter Reset, Parameter 16, is used to clear (reset to 0) the contents of metering parameters Elapsed Time, Energy, Time to PM (Preventive Maintenance), and Starts to PM. To clear the contents of any one of these parameters, configure Meter Reset to the specific parameter you wish to clear.

EXAMPLE To clear (reset to 0) the Elapsed Time, configure Meter Reset to Elapsed Time. The controller will then clear the Elapsed Time and the value of Meter Reset will return to Ready 0.

To access Meter Reset using the 20-HIM-A6, perform steps [1](#) through [4](#), [Viewing Metering Data](#).

1. From Step [4](#), select the **Metering Basic Group**, then press ENTER (number 5 on the keypad).
2. Use the down arrow on the keypad to select/highlight **Meter Reset**.
3. With Meter Reset highlighted, press the ENTER key (number 5 on the keypad) or the ENTER soft key.
4. Press the EDIT soft key.
5. Use the up or down arrow to select the desired parameter (Elapsed Time, Energy, Time to PM, or Starts to PM) to be reset, then press the soft ENTER soft key. The selected parameter is reset to zero with the exception of the Starts to PM.

TIP When the ENTER key is pressed and Starts to PM is selected, its contents is set to the value contained in PM Starts, Parameter 127.

Metering Parameters

Current

The SMC-50 controller calculates true RMS current based on Current Transformer (CT) feedback for all three phases. It also calculates an average value of the three phase currents. During Braking and Slow Speed operation, the calculated current is estimated based on time and current settings. This parameter reports the three-phase motor current measurements. These measurements are always line current, regardless of the type of connection. The accuracy of the current calculation is $\pm 5\%$ of the true RMS current.

Table 91 - Metering Parameters Associated with Current

Parameter Number	Name/Description	Min/Max Value	Default Value	Access	Units
5	Current Average	0...15,000	0	R	Amps
6	Current Phase A				
7	Current Phase B				
8	Current Phase C				

Voltage

Line-to-Line and Line-to-Neutral RMS voltage is calculated for all three phases with the average of the three voltages also provided. The data is provided whenever 3-phase power is applied.

The accuracy of the voltage calculations is $\pm 2\%$ of the true RMS voltage.

Table 92 - Metering Parameters Associated with Voltage

Parameter Number	Name/Description	Min/Max Value	Default Value	Access	Units
1	Voltage P-P Average	[0]...700	[0]...700	R	Volts
2	Volts Phase A-B				
3	Volts Phase B-C				
4	Volts Phase C-A				
265	Voltage P-N Average	[0]...450	[0]...450	R	Volts
266	Volts Phase A-N				
267	Volts Phase B-N				
268	Volts Phase C-N				

Torque

The SMC-50 controller calculates true electromechanical torque based on the existing motor voltage and current feedback data.

- TIP**
- During Braking and Slow Speed operations, Torque reads 0.
 - For the Torque parameter to display correctly, the motor value for Rated Torque, Parameter 47, and Rated Speed, Parameter 48, must be correctly configured.

The accuracy of the torque calculations is $\pm 10\%$ of the true electromechanical torque.

Table 93 - Metering Parameters Associated with Torque

Parameter Number	Name/Description	Min/Max Value	Default Value	Access	Units
9	Torque	-50...3000	0	R	%

Power

Real, Reactive, and Apparent power calculations (along with demand and maximum demand) are made on each line power phase along with a total for all three phases.

The Energy parameters can be cleared using the Meter Reset parameter. See [Resetting Metering Parameters on page 204](#) for further details.

- TIP** For Reactive Energy, Parameter 278 and 279, the system will keep a:
- positive energy, which only integrates power when it is positive,
 - negative energy, which only integrates power when it is negative, and
 - net energy, which always integrates.

The demand numbers are calculated as follows:

- Energy is calculated over a period of time defined by "Demand Period", Parameter 290.
- The previous "n" period values are averaged and the result is written to the Demand, Parameter 272, 281 and 288, which is used in calculating the Max Demand values. This averaging uses a rolling window algorithm where the previous "n" periods are averaged.

Table 94 - Metering Parameters Associated with Power

Parameter Number	Name/Description	Min/Max Value	Default Value	Access	Units
269	Real Power A	±1000.000	0.000	R	MW
270	Real Power B				
271	Real Power C				
10	Real Power				
11	Real Energy	±1000.000	0.000	R	MWH
272	Real Demand	±1000.000	0.000	R	MW
273	Max Real Demand				
274	Reactive Power A	±1000.000	0.000	R	MVAR
275	Reactive Power B				
276	Reactive Power C				
277	Reactive Power				
278	Reactive Energy C	1000.000	0.000	R	MVRH
279	Reactive Energy P				
280	Reactive Energy	±1000.000	0.000	R	MVRH
281	Reactive Demand	±1000.000	0.000	R	MVAR
282	Max. Reactive Dmd				
283	Apparent Power A	±1000.000	0.000	R	MVA
284	Apparent Power B				
285	Apparent Power C				
286	Apparent Power				MVAH
287	Apparent Energy				
288	Apparent Demand				
289	Max. Apparent Demand				
290	Demand Period	1...255	1	R/W	min
291	Number of Periods	1...15	1	R/W	—

Power Factor

Power Factor is calculated for each phase along with a total power factor value. The power factor calculation does not apply during Slow Speed and Braking operations.

Table 95 - Metering Parameters Associated with Power Factor

Parameter Number	Name/Description	Min/Max Value	Default Value	Access	Units
292	Power Factor A	-1.00...1.00	0.00	R	NA
293	Power Factor B				
294	Power Factor C				
17	Power Factor				

Energy Savings

The energy saver function only applies during light motor load situations, at which time the SMC-50 controller reduces current to the motor and thereby saves energy.

When in energy saver operation, the Energy Savings status bit is set. In addition, Energy Savings, Parameter 15, indicates the percentage energy savings.

Parameter 17 - [Power Factor] should be monitored and recorded when the motor is running at no/light load and at full/heavy load. The power factor value where the controller enters Energy Saver mode is determined by setting **Parameter 193 - [Energy Saver]** to a value between the no/light load and full/heavy load recorded values.

Table 96 - Energy Saver Mode Parameter List

Parameter Number	Parameter Name	Min/Max Value	Default Value	Access	Units
15	Energy Savings	0...100	0...100	R	%
17	Power Factor	-1.00...1.00	-1.00...1.00	R	—
193	Energy Saver	0.00-1.00	0.00	R/W	—

TIP Set Parameter 193 = 0 to disable Energy Saver mode.

Elapsed Time

The SMC-50 controller keeps a log of the total accumulated hours the controlled motor has been running via the Elapsed Time metering parameter. The Elapsed Time meter value is updated every 10 minutes and stored at power down (accurate to 1/6 of an hour). The Elapsed Time meter accumulates to 50,000 hours of operation and can be reset to zero via the Meter Reset parameter (see [Resetting Metering Parameters on page 204](#)).

Elapsed Time 2 is similar to Elapsed Time. Elapsed Time 2 differs in that you cannot reset it and will count up to 50,000 hours and then hold that value (it will not roll over).

Table 97 - Metering Parameters Associated with Elapsed Time

Parameter Number	Name/Description	Min/Max Value	Default Value	Access	Units
12	Elapsed Time	0.0...50000.0	0.0	R/W	Hours
13	Elapsed Time 2			R	

Running Time

The Running Time meter parameter logs the amount of time the motor has been operating. The timer resets to zero and begins counting as each start command is received.

TIP When the SMC-50 controller is stopped, the parameter displays the length of time the motor was previously operating.

Table 98 - Metering Parameters Associated with Running Time

Parameter Number	Name/Description	Min/Max Value	Default Value	Access	Units
14	Running Time	0.0...5000.0	0.0	R	Hours

Motor Speed

The Motor Speed meter parameter is only valid when using the Linear Speed Starting or Linear Speed Stopping modes. It provides the estimated motor speed during either the starting or stopping maneuver. When the SMC-50 controller is not in these modes, the Motor Speed meter parameter reads zero except when the unit is at speed. In this case, the parameter displays 100%.

Table 99 - Metering Parameters Associated with Motor Speed

Parameter Number	Name/Description	Min/Max Value	Default Value	Access	Units
34	Motor Speed	0...100	0.0	R	%

Actual Start Time

The SMC-50 controller logs the start time of the last five motor starts and stores that information in Parameters 24 through 28. The start time data is stored in a first-in, first-out method so the record of the last five starts is always maintained.

Table 100 - Metering Parameters Associated with Actual Start Time

Parameter Number	Name/Description	Min/Max Value	Default Value	Access	Units
24	Start Time 1	0...1000	0	R	Seconds
25	Start Time 2				
26	Start Time 3				
27	Start Time 4				
28	Start Time 5				

Peak Start Current

The SMC-50 controller logs the peak average RMS current during each start and stores that information in Parameters 29 through 33. The Peak Start Current data is stored in a first-in, first-out method so the record of the last five starts is always maintained.

Table 101 - Metering Parameters Associated with Peak Start Current

Parameter Number	Name/Description	Min/Max Value	Default Value	Access	Units
29	Peak Current 1	0...15,000	0	R	Amps
30	Peak Current 2				
31	Peak Current 3				
32	Peak Current 4				
33	Peak Current 5				

Total Starts

The SMC-50 controller maintains a Total Start counter which is incremented each time the controller is started. As shipped, the counter value is zero. You cannot reset it.

TIP The Total Starts counter is not incremented if the controller faults on a pre-start fault. It is incremented once SCR gating begins.

Table 102 - Metering Parameters Associated with Total Starts

Parameter Number	Name/Description	Min/Max Value	Default Value	Access	Units
23	Total Starts	0...30,000	0.0	R	NA

Total Harmonic Distortion (THD)

The SMC-50 controller provides the IEEE calculated THD value for the three Line Voltages (Line-to-Neutral) and the three Motor Phase Currents (current through SMC-50 controller Power Pole⁽¹⁾). In addition, the average THD is calculated for both Line Voltage and Phase Current.

The controller algorithm uses a round-robin approach to gather the six signals by sampling one signal and then calculating the THD value for that signal. In other words, each power cycle current and voltage THD are calculated for a phase, then for the next phase and so on.

TIP When the motor is not running, the Current-Based THD values read 0.

Table 103 - Metering Parameters Associated with THD

Parameter Number	Name/Description	Min/Max Value	Default Value	Access	Units
35	THD V _a	0.0...1000.0	0.0	R	%
36	THD V _b				
37	THD V _c				
38	THD V _{ave}				
39	THD I _a	0.0...1000.0	0.0	R	%
40	THD I _b				
41	THD I _c				
42	THD I _{ave}				

(1) When in external bypass running mode/configuration, you can use an external CT (825-MCM) and a 150-SM2 Option Module to read current-based (THD I_x) values.

Line Frequency

The SMC-50 controller measures and displays the system 3-phase AC Line Frequency. Upon power up, the Line Frequency parameter displays zero until a valid AC Line Frequency is measured. When three-phase power is removed from the SMC-50 controller, the parameter maintains the value of the previous frequency reading.

Table 104 - Metering Parameters Associated with Line Frequency

Parameter Number	Name/Description	Min/Max Value	Default Value	Access	Units
224	Line Frequency	0...100	0	R	Hz

Current Imbalance

The SMC-50 controller provides a calculated Current Imbalance value. The Current Imbalance calculation is equal to the largest deviation of the three RMS phase current signals from the average RMS phase current, divided by the average. Note that the SMC-50 controller Power Pole Current is used for the Current Imbalance calculation.

Table 105 - Metering Parameters Associated with Current Imbalance

Parameter Number	Name/Description	Min/Max Value	Default Value	Access	Units
295	Current Imbalance	0...100	0	R	%

Voltage Unbalance

The SMC-50 controller provides a calculated Voltage Unbalance value. The Voltage Unbalance calculation is equal to the largest deviation of the three RMS phase voltage signals from the average RMS phase voltage divided by the average. Note that the phase-to-neutral voltage is used in the calculation for voltage unbalance.

Table 106 - Metering Parameters Associated with Voltage Unbalance

Parameter Number	Name/Description	Min/Max Value	Default Value	Access	Units
296	Voltage Unbalance	0...100	0	R	%

Optional HIM Operation

Overview

The SMC-50 controller offers a variety of unique control options that provide enhanced motor starting and stopping capabilities.

HIM Control Buttons

The control buttons available with the Bulletin 20-HIM-A6 LCD modules are compatible with the control options on the controller. [Table 107](#), [Table 108](#) and [Table 109](#) detail the functionality of each control button. For additional details on using the 20-HIM-A6, see the user manual, publication [20HIM-UM001](#).

IMPORTANT You must enable the logic mask port before you initiate control commands except for Stop, which always initiate a Coast-to-Stop command. See [Control Enable](#) for instructions.

The control terminals must be wired according to [Figure 33](#) or [Figure 44](#).



ATTENTION: The Bulletin 20-HIM-A6 LCD module's stop push button is not intended to be used as an emergency stop. See applicable standards for emergency stop requirements.

Table 107 - 20-HIM-A6 Control Button Functionality, Standard Control







Option	Action	Operation When Pressed
Soft Stop Current Limit Full Voltage Linear Speed		The green start button begins motor acceleration to full speed.
		The red stop button provides a coast stop, and/or reset a fault.
		This button brings up the Control Screen to enable the stop option maneuver. See the HIM Control Screen section.
Preset Slow Speed		The green start button, when pressed, begins motor acceleration to full speed.
		The red stop button, when pressed, provides a coast stop and/or reset a fault.
		This button displays the Control screen. * Slow Speed cannot be operated via the HIM.

Table 108 - 20-HIM-A6 Control Button Functionality, Pump Control













Option	Action	Operation When Pressed
Pump Control		The green start button begins motor acceleration to full speed.
		The red stop button provides a coast stop, and/or reset a fault.
		Displays the Control Screen with the Jog button. The jog button initiates a pump stop maneuver.

Table 109 - 20-HIM-A6 Control Button Functionality, Braking Control

Option	Action	Operation When Pressed
Braking Control		
Smart Motor Braking		The green start button begins motor acceleration to full speed.
		The red stop button provides a coast stop, and/or reset a fault.
		Displays the Control Screen with the Jog button. The jog button initiates a brake stop.
Accu-Stop ⁽¹⁾		The green start button begins motor acceleration to full speed.
		The red stop button provides a coast stop, and/or reset a fault.
		Displays the Control Screen with the Jog button. The jog button initiates braking to slow speed operation. The controller will maintain slow speed operation as long as the jog button is pressed.
Slow Speed with Braking		The green start button begins motor acceleration to full speed.
		The red stop button provides a coast stop, and/or resets a fault.
		Displays the Control Screen with the Jog button. The jog button initiates a brake stop from slow speed. * Slow Speed cannot be operated via the HIM.

(1) Accu-Stop is not included as a parameter/function as the SMC-Flex was. However, Accu-Stop is accomplished with the Stop option and the Slow Speed with Braking.

HIM Control Screen

The HIM Control Screen is typically used to directly control a drive. Press the



(controls) key to display the Control Screen.

IMPORTANT To navigate from the Control Screen to another HIM menu screen, you must press the ESC soft key. This deactivates the Control Screen and displays the previous screen.

Figure 99 - HIM Control Screen

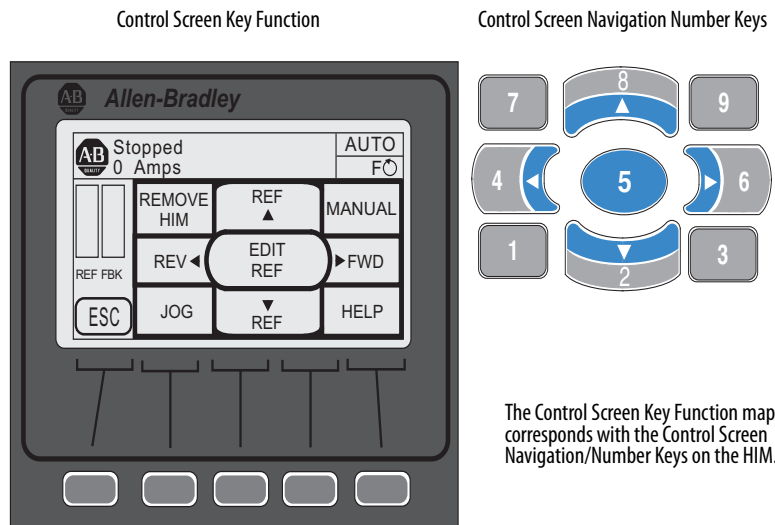

The Control Screen Key Function map corresponds with the Control Screen Navigation/Number Keys on the HIM.

Table 110 - Control Screen Soft Key Functionality

Label	Name	Function
ESC	Escape	Reverts back to the previous screen.

Table 111 - Control Screen Navigation/Number Keys

Label	Name	Function
JOG		Stop Option for SMC-50 controller
REF ▼		NA
HELP		Displays Rockwell Automation Drive's Technical Support direct phone number, website address, and email address. ⁽¹⁾
REV ◀		NA
EDIT REF		NA
FWD ▶		NA
REMOVE HIM		Allows HIM removal without causing a fault if the HIM is not the last controlling device. The REMOVE HIM label is not available when the HIM has a manual control of the host SMC-50 controller. In this case, a fault occurs if the HIM is removed.
REF ▲		NA
MANUAL		NA

(1) Technical Support for drives does not apply to the SMC-50 controller. You can contact Technical Support for the SMC-50 controller at: 440-646-5800 (option 2 and option 4) or raitechsupport@ra.rockwell.com.

CopyCat Function of the 20-HIM-A6

The SMC-50 controller supports the CopyCat function of the 20-HIM-A6. For details on using the CopyCat function, see the 20-HIM-A6 user manual, [20HIM-UM001](#).

Communications

Overview

The SMC-50 controller provides advanced communications capabilities that allow you to start and stop it from multiple sources and provide diagnostic information through the use of communication interfaces. The SMC-50 controller uses DPI as an internal method of communication bus; therefore, all standard DPI communication interfaces that are used by other devices (for example, PowerFlex® Drives) can be used in the SMC-50 controller. ScanPort™ devices are not supported by the SMC-50 controller.

Standard DPI communications cards are available for various protocols, including DeviceNet, ControlNet, ModBus™, and Profibus® DP. Other modules may be available in the future. For specific programming examples, configuration, or programming information, see the user manual for the communication module being used. [Table 112](#) shows a list of available modules.

Table 112 - Communication Card Selection by Protocol Type

Protocol Type	Cat. No.	User Manual
DeviceNet	20-COMM-D	20COMM-UM002
ControlNet	20-COMM-C	20COMM-UM003
Profibus®	20-COMM-P	20COMM-UM006
RS-485	20-COMM-S	20COMM-UM005
InterBus	20-COMM-I	20COMM-UM007
EtherNet/IP	20-COMM-E	20COMM-UM010
Dual Port EtherNet/IP	20-COMM-ER	20COMM-UM015
RS485 HVAC	20-COMM-H	20COMM-UM009
ControlNet (Fiber)	20-COMM-Q	20COMM-UM003
CANopen	20-COMM-K	20COMM-UM012

Communication Ports

The SMC-50 controller supports four DPI ports for communication. Port 1 is for the front-mounted (bezel) Human Interface Module (HIM). Ports 2 and 3 are supported through the serial connection on the top of the device and are typically used to interface with a door mounted HIM or a PC. Port 2 is the default connection with port 3 available by installing a splitter on port 2. DPI Port 4 is supported by connecting one of the communication cards listed in [Table 112](#) to the internal DPI communication card connection (SMC-50 controller hardware controller port 9).

HIM Keypad and Displays

The SMC-50 controller can be programmed with the optional Bulletin 20-HIM-A6 LCD display. Parameters are organized in a multi-level menu structure and are divided into programming groups.

Connecting the HIM to the Controller

[Figure 100](#) shows how to connect a HIM and DPI device to the SMC-50 controller. [Table 113](#) provides a description of each port.

TIP The SMC-50 controller only supports the use of DPI communication modules and DPI 20-HIM-A6 Modules.

See the control wiring diagram that enables start-stop control from a HIM.

Figure 100 - SMC-50 controller with a HIM

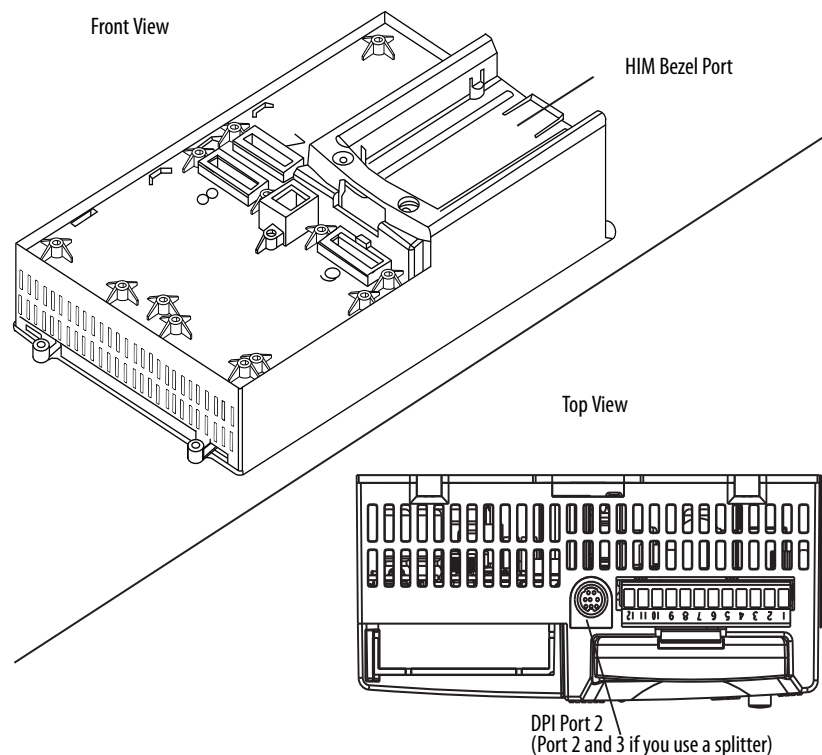

Table 113 - Description of Ports

DPI Port Number	Source
1	Front-Mounted HIM (HIM Bezel)
2	Remote DPI (top of SMC-50 controller)
3	Remote DPI (top of SMC-50 controller with splitter)
4 ⁽¹⁾	20-COMM-x Module

(1) When using a 20-COMM-x network communication module, it must physically be located in control module hardware port 9. However, its DPI Port Number assignment is 4. The cable connection for the DPI Port 4 is located below the HIM bezel (see [Figure 100](#)).

Control Enable

Logic Mask, Parameter 148, lets you configure whether a communication device (HIM or network connection) can perform motor control commands such as starting. Each communication port (1 through 4) can be enabled (bit=1) or disabled (bit=0) as required. When a given device is enabled through the logic mask that device is allowed to execute control commands. In addition, disconnecting any device with the logic mask enabled will result in an Exp Removed (X026)⁽¹⁾ communication fault. You can disconnect a device that is disabled through the logic mask without causing a fault⁽²⁾



IMPORTANT Stop commands override all start commands and can be initiated from the hardwired inputs or any DPI port regardless of the logic mask.

Logic Mask Enable/Disable using a HIM

To enable motor control using a connected HIM, follow the procedure below with the connected HIM's programming keys.

The Bulletin 20-HIM-A6 provides start and stop control of the SMC-50 controller. However, the Logic Mask factory default settings disable control commands other than Stop through the controller's DPI ports 1, 2, 3, or 4.

To enable motor control from either of the four ports using a connected 20-HIM-A6, the following steps must be performed from the SMC-50 controller standard power-up screen.

1. Press the  key. Use the right or left arrow key on the keypad to display the <00> DEV PARAM folder screen.
2. Select/highlight the File-Group.
3. Press the  (enter) key. The Port 00 Param File-Group screen appears.



TIP Ensure the Advanced Access Level is selected, located at the bottom of the DEV PARAM screen. For additional configuration details, see [Parameter Access Level Modification Using the HIM on page 158](#).

(1) When a given device is disabled through the logic mask that device cannot execute control commands, but can still be used for configuration and monitoring. X = DPI port number of the device causing the Fault.

(2) If a 20-HIM-A6 is enabled for control via the Logic Mask, it can still be removed using the HIM control screen. See [Chapter 8](#).

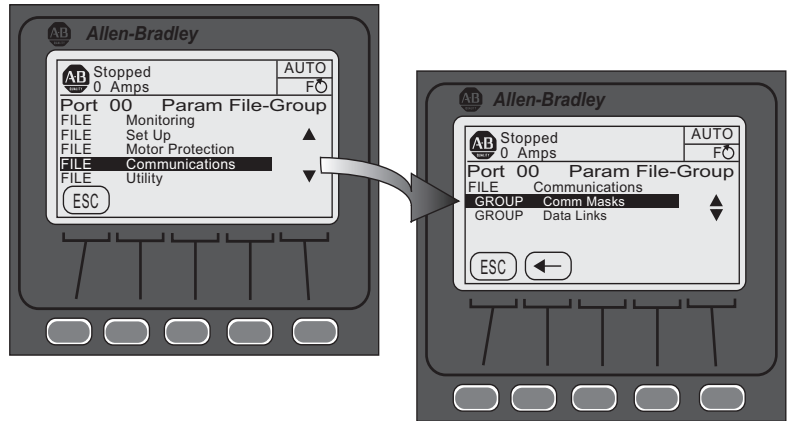
- Press the  to select FILE Communications, then press . The GROUP Comm Masks and Data Links screen appears.



- With Comm Mask selected/highlighted, press the  key. The GROUP Comm Masks screen appears with the associated Logic Mask Action selected.
- Select/highlight Logic Mask, then press the  key. The Edit Logic Mask screen with bit field appears.

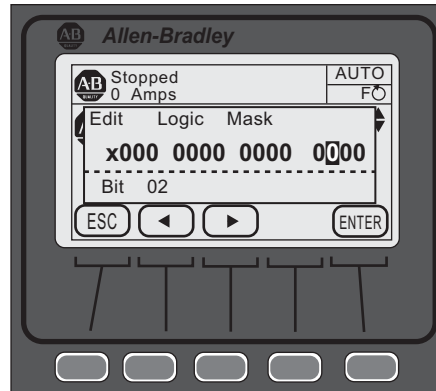

- Press the EDIT key to modify the settings, then use the left or right arrow to select the desired bit, 1 through 4, then press the  key.



To enable motor control, press  or press  to disable motor control from the selected DPI port, then press EDIT.

Table 114 - Logic Mask and Logic Mask Active Parameter Specifications

Parameter		Bit Number	DPI Assignment	Access	Units [default]
Number	Name				
148	Logic Mask	0 - NA	Port 0 - NA	R/W	Bit = 0 [disabled] Bit = 1 enabled
		1	Port 1		
149	Logic Mask Act	2	Port 2	R	Bit = 0 [disabled] Bit = 1 enabled [Follows Logic Mask]
		3	Port 3		
		4	Port 4		
		5 - 15 NA	Port 5 - 15 NA		

- IMPORTANT**
- The Logic Mask must be set to 0 or the "REMOVE HIM" key is depressed via the HIM controller screen (see [Chapter 8](#)) before you disconnect the HIM from the SMC-50 controller. If not, the unit will fault on a "Exp. Removed".
 - The Logic Mask Active, Parameter 149, is a read-only parameter that shows the logic mask actually in use at any given time. It typically follows the Logic Mask, Parameter 148, except in some application environments where network communication is in use.

Loss of Communication with DPI Device

An "Exp. Removed" fault indicates that a device was improperly removed. There is a Fault code determined by port number.

DPI provides a separate Exp. fault for each port. This fault can be generated directly by the peripheral and is separate from the Exp. Removed fault (device specific).

Default Input/Output Communication Configuration

The default configuration for I/O communication is 4 bytes in and 4 bytes out (TX = 4 bytes, RX = 4 bytes). The total size may vary when used with a communication card. The default configuration is arranged according to the following table.

Table 115 - Default Configuration

Word	Produced Data (Status)	Consumed Data (Control)
0	Logic Status	Logic Command
1	Feedback ⁽¹⁾	Reference ⁽²⁾

(1) The feedback word is always Ave Current.

(2) The reference word is not used with the SMC-50 controller, however the space must be reserved.

TIP The total data size produced or consumed may vary, depending on the communication card being used. For more information, see the user manual of the specific communication card being used with the SMC-50 controller.

Variable Input/Output Configuration

The SMC-50 controller supports 32-bit Data Links. Therefore, you can configure the device to return additional information. The I/O message size depends on how many DataLinks are enabled. The following table summarizes the I/O data sizes.

Table 116 - I/O Data Sizes

Rx Size	Tx Size	Logic Status/Command (16-bit)	Reference/FeedBack (16-bit)	DataLinks			
				A	B	C	D
4	4	x	x				
12	12	x	x	x			
20	20	x	x	x	x		
28	28	x	x	x	x	x	
36	36	x	x	x	x	x	x

To configure DataLinks, see [Configuring DataLink™ on page 222](#).

SMC-50 Controller—Bit Identification

Product Functional (Logic) Status, Parameter 43, is used to provide SMC-50 controller functional (logic) status to communication devices. [Table 117](#) details Parameter 43, which is a read-only parameter.

Table 117 - Logic Status

Bit Number	Status/Function	Description	
		1	0
0	Enabled/Ready	Control Power Applied	Control Power NOT applied
1	Running	Power applied to motor (gating SCRs or bypass closed)	Power NOT applied to motor
2	Phasing	ABC phasing	CBA phasing
3	Phasing Active	Three-phase is valid	No valid three-phase detected
4	Starting (Accel)	Performing a start maneuver (slow speed not included)	Not performing a start maneuver
5	Stopping (Decel)	Performing a stop maneuver (coast to stop not included)	Not performing a stop maneuver
6	Alarm	Alarm present	No alarm present
7	Fault	Fault condition exists and has not been cleared	No fault condition
8	At Speed	Full voltage applied (bypass or full SCR conduction)	No full voltage applied
9	Start/Isolation	Start/Isolation contactor enabled	Start/Isolation contactor disabled
10	Bypass	Bypass contactor enabled	Bypass contactor disabled
11	Ready	Ready to Run	Control Inhibit Active (do not run)
12-13	Reserved	Always 0	
14	Input #1	Control Module Input #1 Status	
15	Input #2	Control Module Input #2 Status	

Table 118 - Logic Command Word (Control)

Bit Number	Control	Description	
		1	0
0	Stop	Coast/Inhibit	No action
1	Start	Start	No action
2	Stop Option	Stop/Maneuver	No action
3	Clear Fault	Clear fault	No action
4	Slow Speed 1	Run at slow speed 1	No action
5	Emergency Run	Enable emergency run mode	Disable emergency run mode
6	Motor Winding Heater	Enable motor winding heater	Disable motor winding heater
7	Slow Speed 2	Run at slow speed 2	No action
8-10	Reserved	These bits must always be set to 0	
11	Aux Enable	Use the Network #1 - #4 bits	Ignore the Network #1 - #4 bits
12	Network #1	Closes any output configured for Network #1	Opens any output configured for Network #1
13	Network #2	Closes any output configured for Network #2	Opens any output configured for Network #2
14	Network #3	Closes any output configured for Network #3	Opens any output configured for Network #3
15	Network #4	Closes any output configured for Network #4	Opens any output configured for Network #4

Reference/Feedback

The SMC-50 controller does not offer the analog **Reference** feature. The analog **Feedback** feature is supported and provides Current Average, Parameter 5, automatically as the feedback word.

Parameter Information

A complete listing of the SMC-50 parameters is located in [Appendix B](#).

Scale Factors for PLC Communication

The parameter values stored and produced by the SMC-50 through communication are unscaled numbers. When reading or writing values from a PLC image table, it is important to apply the proper scaling factor, which is based on the number of decimal places.

Read Example

Power Factor, Parameter 17—The stored value is 85. Because this value has two decimal places, the value should be divided by 100. The correctly read value is 0.85.

Write Example

Motor FLC, Parameter 78—The example value, which is to be written to the SMC-50 controller, is 75 A. Because this value has one decimal place, the value should be multiplied by 10. The correctly written value is 750.

Display Text Unit Equivalents

Some parameters have text descriptions when viewed from a HIM or through a communication software program such as RSNetworx™. When receiving or sending information from a PLC each text description has a numerical equivalent. The table below shows an example of Meter Reset, Parameter 16, and the appropriate relationship between the text descriptor and the equivalent value. This relationship is identical for other similar parameters located in Appendix B.

Table 119 - Meter Reset Parameter Example

Text Description	Numerical Equivalent
Ready	0
Elapsed Time	1
Energy	2
Time to PM	3
Starts to PM	4

Configuring DataLink™

DataLink is supported in the SMC-50 controller. DataLink is a mechanism that most drives use to transfer data to and from the controller without using an explicit message. The SMC-50 controller supports a 32-bit DataLink, allowing you to configure the device to return up to eight additional pieces of information without the need for an explicit message.

Criteria for Using DataLink

- Each set of DataLink parameters in an SMC-50 can be used by only one adapter. If more than one adapter is connected, multiple adapters must not try to use the same DataLink.
- Parameter settings (contents) in the SMC-50 controller determine the data passed through the DataLink mechanism.
- When DataLink is used to change a value in the SMC-50 controller, the value is not written to the Non-Volatile Storage (NVS). However, if the SMC-50 controller is powered down, the current value is written to NVS.

To configure DataLink, you must use Parameters 153...168 of the SMC-50 controller. See [Table 120](#) for a detailed listing of these parameters. For additional information about DataLink, see the communication interface's user manual.

Table 120 - Parameter 153 - 168 DataLinks Detail

Parameter Number	Description	Min/Max [Default]	Access	Units			
153	Data In	[0]-Max Parameter Number ⁽¹⁾	R/W	—			
154				A2	—		
155				B1	—		
156				B2	—		
157				C1	—		
158				C2	—		
159				D1	—		
160				D2	—		
161	Data Out			[0]-Max Parameter Number ⁽¹⁾	R/W	—	
162						A2	—
163						B1	—
164						B2	—
165						C1	—
166						C2	—
167						D1	—
168						D2	—

(1) The data transferred via the DataLink function is the setting (content(s)) of the parameter number as entered by you here.

Updating Firmware

You can obtain the latest version of firmware and instructions for the SMC-50 controller can be obtained from <http://ab.rockwellautomation.com/Motor-Control/LV-Soft-Starters/SMC-50#resources>.

Notes:

Diagnosics

Overview

This chapter describes the fault diagnostics of the SMC-50 controller and the conditions that cause various faults to occur.

Protection Programming

Many of the protective features available with the SMC-50 controller can be enabled and adjusted through the programming parameters provided. For further details on programming, see [Motor Protection on page 179](#).

Diagnostic LEDs

The SMC-50 controller multi-color Diagnostic LED Status Indicator and HOLD TO TEST, PUSH TO RESET button are located below the HIM bezel port. The Status LED indicates the status and fault conditions of the SMC-50 controller.

Table 121 - Corresponding LED Color and Fault Conditions

Status LED Color	Device Mode	SMC-50 Controller Status
Green	Running	Running without an alarm
Green/Amber	Running	Running with an alarm
Green Flashing	Ready	Ready (no inhibit and no fault) without an alarm
Amber/Flashing	Ready	Ready (no inhibit and no fault) with tuning enabled on the next start
Amber	Ready	Ready with alarm (no tuning enabled)
Red/Amber	Inhibit	Inhibited; cannot start due to a Stop command
Red	Faulted	A non-resettable fault has occurred
Red/Flashing	Faulted	A resettable fault has occurred
Red/Green	Download	Firmware is being downloaded

The HOLD TO TEST, PUSH TO RESET button lets you reset an alarm/fault, test for a fault condition, and initiate the tuning mode.

Table 122 - Function Initiation of the HOLD TO TEST, PUSH TO RESET Button

Function	Time Required to Press Button
Fault Reset	Momentary (less than 2 seconds)
Test Fault	Greater than 3 seconds, but less than 10 seconds
Initiate Tuning Mode	Greater than 10 seconds (motor must be stopped)

Using the Controller Status LED and Parameter Configuration Module (150-SM6) LEDs

When you install a 150-SM6 module in one of the three control module ports (7, 8, or 9) of the SMC-50 controller, it provides additional LED diagnostic information beyond that of the Status LED.

The 150-SM6 has four diagnostic/status LEDs to display an LED code for each fault/alarm. When the SMC-50 controller's Status LED indicates the control module has faulted, the 150-SM6 displays a specific fault code. If the unit is not faulted but in an alarm condition, the 150-SM6 displays the alarm code. If the unit is neither faulted or in an alarm condition, all 150-SM6 LEDs do not illuminate.

The 150-SM6 > (<) LED indicates whether the fault/alarm is an SMC-50 controller device fault/alarm or a motor fault/alarm. The on/off status of the other three LEDs indicate the actual fault/alarm codes.

Depending on which SMC-50 controller port the 150-SM6 is installed into, the position of the LEDs (for example, >, III, II, and I versus I, II, III, and <) change. [Table 123](#) displays the LED order when the 150-SM6 is installed in port 7. When the 150-SM6 is installed in port 8 or 9, the order is reversed, but the LED diagnostic code is the same.

Table 123 - LED Order When 150-SM6 is Installed in Port 7 of the SMC-50 controller

LED Error Code	LED On/Off State			
	>	III	II	I
0		Off	Off	Off
1		Off	Off	On
2		Off	On	Off
3	Red = SMC	Off	On	On
4	Yellow = Motor	On	Off	Off
5	Off = No Fault or Alarm	On	Off	On
6		On	On	Off
7		On	On	On

The displayed LED error code is either a fault or an alarm code depending on the cause. For example, if the LED code is 1, Line Loss A is either a fault or an alarm. If you want a more detailed display of the error code source, a human interface module (HIM) or configuration software is recommended.

[Table 124](#) provides a list of faults with LED fault/alarm codes for the 150-SM6 Parameter Configuration Module.

Table 124 - LED Error Code with Respective Fault/Alarm Source

LED Error Code	Fault/Alarm Source	Referenced HIM/ Configuration Software Code ⁽¹⁾	LED Error Code	Fault/Alarm Source	Referenced HIM/ Configuration Software Code ⁽¹⁾		
Red = SMC							
1	Line Loss	A	1	5	HAL ID	33	
		B	2		NVS Error	34	
		C	3		V24 Recovery	35	
	Shorted SCR	A	4		V24 Loss	36	
		B	5		V Control Loss	37	
		C	6		RTC Battery Low	69	
2	Open Gate	A	7	6	System Faults	100-199	
		B	8		Terminal Block Input	1	38
		C	9			2	39
3	SCR Overtemp	10	3	40			
	Pwr Pole PTC	60	4	41			
4	CT Loss	A	30	7	Test Fault	62	
		B	31		Open Bypass	A	11
		C	32			B	12
Yellow = Motor							
2	No Load		14	4	Overload	21	
	Open Load	A	15	5	Stall	24	
		B	16	6	Phase Reversal	25	
		C	17	7	Current Imbalance	42	
3	Volt Imbalance	18					

(1) The Fault/Alarm code, available from a HIM or configuration software, provides more detailed information concerning the source of the fault/ alarm. Fault and Alarm codes for the same event (for example, Line Loss) are the same.

Fault Display (20-HIM-A6)

When you use the SMC-50 controller with a 20-HIM-A6, the HIM displays the fault information.

Figure 101 - Fault Display

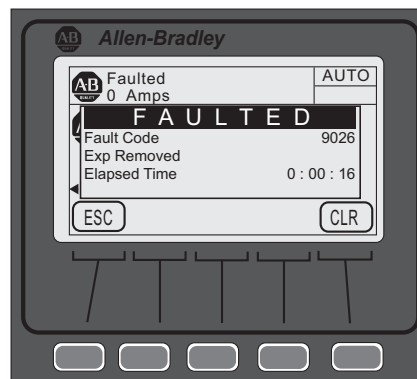

IMPORTANT Resetting a fault does not correct the cause of the fault condition. You must take corrective action before you reset the fault.

The fault display remains active as long as control power is applied. If you cycle control power, the fault is cleared, the controller re-initializes, and the display shows a status of Stopped unless the Fault condition still exists.

You can press Esc to get to another programming/diagnostic list, but the SMC-50 controller is still in a faulted state.

Clear Fault

You can clear a fault using any of the following methods:

- Program the SMC-50 to automatically clear a fault using Restart Enable, Parameter 135 or 264.
- Press the SMC-50 controller HOLD TO TEST, PUSH TO RESET button.
- Connect a N.O. push button to Option Input #1 (terminal 11) or #2 (terminal 10). Option Input #1 or #2 must be programmed for Clear Fault using Parameter 56 or 57.

TIP This can also be done with an Input from a 150-SM4 Option I/O Module.

- Cycle the control power to the SMC-50.

IMPORTANT You cannot reset an overload fault until the value of the Motor Thermal Usage, Parameter 18, is below the value programmed in OL Reset, Parameter 80. See [Enabling Option Module Functional Faults and Alarm on page 125](#) for further details.

Fault and Alarm Buffer - Parameter List

The SMC-50 stores the five most recent Fault and Alarm codes (Fault Parameter List 138 to 142, Alarm Parameter List 143 to 147) in parameter memory from newest to oldest.

Accessing the Fault and Alarm Parameters

Using the 20-HIM-A6, the fault and alarm parameter lists can be displayed in the Motor Protection File Group or Linear List parameter number search (Fault Parameter List 138 to 142, Alarm Parameter List 143 to 147). To use the File-Group method, perform the following steps:

1. From the SMC-50 controller standard power up screen, press the Folders keypad key at the lower left of the display.

TIP Make sure that the Advanced access level (located at the bottom of the <00> DEV PARAM screen) is selected before pressing ENTER. See [Parameter Access Level Modification Using the HIM on page 158](#) for additional details.

2. From the <00> DEV PARAM folder screen select File-Group, then press ENTER (number 5 from the keypad). The Port 00 Param File Group screen appears.
3. Use the down arrow key to select (highlight) FILE Motor Protection, then press ENTER (number 5 from the keypad).

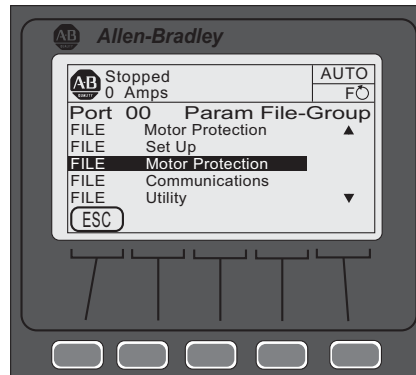

4. Use the down arrow key to select GROUP History, then press ENTER (number 5 from the keypad).

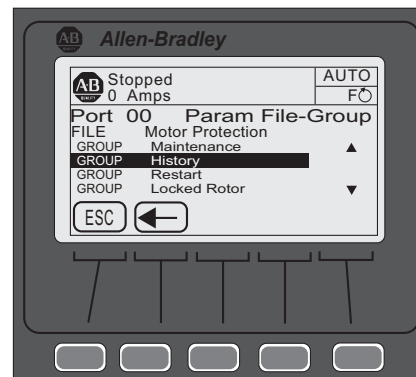

5. Use the arrow keys on the keypad to navigate to the Fault or Alarm number to review, then press ENTER (number 5 from the keypad).

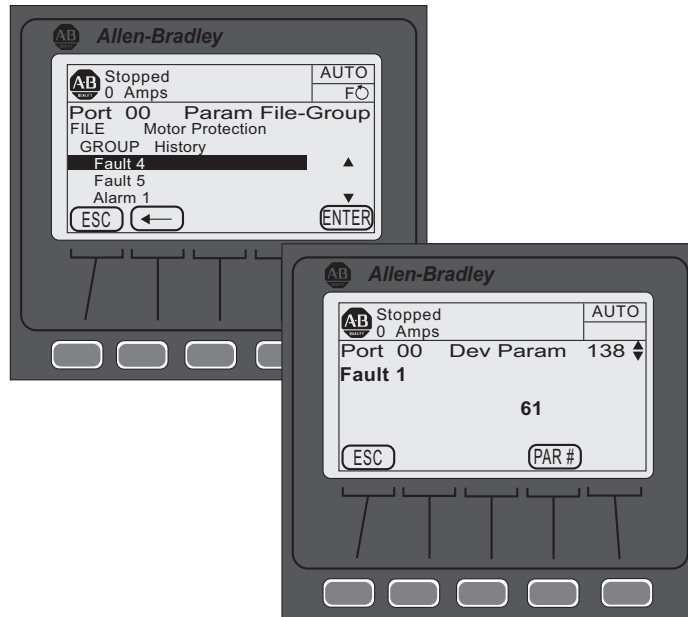

TIP In [step 5](#), Fault 61 is displayed. For Fault/Alarm code data, see [Table 126 on page 233](#).

Accessing the Fault and Alarm Buffers

In addition to the SMC-50 controller storing the most recent Alarm and Fault codes as parameters, the date and time the Fault or Alarm occurred is stored in the Fault Buffer (last five faults) and Alarm Buffer (last 100 alarms). To access Fault buffers and Alarm Buffers using the 20-HIM-A6, you must access the Diagnostic folder. To do so, perform the following steps.

1. From the SMC-50 controller standard power up screen, press the Folders key at the lower left of the display.
2. Using the right or left arrow key, display the DIAGNOSTIC folder.
3. Using the up or down arrow key, select either Faults or Alarms, then press ENTER. In this example, Faults is used.

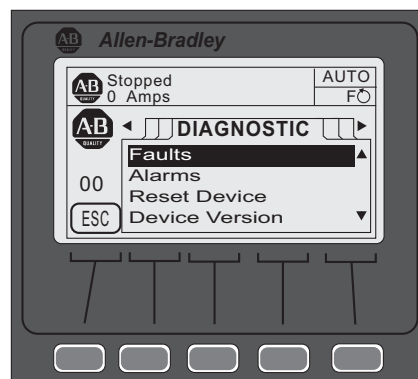

The HIM displays the five most recent Fault codes if Faults was selected. The HIM displays the 100 most recent Alarm codes with an abbreviated description if Alarm codes were selected. The most recent code is listed as 01 with the second most recent code as 02, and so on.

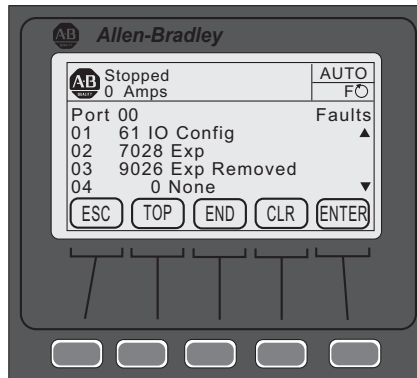

4. Select the Fault or Alarm in question, then press ENTER. The date and time that the Fault or Alarm occurred is displayed.

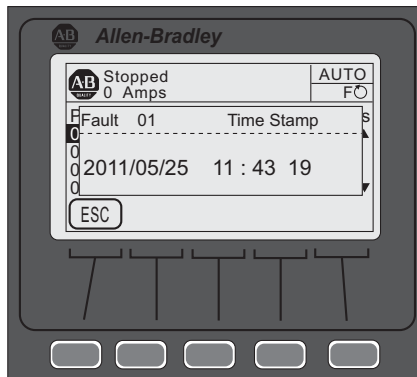

TIP The Fault/Alarm buffers are available using Connected Components Workbench software via the Explore and Device properties drop-down menu. Ensure 0-SMC-50 controller is selected from the list of Devices.

Fault Codes

The following table provides a complete cross-reference of the available fault codes and corresponding fault descriptions.

Table 125 - Fault/Alarm Code Cross-Reference

Fault/Alarm Name		Code	LED Code	Category ⁽²⁾	Host	DPI/HIM/COMM	Exp 7, 8, 9	Fault/Alarm Name	Code	LED Code	Category ⁽²⁾	Host	DPI/HIM/COMM	Exp 7, 8, 9	
Line Loss	A	1	1	D	X	—	—	Under Power Real	43	—	M	X	—	—	
	B	2						Over Power Real	44	—	M	X	—	—	
	C	3						Un Power Reac +	45	—	M	—	—	—	
Shorted SCR	A	4	1	D	X	—	—	Ov Power Reac +	46	—	M	—	—	—	
	B	5						Und Power App	47	—	M	—	—	—	
	C	6						Ov Power App	48	—	M	—	—	—	
Open Gate	A	7	2	D	X	—	—	Frequency	49	—	M	X	—	—	
	B	8						PM Hours	50	—	M	X	—	—	
	C	9						PM Starts	51	—	M	X	—	—	
SCR Overtemp		10	3	D	X	—	—	Power Quality	A	52	—	M	X	—	—
Open Bypass	A	11	2	D	X	—	—		B	53	—	M	X	—	—
	B	12						C	54	—	M	X	—	—	
	C	13						Power Quality THD V	55	—	M	X	—	—	
No Load		14	2	M	X	—	—	Power Quality THD I	56	—	M	X	—	—	
Open Load	A	15	2	M	X	—	—	Config Change	57	—	D	X	—	—	
	B	16						Ground Fault	58	—	M	—	—	X	
	C	17						Motor PTC	59	—	M	—	—	X	
Voltage Unbal		18	3	M	X	—	—	Power Pole PTC	60	3	D	X	—	—	
Oversvoltage		19	—	M	X	—	—	I/O Config	61	—	D	X	—	—	
Undersvoltage		20	—	M	X	—	—	Test Fault	62	6	D	X	—	—	
Overload		21	4	M	X	—	—								
Underload		22	—	M	X	—	—	Und PF Lag	63	—	M	—	—	—	
Jam		23	—	M	X	—	—	Und PF Lead	64	—	M	X	—	—	
Stall		24	5	M	X	—	—	Ovr PF Lag	65	—	M	X	—	—	
Phase Reversal		25	6	M	X	—	—	Ovr PF Lead	66	—	M	X	—	—	
Exp Removed		26	—	D	—	X	X	—MVAR Over	67	—	M	X	—	—	
Exp Incompat		27	—	D	—	—	X	—MVAR Under	68	—	M	X	—	—	
Expansion		28	—	D	—	X	X	RTC Battery Low	69	5	D	X	—	—	
Excess Starts		29	—	M	X	—	—	Locked Rotor	70	—	M	X	—	—	
CT Loss	A	30	4	D	X	—	—	Start ⁽³⁾	71	—	—	—	—	—	
	B	31						Slow Speed ⁽³⁾	72	—	—	—	—	—	
	C	32						Stop Option ⁽³⁾	73	—	—	—	—	—	
HAL ID		33	5	D	X	—	—	Coast ⁽³⁾	74	—	—	—	—	—	
NVS Error		34	5	D	—	—	—	Clear Fault ⁽³⁾	75	—	—	—	—	—	
V24 Recovery		35	5	D	X	—	—	Fault ⁽³⁾	76	—	—	—	—	—	
V24 Loss		36	5	D	X	—	—	Param Change ⁽³⁾	77	—	—	—	—	—	
VControl Loss		37	5	D	X	—	—	Reserved	78-99	—	—	—	—	—	

Fault/Alarm Name	Code	LED Code	Category ⁽²⁾	Host	DPI/HIM/COMM	Exp 7, 8, 9	Fault/Alarm Name	Code	LED Code	Category ⁽²⁾	Host	DPI/HIM/COMM	Exp 7, 8, 9	
TB Input ⁽¹⁾	1	38	6	D	X	—	System Faults	100-199	5	D	X	—	—	
	2	39			X	—								X
	3	40			—	—								X
	4	41			—	—								X
Current Imbal	42	7	M	X	—	—								

- (1) TB = Terminal Block Input
- (2) For Category, M= Motor; D=Device
- (3) Codes 71...77 are Event codes.

Table 126 provides an overview of the Fault and Alarm codes with Time Delay and Restart options plus a basic description of what causes each Fault or Alarm to occur.

TIP Most Faults and Alarms are individually bit enabled and disabled (F/A Bit Enab) and can have a user configurable delay time to help avoid nuisance trips (Time Delay Avail). In addition, many have the ability to automatically restart once the condition is cleared (Restart En). See Chapter 5 for additional information on Faults and Alarms.

Table 126 - Linear Listing—Fault and Alarm Code Overview

Fault/Alarm Code Name		F/A Code	Time Delay Avail.	F/A Bit Enable	Restart Enable	Description F/A= Fault and Alarm, A= Alarm, F= Fault	
Line Loss	A	1	N	Y	Y	F/A Loss of line power for Phase A, B, or C	
	B	2					
	C	3					
Shorted SCR	A	4	N	N	NA	A During prestart checks (motor stopped not running), the SMC-50 controller monitors for current flow in each individual phase.	NOTE: In Wye configurations, a single Phase A, B, or C shorted SCR is not detected until the unit is started. This fault is always enabled.
	B	5					
	C	6					
Open Gate	A	7	N	Y	Y	F/A Indicates that an abnormal condition that causes faulty firing (for example, open SCR Gate) has been sensed during the starting sequence.	
	B	8					
	C	9					
SCR Overtemp		10	N	N	NA	F The SMC-50 controller protects the SCRs from damage caused by overtemperature operation using an internally configured I ² t. NOTE: This fault is always enabled.	
Open Bypass	A	11	N	N	NA	F Open Bypass Phase A	Device senses that the bypass contactor did not close on the respective phase.
	B	12				F Open Bypass Phase B	
	C	13				F Open Bypass Phase C	
No Load		14	N	Y	Y	F/A The SMC-50 controller can determine if a load connection exists (total load lost or all load leads lost) and a No Load Fault and/or Alarm can be indicated.	
Open Load	A	15	N	Y	Y	F/A An Open Load A	Fault/Alarm indicates that the Phase X load lead connection is OFF/Open.
	B	16				F/A An Open Load B	
	C	17				F/A An Open Load C	
Voltage Unbalance		18	Y	Y	Y	F/A Indicates that when the calculated unbalance level is greater than the user-defined Fault and/or Alarm level. See Chapter 4 for calculated value details.	
Overvoltage		19	Y	Y	Y	F/A Indicates that if the average line voltage is greater than the user-defined Fault and/or Alarm level.	

Fault/Alarm Code Name	F/A Code	Time Delay Avail.	F/A Bit Enable	Restart Enable	Description	
					F/A= Fault and Alarm, A= Alarm, F= Fault	
Undervoltage	20	Y	Y	Y	F/A Indicates that if the average line voltage is less than the user-defined Fault and/or Alarm level.	
Overload	21	Y ⁽¹⁾	Y	Y	F/A Enabled in the Motor Protection Group by programming the: Overload Class, Overload Reset, Motor FLC, and Service Factor.	
Underload	22	Y	Y	Y	F/A Motor operation will halt (Fault only) if the value of the motor's average RMS current is less than the user-defined value.	
Jam	23	Y	Y	Y	F/A Indicates that the motor current increases above the user-defined Fault and or Alarm level while the motor is running at speed. This F/A condition is not active during starting or stopping.	
Stall	24	Y	Y	Y	F/A Condition exists and a Fault/Alarm is generated if the SMC-50 controller senses that the motor is NOT Up-to-Speed (UTS) at the end of the programmed starting ramp time plus the time programmed in the Stall Delay time.	
Phase Reversal	25	N	Y	Y	F/A Fault/Alarm is indicated when the incoming power to the SMC-50 controller is in any sequence other than ABC.	
Exp Removed	26	N	N	NA	F Removing an expansion module (device) (for example, a 150-SM4) from a SMC-50 controller will result in a x026 fault, where "x" is the SMC-50 controller port number (7, 8, or 9) the expansion module was installed. DPI devices (for example, 20-HIM-A6 or 20-COMM-X) will only generate this fault if its associated bit in Logix Mask parameter is set. NOTE: If an expansion module (device) (for example, a 150-SM4 is removed from a SMC-50 controller), the message "Device Conflicts Port xy Not Found" is displayed on the HIM or PC software) when power returns.	
Exp Incompat	27	N	N	NA	F Inserting an expansion module or DPI device into an incompatible controller port number or inserting an expansion module into a controller with incompatible version of firmware results in this Fault. The port number of the offending device is included as the first digit of this Fault code.	
Expansion	28	N	N	NA	F General Fault that can be generated by an expansion or peripheral device. The port number of the offending device is included as the first digit of this Fault code.	
Starts per Hour	29	N	Y	Y	F/A Starts per Hour is the maximum number of starts (user configured) within a sliding one hour window. Once the number of starts per hour is reached, any additional starts will cause a Fault/Alarm Code 29.	
CT Loss	A	30	N	N	NA	F CT Loss A (Phase A)
	B	31				F CT Loss B (Phase B)
	C	32				F CT Loss B (Phase B)
				fault occurs when current feedback is invalid. This Fault is always enabled.		
HAL ID	33	N	N	NA	F HAL ID Fault is generated if the controller determines that an incorrect (incompatible) power pole is installed. This Fault is always enabled.	
NVS Error	34	N	N	NA	F Indicates an error in the SMC-50 controller's nonvolatile memory storage. Clearing the Fault requires a change to the parameter or loading defaults (preferred). It is not cleared by cycling power. This Fault is always enabled.	
Future Use	35				Future use.	
V24 Loss	36	N	N	NA	F Indicates that the voltage level of the SMC-50 controller's internal 24V DC supply which provides power to the controller logic and on-board 24V DC I/O has fallen outside of the allowable range. This Fault is always enabled.	
VControl Loss	37	N	N	NA	F Indicates that the control voltage level of the user-applied control voltage has fallen outside the allowable upper or lower limit. This Fault is always enabled.	
TB Input	1	38	N	N	NA	F Occurs when the Control Input is configured to generate a Fault and the input condition (N.O. or N.C.) is satisfied.
	2	39				
	3	40				
	4	41				
Current Imbal	42	Y	Y	Y	F/A Exists when the calculated imbalance level is equal to or greater than the user-defined Fault/Alarm level. See Chapter 5 for calculated value details.	
Under Power Real	43	Y	Y	Y	F/A Occurs when the Real Power:	falls below the user-defined fault/alarm level.
Over Power Real	44	Y	Y	Y		rises above the user-defined fault/alarm level.
Un Power Reac +	45	Y	Y	Y	F/A Occurs when the Reactive Power	falls below the user-defined fault/alarm level.
Ov Power Reac +	46	Y	Y	Y		+:

Fault/Alarm Code Name	F/A Code	Time Delay Avail.	F/A Bit Enable	Restart Enable	Description		
					F/A= Fault and Alarm, A= Alarm, F= Fault		
Under Power App	47	Y	Y	Y	F/A Occurs when the Apparent Power+:	falls below the user-defined fault/alarm level.	
Over Power App	48	Y	Y	Y		rises above the user-defined fault/alarm level.	
Frequency	49	Y	Y	Y	F/A Occurs if the line frequency goes above or below the user-defined frequency high or frequency low Fault/Alarm level.		
PM Hours	50	N	Y	Y	F/A User-defined value which sets the number of elapsed hours (actual operating hours of the motor) before a fault/alarm is signaled indicating that preventive maintenance should be performed.		
PM Starts	51	N	Y	Y	F/A User-defined value which sets the number of starts before a fault/alarm is signaled indicating that preventive maintenance should be performed.		
Power Quality	A	52	N	Y	Y	F/A Fault condition which indicates that the starter is not properly firing its:	A Phase SCR.
	B						B Phase SCR.
	C						C Phase SCR.
Power Quality THD V	55	Y	Y	Y	F/A Indicates a high, voltage based total harmonic distortion level.		
Power Quality THD I	56	Y	Y	Y	F/A Indicates a high, current based total harmonic distortion level.		
Config Change	57	N	Y	Y	F/A Indicates any change to the SMC-50 controller parameter configuration.		
Ground Fault	58	Y	Y	Y	F/A Indicates the value of Ground Fault Current goes above the user-defined fault/alarm level. NOTE: A 150-SM2 Ground Fault PTC Feedback Module and 825-CBCT Core Balanced Ground Fault Sensor are required to configure this Fault/Alarm.		
Motor PTC	59	N	Y	Y	F/A Indicates the embedded motor PTC sensing device is tripped/closed due to a motor overtemperature condition. NOTE: A 150-SM2 Ground Fault PTC Feedback Module is required to configure this Fault/Alarm.		
Power Pole PTC	60	N	N	NA	F Built-in Power Pole PTC Temperature Sensor is used to measure power pole temperature. A fault occurs when the temperature rises above a predetermined level. This fault is always enabled.		
I/O Config	61	N	N	NA	F Occurs when any input is programmed as a start or slow speed and no input is configured as a coast or stop. The fault occurs when the start or maneuver is attempted (the motor will not start). This fault is also generated when the input configuration changes from one that cannot start the motor to one that can. It will also be generated when a parameter is changed from an input that can stop the motor to one that cannot. This fault is always enabled.		
Test Fault	62	N	N	NA	F Occurs when the Push-to-Reset, Hold-to-Test push button on the SMC-50 controller is pushed for ≥ 3 seconds but < 10 seconds.		
Under PF Lag	63	Y	Y	Y	F/A Occurs when the lagging Power Factor goes below the user-defined fault/alarm level.		
Under PF Lead	64	Y	Y	Y	F/A Occurs when the leading Power Factor goes below the user-defined fault/alarm level.		
Over PF Lag	65	Y	Y	Y	F/A Occurs when the lagging Power Factor goes above the user-defined fault/alarm level.		
Over PF Lead	66	Y	Y	Y	F/A Occurs when the leading Power Factor goes above the user-defined fault/alarm level.		
-MVAR Over	67	Y	Y	Y	F/A Occurs when the magnitude of the Reactive Power rises above the user-defined level.		
-MVAR Under	68	Y	Y	Y	F/A Occurs when the magnitude of the Reactive Power falls below the user-defined level.		
RTC Battery Low	69	N	N	NA	A Occurs when the SMC-50 controller battery that maintains the value of the Real Time Clock (RTC) is low and needs to be replaced immediately. Alarm is always enabled.		
Locked Rotor	70	Y	Y	Y	F/A Occurs when the motor current increases above the user-defined fault/alarm level while the motor is in any running mode. This F/A condition is not active during starting or stopping.		

Fault/Alarm Code Name	F/A Code	Time Delay Avail.	F/A Bit Enable	Restart Enable	Description	
					F/A= Fault and Alarm, A= Alarm, F= Fault	
Start	71	NA	NA	NA	This is an Event Code and is stored in the Alarm Buffer for:	Start Event tracking.
Slow Speed	72	NA	NA	NA		Slow Speed Event tracking.
Stop Option	73	NA	NA	NA		Stop Option Event tracking.
Coast	74	NA	NA	NA		Coast Event tracking.
Clear Fault	75	NA	NA	NA		Clear Fault Event tracking.
Fault	76	NA	NA	NA		Fault Event tracking.
Parm Change	77	NA	NA	NA		Parameter Change Event tracking.
Reserved	78...99	N	N	N	Future Use.	
System Faults	100...199	N	N	NA	A general Fault/Alarm typically associated with the SMC-50 controller hardware (for example, system Watchdog Time failure).	

(1) Overload is inherently a time-based fault.

Auxiliary Relay Output Fault or Alarm Indication

You can program Auxiliary Relay Output contacts for Fault or Alarm, N.O., or N.C. indication. You can also configure an ON or OFF Delay Time. Basic parameter setup (without N.C. or timed functions) is in the Setup / I/O Parameter Group. Full configuration is available from the Setup / I/O Parameter Group.

Troubleshooting

Introduction

For safety of maintenance personnel and others who might be exposed to electrical hazards associated with maintenance activities, follow the local safety related work practices (for example, NFPA 70E, Part II in the United States). Maintenance personnel must be trained in the safety practices, procedures, and requirements that pertain to their respective job assignments.



SHOCK HAZARD: Hazardous voltage is present in the motor circuit even when the SMC-50 controller is off. To avoid shock hazard, disconnect main power before working on the controller, motor, and control devices (for example, Start-Stop push buttons). Procedures that require parts of the equipment to be energized during troubleshooting, testing, etc., must be performed by properly qualified personnel using appropriate local safety work practices and precautionary measures.



ATTENTION: Disconnect the controller from the motor before measuring insulation resistance (IR) of the motor windings. Voltages used for insulation resistance testing can cause SCR failure. Do not make any measurements on the controller with an IR tester (megger).

The flowchart in [Figure 102](#) aids in quick troubleshooting.

- TIP** The time it takes for the motor to come up to speed may differ from the time programmed. This depends upon the motor and load characteristics.
- TIP** Depending upon the application, the braking options (SMB and Slow Speed) may cause some vibration or noise during the stopping cycle. To minimize vibration or noise, lower the braking current adjustment. If this is a concern in your application, please consult your local Rockwell Automation sales office or Allen-Bradley distributor before you implement the braking options.

Figure 102 - Troubleshooting Flowchart

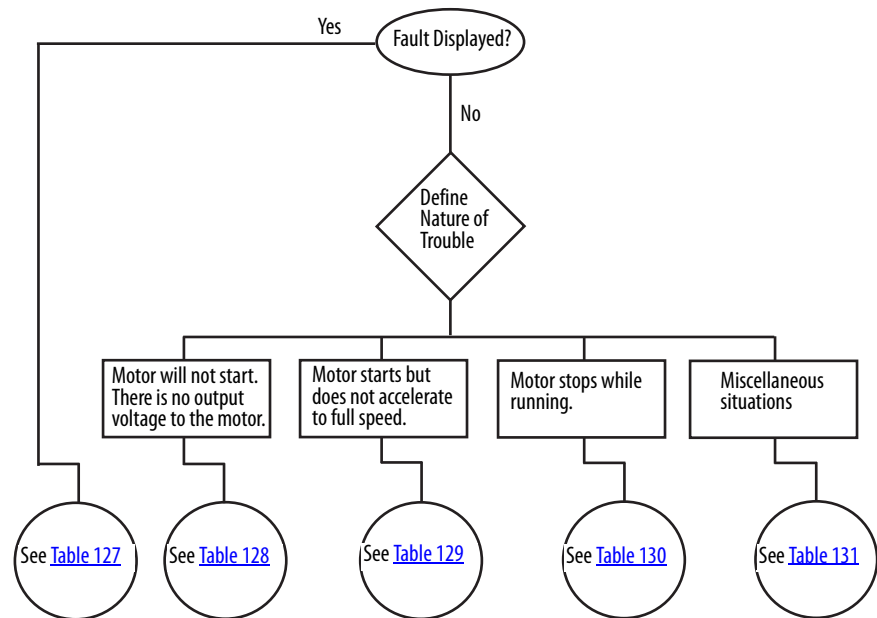

Table 127 - Fault Display Explanation

Display	Fault Code	Fault Enabled	Possible Causes	Possible Solutions
Line Loss (with phase indication)	1, 2, 3	Prestart and Running	<ul style="list-style-type: none"> High impedance line connection Missing supply phase Motor not connected properly Incoming 3-phase voltage instability 	<ul style="list-style-type: none"> Check for line and load loose connections. Check for open line (for example, blown fuse). Check for open line lead(s). Verify power quality. Disable this fault/alarm feature.
Shorted SCR (with phase indication)	4, 5, 6	In All Modes	<ul style="list-style-type: none"> Shorted power module. 	<ul style="list-style-type: none"> Check for shorted SCR, perform a resistance check (see Power Module Check section), or replace power module if necessary.
Open Gate (with phase indication)	7, 8, 9	Start or Stop	<ul style="list-style-type: none"> Open gate circuitry Loose gate lead 	<ul style="list-style-type: none"> Perform a resistance check (see Power Module Check section), replace power module if necessary. Remove control module from the power section and check gate lead connections (TB5, TB6, and TB 7) are firmly seated to the control module. Disable this fault/alarm feature.
SCR Overtemp or PTC Power Pole	10 or 60	In All Modes	<ul style="list-style-type: none"> Controller ventilation blocked Controller duty cycle exceeded Fan failure Ambient temperature limit exceeded Failed thermistor 	<ul style="list-style-type: none"> Check for proper controller ventilation. Check application-appropriate duty cycle. Wait for controller to cool or provide external cooling if ambient temperature is high. Check for fan operation. Replace fan, if necessary. Replace power module or control module as needed.
Open Bypass	11, 12, 13	In All Modes	<ul style="list-style-type: none"> Control voltage is low Inoperable power module bypass 	<ul style="list-style-type: none"> Check control voltage power supply. Replace power module. Check control module TB2... TB4 and TB5... TB7 for proper order and secureness. Make sure that no auxiliary contact is set to "external bypass".
No Load or Open Load (with Phase Indication)	14, 15, 16, 17	Prestart Only	<ul style="list-style-type: none"> Loss of load side power wiring with phase indication (15=A, 17=C) Start command cycled unexpectedly with motor rotating 	<ul style="list-style-type: none"> Check all load side power connections. Check motor windings (megger).
Voltage Unbalance or Current Imbalance	18 or 42	Running	<ul style="list-style-type: none"> Power line unbalance is greater than the programmed value The delay time programmed is too short for the application 	<ul style="list-style-type: none"> Check the power system and correct if necessary or change the programmed value. Extend the delay time to match the application requirements. Disable this fault/alarm feature.

Display	Fault Code	Fault Enabled	Possible Causes	Possible Solutions
Overvoltage	19	Running	<ul style="list-style-type: none"> Power line grid voltage is greater than the programmed value Abnormal voltage regulation The parameter settings and/or delay time programmed are not suited for the application 	<ul style="list-style-type: none"> Check the power system and correct if necessary. NOTE: If the power source is a backup generator, check the stability of the generator voltage regulator. Replace if necessary. Modify the parameter and/or extend the delay time to match the application requirements. Disable this fault/alarm feature.
Undervoltage	20	Running	<ul style="list-style-type: none"> Power line grid voltage is less than the programmed value Abnormal voltage regulation The parameter settings and/or delay time programmed are not suited for the application 	<ul style="list-style-type: none"> Check the power system and correct if necessary. NOTE: If the power source is a backup generator, check the stability of the generator voltage regulator. Replace if necessary. Modify the parameter and/or extend the delay time to match the application requirements. Disable this fault/alarm feature.
Overload	21	Running	<ul style="list-style-type: none"> Motor overloaded Overload parameters are not matched to the motor 	<ul style="list-style-type: none"> Check motor overload condition. Check programmed values for overload class and motor FLC; verify current draw of the motor. Disable this fault/alarm feature.⁽³⁾
Underload	22	Running	<ul style="list-style-type: none"> Broken motor shaft, belt, grating, etc. Pump cavitation Programmed setting incorrect for application 	<ul style="list-style-type: none"> Check machine drive components and loading. Check pump system. Repair or replace motor. Check programmed settings. Disable this fault/alarm feature.
Jam	23	Running	<ul style="list-style-type: none"> Motor current has exceeded the user programmed jam level for the programmed time 	<ul style="list-style-type: none"> Correct source of jam or excessive loading. Check programmed time value. Disable this fault/alarm feature.
Stall	24	Running	<ul style="list-style-type: none"> The motor did not reach full speed by the end of the programmed ramp time Incorrect programmed setting 	<ul style="list-style-type: none"> Check pump system, machine drive components, and loading; repair or replace motor, if necessary. Check programmed settings. Disable this fault/alarm feature.
Phase Reversal	25	Prestart Only	<ul style="list-style-type: none"> The controller is not detecting incoming supply voltage in the expected ABC sequence 	<ul style="list-style-type: none"> Check power wiring and correct, if necessary. Disable this fault/alarm feature.
Exp Removed	x026 ⁽²⁾	In All Modes	<ul style="list-style-type: none"> Expansion module is loose or removed Expansion module is defective 	<ul style="list-style-type: none"> Reseat or replace the expansion module connector to the control module and tighten module screws. Replace defective module.
Exp Incompat	x027 ⁽²⁾	In All Modes	<ul style="list-style-type: none"> Expansion module is inserted into an incompatible control module port number Controller firmware is not compatible with the expansion module Expansion module is defective 	<ul style="list-style-type: none"> Insert the expansion module into a compatible control module port. Update the control module firmware Replace defective module.
Expansion	x028 ⁽²⁾	In All Modes	<ul style="list-style-type: none"> Expansion module is loose or removed Expansion module is defective Expansion module is inserted into an incompatible control module port number Controller firmware is not compatible with the expansion module 	<ul style="list-style-type: none"> Reseat and/or replace loose/removed module and tighten module screws. Replace defective expansion module. Update control module firmware.
Starts per Hour	29	Starting	<ul style="list-style-type: none"> The number of starts within the last hour has exceeded the programmed value Programmed setting is incorrect for the application 	<ul style="list-style-type: none"> Wait for the hour to expire, then restart the motor. Reduce the actual number of starts per hour or increase the programmed start time (if allowed by the application) and controller thermal limits. Turn off this fault/alarm feature.
CT Loss: A, B, or C	30, 31, or 32	In All Modes	<ul style="list-style-type: none"> Loose CT cable connection between the power section and the control module Phase A (F30), B (F31), or C (F32) current transformer feedback circuit has failed Option Module 150-SM2 with external CT operation (Fault Code 7030, 8030) 	<ul style="list-style-type: none"> Remove the control module from the power section; verify connectors TB2 (A), TB3 (B), and TB4 (C) are firmly seated to the control module. Replace the control module and/or the power section. Inspect the CT sensor cables for loose connections; check CTs for damage; repair/replace CTs if necessary; replace 150-SM2 option module if necessary.
Hall ID	33	In All Modes	<ul style="list-style-type: none"> Loose cables between the controller and power section. Incompatible power section installed with the controller 	<ul style="list-style-type: none"> Remove the control module from the power section; verify connectors TB2 (A), TB3 (B), and TB4 (C) are firmly seated to the control module. Check the power section and replace, if necessary.
NVS Error	34	In All Modes	<ul style="list-style-type: none"> Controller memory corrupted Option module error (Fault Code 7034, 8034, or 9034) 	<ul style="list-style-type: none"> Modify a parameter or load parameter defaults (preferred) and reload the customer-specific parameters. Check the option module sensor cables. Replace the option module.
Future Use	35	NA	NA	NA

Display	Fault Code	Fault Enabled	Possible Causes	Possible Solutions
V24 Loss	36	In All Modes	<ul style="list-style-type: none"> Loose connection at Control Terminals 1 (+L1) and 2 (-L2) Excessive load on internal 24V supply Low line voltage condition 	<ul style="list-style-type: none"> Check the control power and verify it is within the specification; check the line connections and grounding to the SMC-50 controller control terminals. Replace the control module.
V Control Loss	37	In All Modes	<ul style="list-style-type: none"> Loose connection at Control Terminals 1 (+L1) and 2 (-L2) Low line voltage condition 	<ul style="list-style-type: none"> Check the control power and verify it is within the specification; check the connections and grounding to the SMC-50 controller control terminals. Replace the control module.
TB Input: 1, 2, 3 and 4	38, 39, 40, and 41	In All Modes	<ul style="list-style-type: none"> The condition to generate the TB Input fault is satisfied Terminal wiring configuration or fault N.O./N.C. configuration of input is incorrect 	<ul style="list-style-type: none"> Clear the fault condition. Rewire and/or reconfigure the input.
Voltage Unbalance or Current Imbalance	42 or 18	Running	<ul style="list-style-type: none"> Power line unbalance is greater than the programmed value The delay time programmed is too short for the application 	<ul style="list-style-type: none"> Check the power system and correct if necessary or change the programmed value. Extend the delay time to match the application requirements. Disable this fault/alarm feature.
Und Pwr Real ⁽¹⁾	43	Running	<ul style="list-style-type: none"> Abnormally reduced real (MW) power draw by the motor possibly due to broken mechanical connection (belt, gears, etc.) between motor and load Pump cavitation Programmed setting is incorrect for the application 	<ul style="list-style-type: none"> Repair/replace the condition causing the reduced real power load. Modify the programmed fault/alarm parameters to better suit the application. Disable the fault/alarm feature.
Ovr Pwr Real ⁽¹⁾	44	Running	<ul style="list-style-type: none"> Abnormally high real (KW) power draw by the motor Programmed setting is incorrect for the application 	<ul style="list-style-type: none"> Repair/replace the condition causing the high KW power draw. Modify the programmed fault/alarm parameters to better suit the application. Disable the fault/alarm feature.
Un Pwr React ⁽¹⁾	45	Running	<ul style="list-style-type: none"> Abnormally reduced reactive (+MVAR) power produced by the motor Programmed setting is incorrect for the application 	<ul style="list-style-type: none"> Repair/replace the condition causing the reduced +MVAR power draw. Modify the programmed fault/alarm parameters to better suit the application. Disable the fault/alarm feature.
Ov Pwr React ⁽¹⁾	46	Running	<ul style="list-style-type: none"> Abnormally high reactive (+MVAR) power produced by the motor Programmed settings are incorrect for the application 	<ul style="list-style-type: none"> Repair/replace the condition causing the high +MVAR power draw. Modify the programmed fault/alarm parameters to better suit the application. Disable the fault/alarm feature.
Und Pwr App ⁽¹⁾	47	Running	<ul style="list-style-type: none"> Abnormally reduced apparent (MVA) power draw by the motor Programmed settings are incorrect for the application 	<ul style="list-style-type: none"> Repair/replace the condition causing the reduced +MVA power draw. Modify the programmed fault/alarm parameters to better suit the application. Disable the fault/alarm feature.
Ovr Pwr App ⁽¹⁾	48	Running	<ul style="list-style-type: none"> Abnormally high apparent (MVA) power draw by the motor Programmed settings are incorrect for the application 	<ul style="list-style-type: none"> Repair/replace the condition causing the high +MVA power draw. Modify the programmed fault/alarm parameters to better suit the application. Disable the fault/alarm feature.
Frequency	49	Running	<ul style="list-style-type: none"> Speed control regulation system of the generator prime mover (for example, diesel engine) is unable to adjust to current load conditions or is defective Abnormal power grid connections; power generation source is operating outside its normal frequency limits or range 	<ul style="list-style-type: none"> Reduce the generator load, increase generator output, replace the speed control system, or generator. NOTE: For a diesel generator system, Rockwell Automation recommends it be oversized by a factor of three for Soft Start applications. Contact the power company for additional information. Modify the programmed fault/alarm parameters to better suit the application.
PM Hours	50	In All Modes	<ul style="list-style-type: none"> The number of hours programmed in the PM Hours Parameter has been reached 	<ul style="list-style-type: none"> Perform required maintenance and reset the PM Hours parameter. Disable this fault/alarm feature.
PM Starts	51	Pre-Start	<ul style="list-style-type: none"> The number of Starts programmed in the PM Start Parameter has been reached 	<ul style="list-style-type: none"> Perform required maintenance and reset the PM Hours parameter. Disable this fault/alarm feature.
Power Quality: A, B, or C	52, 53, or 54	Start or Stop	<ul style="list-style-type: none"> Incoming 3-phase voltage instability or distortion High impedance line or load connection 	<ul style="list-style-type: none"> Check supply voltage for capability to start/stop the motor; check for loose connections on the line side or motor side of the power wires. Verify and correct the input power quality issue Disable this fault/alarm feature.

Display	Fault Code	Fault Enabled	Possible Causes	Possible Solutions
Power Quality: THD V	55	Running	<ul style="list-style-type: none"> The current mix of loads on the power line contributing to the THD V has exceeded the programmed THD V level and/or time 	<ul style="list-style-type: none"> Check the mix of loads (what was added, what was changed); modify the load mix if necessary. Change the programmed THD V level and/or delay time. Disable this fault/alarm feature.
Power Quality: THD I	56	Running	<ul style="list-style-type: none"> The current mix of loads on the power line contributing to the THD I has exceeded the programmed THD I level and/or time 	<ul style="list-style-type: none"> Check the mix of loads (what was added, what was changed); modify the load mix if necessary. Change the programmed THD I level and/or delay time. Disable this fault/alarm feature.
Config Change	57	In All Modes	<ul style="list-style-type: none"> A controller parameter has been modified 	<ul style="list-style-type: none"> Disable this fault/alarm feature.
Ground Fault	X058 ⁽²⁾	Running	<ul style="list-style-type: none"> The ground fault current level has exceeded the programmed value The delay time is too short for the application <p>NOTE: An optional 150-SM2 Ground Fault PTC Module is required for this fault.</p>	<ul style="list-style-type: none"> Check the power system and motor; correct if necessary. Check the programmed ground fault levels to match application requirements; modify if necessary. Extend the delay time to match the application requirements. Disable this fault/alarm feature.
Motor PTC	X059 ⁽²⁾	In All Modes	<ul style="list-style-type: none"> Motor ventilation is blocked. Motor duty cycle is exceeded PTC open or shorted <p>NOTE: An optional 150-SM2 Ground Fault PTC Module is required for this fault.</p>	<ul style="list-style-type: none"> Check for proper ventilation. Check application duty cycle. Wait for motor to cool or provide external cooling, then check resistance of PTC. Disable this fault/alarm feature.
SCR Overtemp or PTC Power Pole	60 or 10	In All Modes	<ul style="list-style-type: none"> Controller ventilation blocked Controller duty cycle exceeded Fan failure Ambient temperature limit exceeded Failed thermistor 	<ul style="list-style-type: none"> Check for proper controller ventilation. Check application-appropriate duty cycle. Wait for controller to cool or provide external cooling if ambient temperature is high. Check for fan operation. Replace fan, if necessary. Replace power module or control module as needed.
I/O Config	61	Pre-Start	<ul style="list-style-type: none"> The configuration of the control I/O does not meet the system rules as defined in Configuration Functions on page 151. 	<ul style="list-style-type: none"> Modify the control I/O configuration to meet the established rules.
Test Fault	62	In All Modes	<ul style="list-style-type: none"> The SMC-50 controller's Push to Reset/Hold to Test push button was pressed for more than three seconds, but less than ten The SMC-50 controller's Push to Reset/Hold to Test push button is stuck or damaged 	<ul style="list-style-type: none"> To reset the Test fault, press the Push to Reset/Hold to Test push button for less than two seconds. NOTE: Only use the Push to Reset push button when absolutely necessary. Attempt to dislodge the push button or replace the control module if necessary.
Und PF Lag	63	In All Modes	<ul style="list-style-type: none"> A lagging PF is abnormally under the typical value; less inductance or more capacitance has been introduced to the power line A programmed setting or time value is incorrect for the application 	<ul style="list-style-type: none"> Determine the cause of the reduced Lagging PF. Modify the programmed fault/alarm parameters to better suit the application. Disable the fault/alarm feature.
Und PF Lead	64	Running	<ul style="list-style-type: none"> A leading PF is abnormally under the typical value; less inductance or more capacitance has been introduced to the power line A programmed setting or time value is incorrect for the application 	<ul style="list-style-type: none"> Determine the cause of the reduced Leading PF Modify the programmed fault/alarm parameters to better suit the application. Disable the fault/alarm feature.
Ovr PF Lag	65	Running	<ul style="list-style-type: none"> A lagging PF is abnormally over the typical value; more inductance or less capacitance has been introduced to the power line A programmed setting or time value is incorrect for the application 	<ul style="list-style-type: none"> Determine the cause of the Over PF Lagging Modify the programmed fault/alarm parameters to better suit the application. Disable the fault/alarm feature.
Ovr PF Lead	66	Running	<ul style="list-style-type: none"> A leading PF is abnormally under the typical value; less inductance or more capacitance has been introduced to the power line A programmed setting or time value is incorrect for the application 	<ul style="list-style-type: none"> Determine the cause of the Over PF Leading. Modify the programmed fault/alarm parameters to better suit the application. Disable the fault/alarm feature.
-MVAR Over ⁽¹⁾	67	Running	<ul style="list-style-type: none"> Abnormally high reactive (-MVAR) power consumed by the motor Programmed settings are incorrect for the application 	<ul style="list-style-type: none"> Repair/replace the condition causing the high -MVAR. Modify the programmed fault/alarm parameters to better suit the application. Disable the fault/alarm feature.
-MVAR Under ⁽¹⁾	68	Running	<ul style="list-style-type: none"> Abnormally reduced reactive (-MVAR) power consumed by the motor Programmed settings are incorrect for the application 	<ul style="list-style-type: none"> Repair/replace the condition causing the reduced -MVAR. Modify the programmed fault/alarm parameters to better suit the application. Disable the fault/alarm feature.
RTC Battery Low	69	Pre-Start	<ul style="list-style-type: none"> Battery reading is below the acceptable level to potentially maintain the real time clock and calendar 	<ul style="list-style-type: none"> Replace battery (CR2032) as soon as possible.

Display	Fault Code	Fault Enabled	Possible Causes	Possible Solutions
Locked Rotor	70	In All Modes	<ul style="list-style-type: none"> Motor has stalled; rotor is not turning 	<ul style="list-style-type: none"> Check motor and load for binding or jammed conditions Parameters are not adequately configured for the application. Review and adjust. Disable the fault/alarm feature.
Start	71	Starting	<ul style="list-style-type: none"> A start event (command) has occurred. This is not a fault. 	<ul style="list-style-type: none"> NA
Slow Speed	72	Slow Speed	<ul style="list-style-type: none"> A slow speed event (command) has occurred. This is not a fault. 	<ul style="list-style-type: none"> NA
Stop Option	73	Stop Option	<ul style="list-style-type: none"> A stop option event (command) has occurred. This is not a fault. 	<ul style="list-style-type: none"> NA
Coast	74	Coast	<ul style="list-style-type: none"> A coast-to-stop event (command) has occurred. This is not a fault. 	<ul style="list-style-type: none"> NA
Clear Fault	75	Faulted	<ul style="list-style-type: none"> A clear fault event (command) has occurred. This does not generate a fault. 	<ul style="list-style-type: none"> NA
Fault	76	Faulted	<ul style="list-style-type: none"> A fault event (command) has occurred. This is not a fault. 	<ul style="list-style-type: none"> NA
Param Change	77	Stopped	<ul style="list-style-type: none"> A change to one of the controller parameters has occurred. This is not a fault. 	<ul style="list-style-type: none"> NA
Reserved	78...99	NA	<ul style="list-style-type: none"> NA 	<ul style="list-style-type: none"> NA
System Faults	100...199	In All Modes	<ul style="list-style-type: none"> There is an issue with the control module wiring The control module is defective 	<ul style="list-style-type: none"> Review the control module wiring. Ensure the ground terminal is secure and connected to the system's earth ground. Ensure an RC snubber/suppressor is connected to all inductive loads in the control circuit. See input wiring. Replace the control module.

- (1) The Real, Reactive, and Apparent Power faults/alarms are best suited to provide indication of an abnormal running operation of the motor or system which another parameter (for example, Underload, Overload, Jam, Stall, etc.) does not provide. To understand what is an abnormal running operation, you need to determine a "normal" or "typical" value, usually established during system startup.
- (2) "X" indicates a port number in which the expansion module resides in the SMC-50 controller.
- (3) If controller based motor overload is disabled, external motor overload protection should be used.

Table 128 - Motor Will Not Start—No Output Voltage to the Motor

Display	Possible Cause	Possible Solutions
Fault displayed	<ul style="list-style-type: none"> See fault description 	<ul style="list-style-type: none"> See Table 127 addressing fault conditions
HIM display is blank	<ul style="list-style-type: none"> Failed HIM Control voltage is absent Failed control module HIM connection is loose 	<ul style="list-style-type: none"> Check control wiring and correct if necessary Check HIM connection Cycle control power Replace HIM only Replace control module only
Stopped 0.0 Amps	<ul style="list-style-type: none"> Pilot devices SMC Enable input is open at terminal 9 Configured or wired input terminals are not wired correctly Start-Stop control has not been enabled for the human interface module Control voltage Failed control module 	<ul style="list-style-type: none"> Check wiring; follow the instructions on page 217 to enable control capability. Check control voltage Replace control module
Starting	<ul style="list-style-type: none"> One or more power phases are missing Isolation contactor (if used) is not picking up 	<ul style="list-style-type: none"> Check power system Check that the SMC-50 controller Aux. relay output controlling the Isolation Contactor is configured to "Normal". Check the Isolation Contactor for proper operation

Table 129 - Motor Rotates but Does Not Accelerate to Full Speed

Display	Possible Cause	Possible Solutions
Fault displayed	<ul style="list-style-type: none"> See fault description 	<ul style="list-style-type: none"> See Table 127 addressing fault conditions
Starting	<ul style="list-style-type: none"> Mechanical problems Inadequate Current Limit setting Failed control module 	<ul style="list-style-type: none"> Check for binding or external loading and correct Check motor Adjust the Current Limit Level to a higher setting Replace control module

Table 130 - Motor Stops While Running

Display	Possible Cause	Possible Solutions
Fault displayed	<ul style="list-style-type: none"> See fault description 	<ul style="list-style-type: none"> See addressing fault conditions
HIM display is blank	<ul style="list-style-type: none"> Failed HIM Control voltage is absent Failed control module HIM connection is loose 	<ul style="list-style-type: none"> Replace HIM Check control wiring and correct if necessary Replace control module Check HIM connection
Stopped 0.0 Amps	<ul style="list-style-type: none"> Pilot devices Failed control module 	<ul style="list-style-type: none"> Check control wiring and correct if necessary Replace control module
Starting	<ul style="list-style-type: none"> One or more power phases are missing Failed control module 	<ul style="list-style-type: none"> Check power system Replace control module

Table 131 - Miscellaneous Situations

Situation	Possible Cause	Possible Solutions
Motor current and voltage fluctuates	<ul style="list-style-type: none"> Motor Erratic Load 	<ul style="list-style-type: none"> Verify type of motor as a standard squirrel cage induction motor Check load conditions
Erratic operation	<ul style="list-style-type: none"> Loose connections 	<ul style="list-style-type: none"> Shut off all power to controller and check for loose connections
Accelerates too fast	<ul style="list-style-type: none"> Starting time Initial torque Current limit setting Kickstart 	<ul style="list-style-type: none"> Increase starting time Lower initial torque setting Decrease current limit setting Lower kickstart time or turn off
Accelerates too slow	<ul style="list-style-type: none"> Starting time Initial torque Current limit setting Kickstart 	<ul style="list-style-type: none"> Decrease starting time Increase initial torque setting Increase current limit setting Increase kickstart time or turn off
Fan does not operate ⁽¹⁾	<ul style="list-style-type: none"> Control wiring Failed fan(s) 	<ul style="list-style-type: none"> Check control wiring and correct if necessary Replace fan module
Motor stops too quickly with Soft Stop option	<ul style="list-style-type: none"> Time setting 	<ul style="list-style-type: none"> Verify the programmed stopping time and correct if necessary
Motor stops too slowly with Soft Stop option	<ul style="list-style-type: none"> Stopping time setting Misapplication 	<ul style="list-style-type: none"> Verify the programmed stopping time and correct if necessary The Soft Stop option is intended to extend the stopping time for loads that stop suddenly when power is removed from the motor.
Fluid surges with pumps still occur with the Soft Stop option	<ul style="list-style-type: none"> Misapplication 	<ul style="list-style-type: none"> Soft Stop ramps voltage down over a set period of time. In the case of pumps, the voltage may drop too rapidly to prevent surges. A closed loop system such as Pump Control would be more appropriately suited.
Motor overheats	<ul style="list-style-type: none"> Duty cycle 	<ul style="list-style-type: none"> Preset Slow Speed and SMB options: Extended operation at slow speeds reduces motor cooling efficiency. Consult motor manufacturer for motor limitations. Smart Motor Braking option: Check duty cycle. Consult motor manufacturer for motor limitations.
Motor short circuit	<ul style="list-style-type: none"> Winding fault 	<ul style="list-style-type: none"> Identify fault and correct. Check for shorted SCR; replace if necessary. Ensure power terminals are secure.

(1) Fan operation is controlled by the SMC-50 Control Module. The fan may not run in low ambient temperature conditions.

Power Module Check

If you need to check a power module, use this procedure.



ATTENTION: To avoid shock hazard, disconnect main and control power before working on the controller, motor, or control devices such as Start/Stop push buttons.



ATTENTION: Make sure that wires are properly marked and programmed parameter values are recorded.

Shorted SCR Test

1. Using an ohm meter, measure the resistance between the line and load terminals of each phase on the controller. (L1-T1, L2-T2, and L3-T3)

The resistance should be greater than 5,000 Ω . Replace the power assembly if this reading is not reached. See publication [150-TD009](#) for the list of Spare/Replacement SMC-50 controller parts.

Parameter Information

SMC-50 Controller Information

This section details the parameter information for the SMC-50 controller.

Table 132 - Parameter 1...18

No.	Name	Units	Min./Max. Values	Default Value	Enum Text	Description	Read/Write Access
1	Volts Phase	PP Ave	0/700	0	NA	Displays the calculated average voltage of the applied three phase to phase line voltages being measured by the SMC-50 controller.	R
2		A-B				Displays the Phase A to Phase B voltage applied to the SMC-50 controller at the supply terminals.	
3		B-C				Displays the Phase B to Phase C voltage applied to the SMC-50 controller at the supply terminals.	
4		C-A				Displays the Phase C to Phase A voltage applied to the SMC-50 controller at the supply terminals.	
5	Current Phase	Ave	0/15000	0	NA	Displays the average of the three phase currents flowing through the SMC Power section to the load.	R
6		A				Displays the Current flowing through the Phase A power pole of the SMC Power section to the load.	
7		B				Displays the Current flowing through the Phase B power pole of the SMC Power section to the load.	
8		C				Displays the Current flowing through the Phase C power pole of the SMC Power section to the load.	
9	Torque	%	-5.0/30.0	0.0	NA	Displays the true electromechanical torque calculated based on current and voltage feedback. For this reading to display correctly, you must set the value for Rated Torque parameter.	R
10	Real Power	MW	-1000.000/1000.00	0.000	NA	Displays the total Real Power.	R
11	Real Energy	MWH	-1000.000/1000.00	0.000	NA	Displays the Real Energy, where Real Energy equal to Real Power X Time. This parameter is updated every 1/10 of an hour (6 minutes).	R
12	Elapsed Time	Hours	0.0/50000.0	0.0	NA	Displays the elapsed motor running time since the last reset of the Elapsed timer by you.	R
13	Elapsed Time 2	Hours	0.0/50000.0	0.0	NA	Displays the elapsed motor running time since the control module was manufactured.	R
14	Running Time	Hours	0.0/50000.0	0.0	NA	Displays the time the motor has been running since the last start command. This value goes to zero when a motor is restarted after a stop command or fault.	R
15	Energy Savings	%	0/100	0	NA	Displays the energy saving when the energy saving mode is enabled.	R
16	Meter Reset	—	0/4	0	—	Lets you reset various timers and counters by selecting the appropriate reset option.	R/W
					Ready	Ready state of parameter, waiting for selection.	
					Elapsed Timer	Zero the elapsed timer.	
					Time to PM	Resets the Time to PM timer to the value set in parameter PM Hours (126).	
Starts to PM	Reset the Starts to PM counter to the value set in parameter PM Starts (127).						
17	Power Factor	—	-1.00/1.00	0.00	NA	Displays the cosine of the phase angle between the voltage and current. A positive values is leading and negative value is lagging.	R
18	Motor Therm Usage	%MTU	0/200	0	NA	Displays the thermal capacity utilized in the motor overload algorithm. A value of 100% results in a motor overload fault. This value can exceed 100%, depending on the rate at which the motor is heating before an overload trip.	R

Table 133 - Parameter 19...42

ENUM Text is not applicable for the parameters in this table.

No.	Name	Units	Min./Max. Values	Default Value	Description	Read/Write Access	
19	Time to OL Trip	Secs	0/1000	0	Displays the estimated time before an overload trip occurs if the present operating conditions persist. If operating below ultimate trip current the value displays the max value.	R	
20	Time to OL Reset	Secs	0/1000	0	Displays the estimated time until the motor overload fault can be reset. The MTU reset level is set by the OL reset parameter (80).	R	
21	Time to PM	Hrs	0/1000	0	Displays the estimated time to a preventive maintenance event if enabled. The scheduled time for a PM event is set by you via the PM Hours parameter (126). This value can be reset by you after an event via the meter reset parameter (16).	R	
22	Starts to PM	—	0/50000	0	Displays the estimated number of starts to a PM event if enabled. The scheduled number of starts for a PM event is set by you via the PM Starts parameter (127). This value can be reset by you after an event via the meter reset parameter (16).	R	
23	Total Starts	—	0/30000	0	Displays the total number of SMC starts. The SMC keeps a Start Counter which is incremented each time the SMC is started. This parameter cannot be reset by the customer and leaves the factory with a value of 0.	R	
24	Start Time	1	Secs	0/1000	0	R	
25		2					Displays the measured start time of the 2nd previous start.
26		3					Displays the measured start time of the 3rd previous start.
27		4					Displays the measured start time of the 4th previous start.
28		5					Displays the measured start time of the 5th previous start.
29	Peak Current	1	Amps	0/150000	0	R	
30		2					Displays the measured peak current of the 2nd previous start.
31		3					Displays the measured peak current of the 3rd previous start.
32		4					Displays the measured peak current of the 4th previous start.
33		5					Displays the measured peak current of the 5th previous start.
34	Motor Speed	%	0/100	0	Displays the estimated motor speed during starting and stopping. This parameter is only valid when using the linear speed starting or linear speed stopping modes.	R	
35	THD ⁽¹⁾ Va	%	0/1000.0	0	Measures the THD of the applied Phase A line voltage.	R	
36	THD Vb				Measures the THD of the applied Phase B line voltage.		
37	THD Vc				Measures the THD of the applied Phase C line voltage.		
38	THD Vave				Displays the calculated average of the three voltage THD measurements.		
39	THD ⁽¹⁾ Ia	%	0/1000.0	0	Measures the THD of the applied Phase A current.	R	
40	THD Ib				Measures the THD of the applied Phase B current.		
41	THD Ic				Measures the THD of the applied Phase C current.		
42	THD Iave				Displays the calculated average of the three current THD measurements.		

(1) THD = A Power Quality measurement that lets you measure total harmonic distortion levels.

Table 134 - Parameter 43...49

No.	Name	Units	Min./Max. Values	Default Value	Enum Text [Default]	Description	Read/Write Access
43	Product Status	—	0/65535	0	—	The product Logic Status is made available to all DPI devices and is also available as a bit enumerated parameter "Product Status". The bits in this parameter correspond with the bits in the Product Logic Status defined for DPI.	R
					bit 0 = Enabled/Ready	1 – Ready 0 – Not Ready	
					bit 1 = Running	1 – Power Applied to Motor (Gating SCRs or Bypass closed) 0 – Power NOT Applied to Motor	
					bit 2 = Phasing	1 – ABC Phasing 0 – CBA Phasing	
					bit 3 = Phasing Active	1 – 3-phase is valid 0 – No valid 3-phase detected	
					bit 4 = Starting (Accel)	1 – Performing a Start Maneuver (slow speed not included) 0 – Not Performing a Start Maneuver	
					bit 5 = Stopping (Decel)	1 – Performing a Stop Maneuver (coast to stop not included) 0 – Not Performing a Stop Maneuver	
					bit 6 = Alarm	1 – Alarm Present 0 – No Alarm Present	
					bit 7 = Fault	1 – Fault Condition Exists and hasn't been cleared 0 – No Fault Condition	
					bit 8 = At Speed	1 – Full Voltage Applied (Bypass or full SCR conduction) 0 – Not Full Voltage Applied	
					bit 9 = Start/Isolate	1 – Start/Isolate Contactor Enabled 0 – Start/Isolate Contactor Disabled	
					bit 10 = Bypass	1 – Bypass Contactor Enabled 0 – Bypass Contactor Disabled	
					bit 11 = Ready	1 indicates that the SMC is ready to accept a Start command. The device is not faulted or in the process of stopping, starting or jogging.	
					bit 12 - 13 = Reserved	Always 0.	
bit 14 = Input #1	Control Module Input #1 Status. 1 = Input Closed.						
bit 15 = Input #2	Control Module Input #2 Status. 1 = Input Closed.						
44	Motor Config	—	0/2	2	Line Delta [Auto]	Lets you select the type of motor connection the SMC-50 controller is being applied to, 'Line' or 'Delta'. If set to 'Auto Config', the SMC-50 controller determines the motor connection.	R/W
45	Motor Connection	—	0/1	0	[Line] Delta	Displays the type of motor connection the SMC-50 controller is configured to operate with.	R
46	Line Voltage	Volt	0/700	480	NA	The Line voltage applied to the SMC L1, L2, L3 terminals.	R/W
47	Rated Torque	N•m	0/10000	10	NA	Lets you enter the rated torque of the motor as read from the motor specifications (typically nameplate). This is required for proper torque mode starts and stops.	R/W
48	Rated Speed	rpm	0/5	3	750, 900, 1500, [1800], 3500, 3600	Lets you enter the rated motor speed as read from the motor specifications (typically nameplate). Required for proper torque mode starts and stops.	R/W
49	Starting Mode	—	0/5	2		Used to program the SMC controller for the type of starting mode that best fits the application.	R/W
					Full Voltage	Apply full voltage to the motor at start.	
					Current Limit	Apply limited current for a programmed period of time.	
					[Soft Start]	Slowly increase current to load over a programmed period of time.	
					Linear Speed	Increase current to cause a linear acceleration of the motor.	
					Torque Ramp	Slowly increase torque generated by motor over fixed period of time.	
Pump Start	Special starting algorithm for pump applications.						

Table 135 - Parameter 50...57

No.	Name	Units	Min./Max. Values	Default Value	Enum Text [Default]	Description	Read/Write Access
50	Ramp Time	Sec	0.0/1000.0	10.0	NA	Lets you configure the time period during which the controller ramps the output voltage.	R/W
51	Initial Torque	%LRT	0/90	70	NA	Establishes and adjusts initial reduced voltage output level for the voltage ramp.	R/W
52	Max. Torque	%	0/300	250	NA	Lets you configure the max. torque limit of a torque ramp during a torque start operation.	R/W
53	Cur Limit Level	%FLC	50/600	350	NA	The current limit level that is applied for the ramp time selected.	R/W
54	Kickstart Time	SEC	0.0/2.0	0.0	NA	A boost of current is applied to the motor for this programmed time.	R/W
55	Kickstart Level	%LRT	0/90	0	NA	Lets you adjust the amount of current boost applied to the motor during the kickstart period.	R/W
56	Input 1	—	0/14	4	—	Lets you select the operation of Terminal 11, Input 1 on the control module.	R/W
					Disable	Disable the input - ignores any assertion to Input 1, Terminal 11.	
					Start	Initiates a start as set up by the start parameters at Input 1, Terminal 11 (High).	
					Coast	Initiates a coast stop.- no current to motor at Input 1, Terminal 11 (Low).	
					Stop Option	Initiates a stop maneuver as set up by the stopping parameters at Input 1 (Low).	
					[Start/Coast]	if Input 1 = 0 - Stops motor 1 - Initiates a start as set up by the start parameters	
					Start/Stop	if Input 1 = 0- Initiates a stop maneuver as set up by stopping parameters 1 - Initiates a start as set up by the start parameters	
					Slow Speed 1	Runs motor in slow speed mode 1 as set up by slow speed 1 parameters (High).	
					Slow Speed 2	Runs motor in slow speed mode 2 as set up by slow speed 2 parameters (High).	
					Dual Ramp	if Input 1 = 0 - Use starting mode 1 1 - Use starting mode 2	
					OL Select	if Input 1 = 0 - Use Motor Overload Class 1 1 - Use Motor Overload Class 2	
					Fault	A fault condition forced if Input 1= 1.	
					Fault NC	A fault condition forced if Input 1 = 0.	
					Clear Fault	Clear a fault from input 1 Terminal 11 (High).	
					Emerg Run	Allows motor to run in emergency run mode if asserted from Input 1, Terminal 11 - does not start motor (High).	
Motor Heater	Run motor heating algorithm if asserted from Input 1, Terminal 11 (High).						
57	Input 2	—	0/14	0	—	Lets you select the operation of Terminal 10, Option Input 2, on the control module.	R/W
					[Disable]	Disable the input - ignores any assertion to Input 2 Terminal 10.	
					Start	Initiate a start as set up by the start parameters at Input 2 Terminal 10 (High).	
					Coast	Initiates a coast stop.- no current to motor at Input 2 Terminal 10 (Low).	
					Stop Option	Initiates a stop maneuver as set up by the stopping parameters at Input 2 (Low).	
					Start/Coast	If Input 2= 0 - Stops motor 1 - Initiate a start as set up by the start parameters	
					Start/Stop	If Input 2 = 0- Initiate a stop maneuver as set up by stopping parameters 1 - Initiate a start as set up by the start parameters	
					Slow Speed 1	Runs motor in slow speed mode 1 as set up by slow speed 1 parameters (High).	
					Slow Speed 2	Runs motor in slow speed mode 2 as set up by slow speed 2 parameters (High).	
					Dual Ramp	If Input 2= 0 - Use Starting Mode 1 1 - Use Starting Mode 2	
					OL Select	If Input 2 = 0 - User Motor Overload Class 1 1 - Use Motor Overload Class 2	
					Fault	A fault condition is forced if Input 2= 1.	
					Fault NC	A fault condition is forced if Input 2 = 0.	
					Clear Fault	Clear a fault from Input 2 (High).	
					Emerg Run	Allows motor to run in emergency run mode if asserted on Input 2 - does not start motor (High).	
Motor Heater	Run motor heating algorithm if asserted at Input 2 (High).						

Table 136 - Parameter 58...71

No.	Name	Units	Min./Max. Values	Default Value	Enum Text [Default]	Description	Read/Write Access
58	Starting Mode 2	—	0/5	2	—	Lets you program an alternate starting mode for the SMC-50 controller that suits the application.	R/W
					Full Voltage	Apply full voltage to the motor at start.	
					Current Limit	Apply limited current for a programmed period of time.	
					[Soft Start]	Slowly increase current to load over a programmed period of time.	
					Linear Speed	Increase current to cause a linear acceleration of the motor.	
					Torque Ramp	Slowly increase torque generated by the motor over a fixed period of time.	
Pump Start	Special starting algorithm for pump applications.						
59	Ramp Time 2	Sec	0.0/1000.0	10.0	NA	Lets you set an alternate time period during which the controller ramps the output voltage.	R/W
60	Initial Torque 2	%LRT	0/90	70	NA	Lets you set an alternate initial reduced voltage output level for the voltage ramp.	R/W
61	Max. Torque 2	%	0/300	250	NA	Lets you set a alternate maximum torque limit of a torque ramp during a torque start operation.	R/W
62	Cur Limit Level 2	%FLC	50/600	350	NA	Lets you set an alternate current limit level that is applied for the ramp time selected.	R/W
63	Kickstart Time 2	Sec	0/2	0	NA	Lets you set an alternate boost current to be applied to the motor for the programmed time.	R/W
64	Kickstart Level 2	%LRT	0/90	0	NA	Lets you set an alternate adjustment of the amount of current applied to the motor during the kickstart period.	R/W
65	Stop Mode	—	0/5	0	—	Lets you program the SMC-50 controller for the type of stopping that best suits the application.	R/W
					[Coast]	Coast-to-Rest	
					Soft Stop	Slowly reduces current by reducing voltage applied to the motor over a programmed period of time.	
					Linear Speed	Stops the motor following a linear speed ramp over a programmed period of time.	
					Pump Stop	Slowly reduces current by reducing voltage applied to the motor using the pump stop algorithm over a programmed period of time.	
					SMB	Brakes the motor to a stop using an SCR firing pattern to create current flow to brake the motor per the configuration of the braking parameters.	
External Brake	Closes an external contactor to apply braking current to the motor.						
66	Stop Time	Sec	0/999	0	NA	Sets the time period for which the controller ramps the voltage during a stopping maneuver.	R/W
67	Backspin Timer	Sec	0/999	0	NA	Avoids starting into a backspin condition. The timer begins counting after a stop is completed (coast, stop maneuver, fault etc). All start inputs is ignored until the backspin timer has timed out.	R/W
68	Pump Pedestal	%	0/50	0	NA	Lets you adjust the pump algorithm slightly for different applications. Typically, this is used to shorten the ramp time before the SMC-50 controller starts to get aggressive in its pump stopping maneuver.	R/W
69	Braking Current	%FLC	0/400	0	NA	Lets you program the intensity of the braking current applied to the motor.	R/W
70	Brake Load Type	—	0/3	0		Identifies the load type to enable appropriate braking algorithms.	R/W
					Standard	—	
					High Inertia	—	
					High Friction	—	
Ramp 89	Special braking mode that reduces braking torques.						
71	High Eff Brake	%	0/99	0	NA	Adds additional time to a braking sequence after the SMC-50 controller detects a zero speed condition that indicates the end of the braking sequence. Can adjust if additional time is needed to stop the load.	R/W

Table 137 - Parameter 72...94

ENUM Text is not applicable for the parameters in this table.

No.	Name	Units	Min./Max. Values	Default Value	Description	Read/Write Access
72	Slow Speed 1	%	-15/15	10	Lets you program slow speed 1 that best suits the application.	R/W
73	Slow Brake Cur	%FLC	0/350	0	Provides braking from slow speed. If set to 0, no braking is provided. Any other setting results in motor braking when the slow speed operation is terminated.	R/W
75	Overload Class	—	5/30	10	Sets the desired trip class of internal solid state overload. Overload fault and alarms are enabled and disabled in the Starter Fault En and Starter Alarm parameters.	R/W
76	Overload Class 2	—	5/30	10	Lets you set the internal solid state overload to an alternate trip class. This Trip Class is used when an input (configured as overload select) is asserted.	R/W
77	Service Factor	—	0.01/1.990	1.15	Parameter to enter the value of the motor's service factor from the nameplate.	R/W
78	Motor FLC	Amps	1.0/2200.0	1.0	Parameter to enter the Full Load Current (FLC) value from the motor's nameplate.	R/W
79	Motor FLC 2	Amps	1.0 . . 2200.0	1.0	Second motor FLC setting to be used when Overload #2 is selected using the "Overload 2" input.	R/W
80	OL Reset Level	%MTU	1/99	75	When the level of Motor Thermal Usage (MTU) drops below this limit after an OL fault, an overload reset can occur. If restart is enabled, the motor overload automatically resets when the MTU drops below this level	R/W
81	OL Shunt Time	Secs	0/999	0	Disables the overload from incrementing MTU for the selected time period after a start or stop command is initiated.	R/W
82	OL Inhibit Time	Secs	0/999	0	Disables the overload from tripping during slow speed and stopping maneuvers. The MTU. Therm Usage continues to increment during these maneuvers.	R/W
83	Overload A Level	%MTU	0/100	90	The MTU level that sets off an alarm when exceeded. The Overload bit the Motor Alarm En parameter must be set to signal an alarm.	R/W
84	Locked Rtr F Lvl	%FLC	400/1000	600	The peak phase current to the load that, if exceeded for the time period defined in Locked Rtr Delay, signals a fault. The Locked Rotor bit in the Motor Fault En parameter must be set to signal a fault.	R/W
85	Locked Rtr F Dly	Secs	0.1/100.0	0.1	The time period that the peak phase current exceeds the Locked Rtr F Level to signal a fault. The Locked Rotor bit in the Motor Fault En parameter must be set to signal a fault.	R/W
86	Underload F Lvl	%FLC	0/99	0	If phase current drops below this level for the period of time set in Underload F Dly parameter, an Underload Fault is signaled. The Underload bit in the Motor Fault En parameter must be set to signal a fault.	R/W
87	Underload F Dly	Secs	0.1/99.0	0.1	The time period that the phase current must be below the level set in the Underload F Level parameter before a underload fault is signaled. The Underload bit in the Motor Fault En parameter must be set to signal a fault.	R/W
88	Underload A Lvl	%FLC	0/99	0	If phase current drops below this level for the period of time set in Underload A Dly parameter, an Underload Alarm is signaled. The Underload bit in the Motor Alarm En parameter must be set to signal a alarm.	R/W
89	Underload A Dly	Secs	0.1/99.0	0.1	The time period that the phase current must be below the level set in the Underload A Level parameter before an Underload Alarm is signaled. The Underload bit in the Motor Alarm En parameter must be set to signal a alarm.	R/W
90	MWatts Ov F Lvl	MW	0.000/1000.00	0.000	If the Real Power exceeds this level for the time period set in MWatts Ov F Dly parameter, an MWatts Ov fault is signaled. The MWatts Ov bit in the Motor Fault En parameter must be set to signal a fault.	R/W
91	MWatts Ov F Dly	Secs	0.1/99.0	0.1	The time period that Real Power must exceed MWatts Ov F Lvl to signal a fault. The MWatts Ov bit in the Motor Fault En parameter must be set to signal fault.	R/W
92	MWatts Ov A Lvl	MW	0.000/1000.00	0.000	If the Real Power exceeds this level for the time period set in MWatts Ov A Dly parameter, a MWatts Ov Alarm is signaled. The MWatts Ov bit in the Motor Alarm En parameter must be set to signal an alarm.	R/W
93	MWatts Ov A Dly	Secs	0.1/99.0	0.1	The time period that Real Power must exceed MWatts Ov A Lvl to signal an alarm. The MWatts Ov bit in the Motor alarm En parameter must be set to signal an alarm.	R/W
94	MWatts Un F Lvl	MW	0.000/1000.00	0.000	If the Real Power drops below this level for the time period set in MWatts Un F Dly parameter, an MWatts Un Fault is signaled. The MWatts Un bit in the Motor Fault En parameter must be set to signal a fault.	R/W

Table 138 - Parameter 95...113

ENUM Text is not applicable for the parameters in this table.

No.	Name	Units	Min./Max. Values	Default Value	Description	Read/Write Access
95	MWatts Un F Dly	Secs	0.1/99.0	0.1	The time period that Real Power must drop below MWatts Un F Lvl to signal a fault. The MWatts Un bit in the Motor Fault En parameter must be set to signal a fault.	R/W
96	MWatts Un A Lvl	MW	0.000/1000.00	0.000	If the Real Power drops below this level for the time period set in MWatts Un A Dly parameter, an MWatts Un Alarm is signaled. The MWatts Un bit in the Motor Alarm En parameter must be set to signal an alarm.	R/W
97	MWatts Un A Dly	Secs	0.1/99.0	0.1	The time period that Real Power must drop below MWatts Un A Level to signal an alarm. The MWatts Un bit in the Motor Alarm En parameter must be set to signal an alarm.	R/W
98	Undervolt F Lvl	%V	0/100	90	If the average three phase line voltage drops below this level for the time period set in the Undervolt F Dly parameter, an Undervolt fault is signaled. The Undervolt bit in the Starter Fault En parameter must be set to signal a fault.	R/W
99	Undervolt F Dly	Secs	0.1/99.0	3.0	The time period that the average three phase voltage must remain below Undervolt F Level to signal a fault. The Undervolt bit in the Starter Fault En parameter must be set to signal a fault.	R/W
100	Undervolt A Lvl	%V	0/100	90	If the average three phase line voltage drops below this level for the time period set in the Undervolt A Dly parameter, an Undervolt Alarm is signaled. The Undervolt bit in the Starter Alarm En parameter must be set to signal an Alarm.	R/W
101	Undervolt A Dly	Secs	0.1/99.0	3.0	The time period that the average three phase voltage must remain below Undervolt A Lvl to signal an Alarm. The Undervolt bit in the Starter Alarm parameter must be set to signal an Alarm.	R/W
102	Overvolt F Lvl	%V	100/199	110	If the average three phase line voltage exceed this level for the time period set in the Overvolt F Dly parameter, an Overvolt fault is signaled. The Overvolt bit in the Starter Fault En parameter must be set to signal a fault.	R/W
103	Overvolt F Dly	Secs	0.1/99.0	3.0	The time period that the average three phase voltage must exceed the Overvolt F Level to signal a fault. The Overvolt bit in the Starter Fault En parameter must be set to signal a fault.	R/W
104	Overvolt A Lvl	%V	100/199	110	If the average three phase line voltage exceed this level for the time period set in the Overvolt A Dly parameter, an Overvolt alarm is signaled. The Overvolt bit in the Starter Alarm parameter must be set to signal an alarm.	R/W
105	Overvolt A Dly	Secs	0.1/99.0	3.0	The time period that the average three phase voltage must exceed the Overvolt A Level to signal an alarm. The Overvolt bit in the Starter alarm En parameter must be set to signal a alarm.	R/W
106	Volt Unbal F Lvl	%	1/25	15	If the line-to-line voltage imbalance condition exceeds the Volt Unbal F Lvl for the period set in Volt Unbal F Dly, a fault is signaled. The Volt Unbal bit must be set in the Starter Fault En parameter to signal a fault. See manual for details on imbalance calculations.	R/W
107	Volt Unbal F Dly	Secs	0.1/99.0	3.0	The time period that the voltage imbalance exceeds the Volt Unbal F Lvl to signal a fault. The Volt Unbal bit in the Starter Fault En parameter must be set to signal a fault.	R/W
108	Volt Unbal A Lvl	%	1/25	15	If the line-to-line voltage imbalance condition exceeds the Volt Unbal A Lvl for the time period set in Volt Unbal A Dly, an alarm is signalled. The Volt Unbal bit must be set in the Starter Alarm parameter to signal a alarm. See manual for details on imbalance calculations.	R/W
109	Volt Unbal A Dly	Secs	0.1/99.0	3.0	The time period that the voltage imbalance exceeds the Volt Unbal A Level to signal a alarm. The Volt Unbal bit in the Starter Alarm parameter must be set to signal a alarm.	R/W
110	Cur Imbal F Lvl	%	1/25	15	If the line-to-line current imbalance condition exceeds the Cur Imbal F Lvl for the time period set in Cur Imbal F Dly, a fault is signalled. The Cur Imbal bit must be set in the Motor Fault En parameter to signal a fault.	R/W
111	Cur Imbal F Dly	Secs	0.1/99.0	3.0	The time period that the current imbalance exceeds the Cur Imbal F Lvl to signal a fault. The Cur Imbal bit in the Motor Fault En parameter must be set to signal a fault.	R/W
112	Cur Imbal A Lvl	%	1/25	15	If the line-to-line current imbalance condition exceeds the Cur Imbal A Lvl for the time period set in Cur Imbal A Dly, an alarm is signaled. The Cur Imbal bit must be set in the Motor Alarm En parameter to signal a Alarm.	R/W
113	Cur Imbal A Dly	Secs	0.1/99.0	3.0	The time period that the current imbalance exceeds the Cur Imbal A Lvl to signal an alarm. The Cur Imbal bit in the Motor Alarm En parameter must be set to signal an alarm.	R/W

Table 139 - Parameter 114...134

ENUM Text is not applicable for the parameters in this table.

No.	Name	Units	Min./Max. Values	Default Value	Description	Read/Write Access
114	Jam F Lvl	%FLC	0/1000	1000	If the peak phase current exceeds the Jam F Lvl for the time period set in Jam F Dly, a fault is signaled. The Jam bit must be set in the Motor Fault En parameter to signal a fault.	R/W
115	Jam F Dly	Secs	0.1/99.0	0.1	The time period that the peak phase current exceeds the Jam F Lvl to signal a fault. The Jam bit in the Motor fault En parameter must be set to signal a fault.	R/W
116	Jam A Lvl	%FLC	0/1000	1000	If the peak phase current exceeds the Jam A Lvl for the time period set in Jam A Dly, an alarm is signaled. The Jam bit must be set in the Motor Alarm En parameter to signal an alarm.	R/W
117	Jam A Dly	Secs	0.1/99.0	0.1	The time period that the peak phase current exceeds the Jam A level to signal an alarm. The Jam bit in the Motor Alarm En parameter must be set to signal an alarm.	R/W
118	THD V F Lvl	%	0/1000	1000	If the average total harmonic distortion (THD) on the line voltage exceeds the THD V F Lvl for the time period set in THD V F Dly, a fault is signaled. The THD V bit must be set in the Starter Fault En parameter to signal a fault.	R/W
119	THD V F Dly	Secs	0.1/99.0	0.1	The time period that the average THD on the line voltage exceeds the THD V F Lvl to signal a fault. The THD V bit in the Starter Fault En parameter must be set to signal a fault.	R/W
120	THD V A Lvl	%	0/1000	1000	If the average THD on the line voltage exceeds the THD V A Lvl for the time period set in THD V Dly, an alarm is signaled. The THD V bit must be set in the Starter Alarm parameter to signal an alarm.	R/W
121	THD V A Dly	Secs	0.1/99.0	0.1	The time period that the average THD on the line voltage exceeds the THD V A Lvl to signal an alarm. The THD V bit in the Starter Alarm parameter must be set to signal an alarm.	R/W
122	THD I F Lvl	%	0/1000	1000	If the average THD on the phase current exceeds the THD I F Lvl for the period set in THD I F Dly, a fault is signaled. The THD I bit must be set in the Motor Fault En parameter to signal a fault.	R/W
123	THD I F Dly	Secs	0.1/99.0	0.1	The time period that the average THD on the phase current exceeds the THD I F Lvl to signal a fault. The THD I bit in the Motor Fault En parameter must be set to signal a fault.	R/W
124	THD I A Lvl	%	0/1000	1000	If the average THD on the phase current exceeds the THD I A Lvl for the time period set in THD I A Dly, an alarm is signaled. The THD I bit must be set in the Motor Alarm En parameter to signal an alarm.	R/W
125	THD I A Dly	Secs	0.1/99.0	0.1	The time period that the average THD on the phase current exceeds the THD I A Lvl to signal an alarm. The THD I bit in the Motor Alarm En parameter must be set to signal an alarm.	R/W
126	PM Hours	Hrs	1/100	1000	You can set this counter to generate an alarm or fault to signal a need for preventive maintenance. The Hours to PM parameter is initialized to this value and counts down when the motor is running.	R/W
127	PM Starts	—	1/50000	100	You can set this counter to generate an alarm or fault to signal a need for preventive maintenance. The Starts to PM parameter is initialized to this value and counts down each time the motor is started.	R/W
128	Starts per Hour	—	1/99	99	You can program the maximum number of starts within a sliding one-hour window. Once the number of starts per hour is reached any additional starts causes a fault.	R/W
129	Freq High F Lvl	Hz	45/66	63	The highest line voltage frequency that can be applied to the SMC-50 controller before causing a Freq High F Lvl fault. The Freq High bit in the Starter Fault En parameter must be set to signal a fault.	R/W
130	Freq Low F Lvl	Hz	45/66	47	The lowest line voltage frequency that can be applied to the SMC-50 controller before causing a Freq Low F Lvl fault. The Freq Low bit in the Starter Fault En parameter must be set to signal a fault.	R/W
131	Freq High A Lvl	Hz	45/66	63	The highest line voltage frequency that can be applied to the SMC-50 controller before causing a Freq High F Lvl alarm. The Freq High bit in the Starter Alarm parameter must be set to signal an alarm.	R/W
132	Freq Low A Lvl	Hz	45/66	47	The lowest line voltage frequency that can be applied to the SMC-50 controller before causing a Freq Low F Lvl alarm. The Freq Low bit in the Starter Alarm parameter must be set to signal an alarm.	R/W
133	Restart Attempts	—	0/5	0	Lets you enable the SMC-50 controller to auto-restart for up-to five attempts after a thyristor has failed to fire and results in an open gate fault trip.	R/W
134	Restart Dly	Secs	0/60	0	Provides a delay time prior to the SMC-50 controller's attempt to restart the motor after a fault.	R/W

Table 140 - Parameter 135...148

No.	Name	Units	Min./Max. Values	Default Value	Enum Text [Default]	Description	Read/Write Access
135	Strtr Restart En	—	0	0	Volt Unbal	Lets you select which type of fault that the SMC-50 controller can try to restart from once the restart delay period has expired. To enable a restart from a fault, the function must be selected (1). Restart Attempts, Parameter 133, and Restart Delay, Parameter 134, must be configured.	R/W
					Overvoltage		
					Undervoltage		
					Phase Rev		
					Line Loss		
					Open Gate		
					Config Change		
					Freq		
THD V							
			Future	Future	Future		
136	Starter Fault En	—	0	0	Volt Unbal	Lets you enable faults associated with the control module. The bit for a fault must be set (1) for the fault to be asserted.	R/W
			0	0	Overvoltage		
			0	0	Undervoltage		
			0	0	Phase Rev		
			1	1	Line Loss		
			1	1	Open Gate		
			0	0	Config Change		
			0	0	Freq		
0	0	THD V					
137	Starter Alarm En	—	0	0	Volt Unbal	Lets you enable alarms associated with the control module. The bit for an alarm must be set (1) for the alarm to be asserted.	R/W
					Overvoltage		
					Undervoltage		
					Phase Rev		
					Line Loss		
					Open Gate		
					Config Change		
					Freq		
THD V							
138	Fault	1	0/1000	0	NA	First entry in the fault buffer and is the most recent fault to have occurred.	R/W
139		2				Second entry in the fault buffer.	
140		3				Third entry in the fault buffer.	
141		4				Fourth entry in the fault buffer.	
142		5				Fifth entry in the fault buffer. The oldest fault displayed in the fault buffer.	
143	Alarm	1	0/1000	0	NA	First entry in the alarm buffer and is the most recent alarm to have occurred.	R/W
144		2				Second entry in the alarm buffer.	
145		3				Third entry in the alarm buffer.	
146		4				Fourth entry in the alarm buffer.	
147		5				Fifth entry in the alarm buffer. There can be up to 100 events stored in the alarm buffer. To see the whole buffer, go the diagnostics tab on the HIM or Connected Components Workbench software.	
148	Logic Mask	—	0/65535	0	NA	The bits in this parameter allow you to enable (bit=1) or disable (bit=0) which DPI ports the SMC-50 controller accepts Start and Maneuver commands from. Coast Stop commands are always accepted from any port. bit 1 = port 1 (On board HIM) [Default=0] bit 2 = port 2(DPI port on control module) [Default=0] bit 3 = port 3(DPI port on control module with splitter) [Default=0] bit 4 = port 4(Internal Comm module) [Default=0] bit 5-13 = unused bit 14 = port 14 [DeviceLogix engine] bit 15 = unused	R/W

Table 141 - Parameter 149...171

ENUM Text is not applicable for the parameters in this table.

No.	Name	Units	Min./Max. Values	Default Value	Description	Read/Write Access			
149	Logic Mask Act	—	0/65535	0	Displays which DPI port the SMC-50 controller accepts a start command from. It may be different from the Logic Mask set by the local user if someone changes it over the network. bit 1 = port 1 (on board HIM) bit 2 = port 2 (DPI port on control module) bit 3 = port 3 (DPI port on control module with splitter) bit 4 = port 4 (Internal Comm module) bit 5-15 = reserved	R			
150	Write Mask Cfg	—	0/65535	7FFF	This bits in this parameter allow you to enable (bit=1) or disable (Bit=0) which DPI ports the SMC-50 controller accepts write commands from. Only selected ports can modify parameters. bit 1 = port 1 (on board HIM) [Default=1] bit 2 = port 2 (DPI port on control module) [Default=1] bit 3 = port 3 (DPI port on control module with splitter) [Default=1] bit 4 = port 4 (Internal Comm module) [Default=1] bit 5-15 = reserved [Default=0]	R/W			
151	Write Mask Act	—	0/65535	0	Displays which DPI ports the SMC accepts write commands from that can change parameters. It may be different from the Write Mask Cfg parameter setup by the local user if someone changes it over the network. bit 1 = port 1 (on board HIM) bit 2 = port 2 (DPI port on control module) bit 3 = port 3 (DPI port on control module with splitter) bit 4 = port 4 (Internal Comm module) bit 5-15 = reserved	R			
152	Port Mask Act	—	0/65535	0	Displays which DPI ports are active on the control module and accepts operational commands from. bit 1 = port 1 (on board HIM) bit 2 = port 2 (DPI port on control module) bit 3 = port 3 (DPI port on control module with splitter) bit 4 = port 4 (Internal Comm module) bit 5-15 = reserved	R			
153	Data In	A1	—	0/159999	0	This is the channel	A1	In Datalink index, holding the parameter number of the parameter that is written to during Datalink communications. A value of 0 indicates that it is disabled.	R/W
154		A2					A2		
155		B1					B1		
156		B2					B2		
157		C1					C1		
158		C2					C2		
159		D1					D1		
160		D2					D2		
161	Data Out	A1	—	0/159999	0	This is the channel	A1	Out Datalink index, holding the parameter number of the parameter that is read from during Datalink communications. A value of 0 indicates that it is disabled.	R/W
162		A2					A2		
163		B1					B1		
164		B2					B2		
165		C1					C1		
166		C2					C2		
167		D1					D1		
168		D2					D2		
169	Voltage Ratio	—	1/32767	3079	Allow OEMs to fine-tune their voltage dividers. This is a Medium Voltage specific parameter and has no function at 690 volts and below.	R/W			
170	User CT Ratio	—	10/500	100	Lets you achieve proper current ratio for FLC ratings when using external CTs. This is a MV specific parameter and has no function at 690 volts and below.	R/W			
171	Factory CT Ratio	—	1/15000	50	Set at the factory to achieve proper current ratio for FLC ratings when using external CTs. This is a MV specific parameter and has no function at 690 volts and below.	R/W			

Table 142 - Parameter 172...177

No.	Name	Units	Min./Max. Values	Default Value	Enum Text [Default]	Description	Read/Write Access
172	Aux1 Config	—	0/12	0	—	Lets you configure the functionality of the Aux1 relay output on the control module based on the following selections.	R/W
					[Normal]	Aux 1 closes when start command asserted and opens when motor stops [Default].	
					UTS (Up-To-Speed)	Aux 1 closes when motor reaches up to speed and opens when motor is not at speed.	
					Fault	Aux1 closes when the SMC-50 controller enters a fault state and opens when the fault is cleared.	
					Alarm	Aux1 closes when the SMC-50 controller detects an alarm condition and opens when alarm is cleared.	
					Ext Bypass	Aux1 closes when the SMC-50 controller enters the external bypass mode and opens when it leaves that mode.	
					Ext Brake	Aux 1 closes when Ext Braking command is active and opens when it is not active.	
					DeviceLogix	Aux1 is controlled by DeviceLogix program	
					Aux Control	When an auxiliary is configured for Aux Control, a bit within the parameter Aux Control controls the state of that auxiliary.	
					Network 1	With an auxiliary configured as Network 1, it is controlled over the Local Area Network (LAN) as Relay 1.	
					Network 2	With an auxiliary configured as Network 2 it is controlled over the LAN as Relay 2.	
					Network 3	With an auxiliary configured as Network 3 it is controlled over the LAN as Relay 3.	
					Network 4	With an auxiliary configured as Network 4 it is controlled over the LAN as Relay 4.	
Fan Control	Used to control fans.Fan is turned on when the motor is running or the estimated SCR temperature is above 50°C						
173	Aux 1 Invert	—	0/1	0	—	Lets you invert the logic of the Aux 1 output. When disabled, it is a normally open relay output contact when de-energized. By enabling the invert function, the relay contact becomes a normally closed contact when de-energized.	R/W
					Disable	Aux 1 relay output not inverted [Default] (N.O.).	
					Enable	Aux 1 relay output inverted (N.C.) (N.C. is electrically held).	
174	Aux1 On Delay	Secs	0.0/10.0	0.0	NA	A time delay in activating the Aux1 relay contact can be programmed.	R/W
175	Aux1 Off Delay	Secs	0.0/10.0	0.0	NA	A time delay in de-activating the Aux1 relay contact can be programmed.	R/W
176	Aux2 Config	—	0/12	0	—	Lets you configure the functionality of the Aux1 relay output on the control module based on the following selections.	R/W
					[Normal]	Aux 2 closes when start command asserted and opens when motor stops [Default].	
					UTS	Aux 2 closes when motor reaches up to speed and opens when motor is not at speed.	
					Fault	Aux2 closes when the SMC-50 controller enters a fault state and opens when the fault is cleared.	
					Alarm	Aux2 closes when the SMC-50 controller detects an alarm condition and opens when alarm is cleared.	
					Ext Bypass	Aux2 closes when the SMC-50 controller enters the external bypass mode and opens when it leaves that mode.	
					Ext Brake	Aux2 closes when Ext Braking command is active and opens when it is not active.	
					DeviceLogix	Aux2 is controlled by DeviceLogix program	
					Aux Control	When an auxiliary is configured for Aux Control, a bit within the parameter Aux Control controls the state of that auxiliary.	
					Network 1	With an auxiliary configured as Network 1, it is controlled over the Local Area Network (LAN) as Relay 1.	
					Network 2	With an auxiliary configured as Network 2 it is controlled over the LAN as Relay 2.	
					Network 3	With an auxiliary configured as Network 3 it is controlled over the LAN as Relay 3.	
					Network 4	With an auxiliary configured as Network 4 it is controlled over the LAN as Relay 4.	
Fan Control	Used to control fans.Fan is turned on when the motor is running or the estimated SCR temperature is above 50°C						
177	Aux 2 Invert	—	0/1	0	—	Lets you invert the logic of the Aux2 output. When disabled, it is a normally open relay output contact when de-energized. By enabling the invert function, the relay contact becomes a normally closed contact when de-energized.	R/W
					Disable	Aux2 relay output not inverted [Default] (N.O.).	
					Enable	Aux2 relay output inverted (N.C.) (N.C. is electrically held.)	

Table 143 - Parameter 178...185

No.	Name	Units	Min./Max. Values	Default Value	Enum Text [Default]	Description	Read/Write Access
178	Aux2 On Delay	Secs	0.0/10.0	0.0	NA	A time delay in activating the Aux2 relay contact can be programmed.	R/W
179	Aux2 Off Delay	Secs	0.0/10.0	0.0	NA	A time delay in de-activating the Aux2 relay contact can be programmed.	R/W
180	Aux Control	—	0	0	—	When an Auxiliary Relay output is configured for "Aux Control" a bit within this parameter controls the state of the auxiliary.	R/W
					Aux 1	Bit 0 - Control Module Aux Relay 1	
					Aux 2	Bit 1 - Control Module Aux Relay 2	
					Aux 7-1	Bit 2 - Expansion Port 7 Aux Relay 1	
					Aux 7-2	Bit 3 - Expansion Port 7 Aux Relay 2	
					Aux 7-3	Bit 4 - Expansion Port 7 Aux Relay 3	
					Aux 7-4	Bit 5 - Expansion Port 7 Aux Relay 4	
					Aux 8-1	Bit 6 - Expansion Port 8 Aux Relay 1	
					Aux 8-2	Bit 7 - Expansion Port 8 Aux Relay 2	
					Aux 8-3	Bit 8 - Expansion Port 8 Aux Relay 3	
					Aux 8-4	Bit 9 - Expansion Port 8 Aux Relay 4	
					Aux 9-1	Bit 10 - Expansion Port 9 Aux Relay 1	
					Aux 9-2	Bit 11 - Expansion Port 9 Aux Relay 2	
					Aux 9-3	Bit 12 - Expansion Port 9 Aux Relay 3	
					Aux 9-4	Bit 13 - Expansion Port 9 Aux Relay 4	
		Bit 14 - Reserved					
		Bit 15 - Reserved					
181	Language	—	0	0	[English]	Lets you configure the language that is displayed for any interface device. The selected language is the same for all devices connected to the SMC-50 controller.	R/W
					French		
					Spanish		
					Italian		
					German		
					Portuguese		
					Mandrin		
182	Start Delay	Secs	0/30	0	NA	The time between asserting a start command with valid 3-phase applied and the SMC-50 controller starting the motor can be delayed by setting the "Start Delay". If a stop is asserted during the delay period, the start is cancelled.	R/W
183	Timed Start	—	0/1	0	—	This parameter is used to force the starting profile to complete its entire time ramp period. This ability can help to avoid conditions where an up-to-speed is sensed before the motor is actually up to speed.	R/W
					Disable	Complete starting mode when up-to-speed detected.	
					Enable	Complete starting mode when ramp time expires.	
184	V Shutoff Level	%	0/100	25	NA	Lets you manually adjust the threshold for the controller's voltage (notch) shutoff detection level. Because this parameter has the potential to modify the SCR operational control scheme, it is important that any change made be in small (several percent) increments. Do NOT disable (0) this parameter and Parameter 185 (I Shutoff Level) at the same time or SCR firing (motor control) instability can occur. Contact Rockwell Automation Technical Support for assistance. When running high-efficiency motors with Energy Saver, this value may need to be adjusted downward.	R/W
185	I Shutoff Level	%	0/37	0	NA	Lets you adjust the level at which the SMC-50 controller expects to see current or the level of current which the SMC-50 controller determines the SCR has turned off. A common reason for increasing this value is to compensate for the inability of the control to sense a voltage notch due to significant LINE voltage noise or LINE distortion. Because this parameter has the potential to modify the SCR operational control scheme, it is important that any change made is done in small (several percent) increments. Do NOT disable (0) this parameter and Parameter 184 (V Shutoff Level) at the same time or SCR firing (motor control) instability can occur. Contact Rockwell Automation Technical Support for assistance.	R/W

Table 144 - Parameter 186...204

No.	Name	Units	Min./Max. Values	Default Value	Enum Text [Default]	Description	Read/Write Access
186	UTS Level	%	0/100	75	NA	The SMC-50 controller can determine if the motor is up-to-speed (UTS). If the SMC-50 controller encounters a problem detecting motor UTS, this parameter can be modified by you to compensate. If the SMC-50 controller is detecting the UTS condition to soon (for example, abrupt speed change), this number should be increased (this typically occurs on high efficiency motors). If the SMC-50 controller is detecting the UTS condition to late or not at all (display does not indicate At Speed), this number should be lowered. Contact Rockwell Automation Technical Support for assistance.	R/W
187	Stall Level	%	0/100	75	NA	Lets you set the motor winding voltage level (as a percentage of line voltage) at which the SMC-50 controller considers the motor stalled.	R/W
188	Stall Delay	Secs	0.0/30.0	10.0	NA	Lets you configure the time period after the start maneuver start time that the motor has to reach UTS, or else a stall fault occurs.	R/W
189	Stall Position	%	0/100	75	NA	Lets you set the change in the notch position at which the SMC-50 controller considers the motor stalled.	R/W
190	Notch Maximum (Pump Control)	—	50.0/70.0	60.0	NA	Lets you change the maximum notch value during pump stop. ⁽¹⁾	R/W
191	Notch Position	%	40.0/100.0	87.5	NA	Lets you make a manual adjustment to an internal value used for notch control gain, which impacts the SMC-50 controller starting control algorithm. ⁽¹⁾	R/W
192	Bypass Delay	Secs	1/15	1	NA	For applications where fast current spikes or overload conditions (>120% of the controller rating), you can use this parameter to reduce the cycling between SCR and bypass control modes on units with internal bypass. This parameter causes a time delay in closing the bypass contactor.	R/W
193	Energy Saver	—	0.00/1.00	0.00	—	Lets you enable the controller's energy saving control scheme, which opens the "notch" (reduces power applied) to lightly loaded motors thereby reducing the motor terminal voltage and winding losses. This value should be set between the no/light load value and the full/heavy load value of Parameter 17. Set Parameter 193=0 to disable Energy Saver mode.	R/W
194	Forced Tuning	—	0/1	1	—	Enables the controller's tuning algorithms to analyze the load and supply and adjust parameters for easy set up and optimum performance.	R/W
					FALSE	Do not run tuning algorithm (was already run or disabled by user).	
					TRUE	Run tuning algorithm at next start command [Default].	
195	Stator R	Ohms	0.00/50.00	0.00	NA	Lets you read/view the motor stator resistance value that was measured during the tuning process.	R
196	Total R	Ohms	0.00/50.00	0.00	NA	Lets you read/view the motor total load resistance that was measured during the tuning process.	R
197	Coupling Factor	—	0.00/10.00	0.00	NA	This is a coefficient inserted by the controller during the tuning process and viewable by you.	R
198	Inductance	mH	0.00/1000.00	0.00	NA	Lets you read/view the motor inductance that was measured during the tuning process.	R
199	Speed PGain	—	1/10000	1000	NA	Lets you adjust the gain factor used in speed measurement algorithms. ⁽¹⁾	R/W
200	Transient Mag	—	0.00/2.00	0.90			
201	Transient Zero	—	0.00/10.00	5.00			
202	Transient Gain	—	0.00/4.00	1.00			
203	Ping Degree	—	0.0/180.0	50.0	NA	Timing parameter used in speed measurement algorithms. ⁽¹⁾	R/W
204	Pings	—	0/20	2	NA		R/W

(1) This parameter is not typically modified and it is recommended that you contact Rockwell Automation Technical Support for assistance before attempting to do so.

Table 145 - Parameter 205...226

No.	Name	Units	Min./Max. Values	Default Value	Enum Text [Default]	Description	Read/Write Access	
205	Phase Shift	—	-360/360	0	NA	Timing parameters used in speed measurement algorithms. ⁽¹⁾	R/W	
206								0
207								10
208								20
209								30
210								40
211								50
212								60
213								70
214								80
215	90							
216	Board Temp	°C	-25/100	20	NA	Displays the internal temperature of the SMC control module.	R	
217	Exp 7 Config	—	0/5	0	None Input/Output Analog I/O (future) GndF/PTC/CT DIP Switch Seq Start (future)	Displays the type of expansion board plugged into Expansion Port 7.	R	
218	Exp 8 Config	—	0/5	0	None Input/Output Analog I/O (future) GndF/PTC/CT DIP Switch Seq Start (future)	Displays the type of expansion board plugged into Expansion Port 8.	R	
219	Exp 9 Config	—	0/5	0	None Input/Output Analog I/O (future) GndF/PTC/CT DIP Switch Seq Start (future)	Displays the type of expansion board plugged into Expansion Port 9.	R	
220	Heating Time	Secs	0/1000	0	NA	Lets you configure the time period the motor winding heating algorithm is active after asserting the motor heating command.	R/W	
221	Heating Level	%	0/100	0	NA	Lets you configure the amount of current applied during the motor winding heating process.	R/W	
222	Fan Config	—	0/2	0	120V 240V [Auto Detect]	Lets you configure the voltage applied to the internal SMC-50 controller cooling fans. If configured for Auto Detect, the SMC-50 controller uses the control voltage applied to it as the level and configure the fans to work at that level.	R/W	
223	Fan Connection	—	0/1	0	[120V] 240V	Displays the voltage configuration of the fans. If Auto Detect was selected in the Fan Config parameter, this displays the result of the Auto Detect process.	R	
224	Line Frequency	Hz	0/100	0	NA	Displays the line frequency of the three phase voltage applied to the SMC-50 controller at terminals L1, L2, and L3.	R	
225	Freq High F Dly	Secs	0.1/99.0	0.1	NA	Lets you configure the time period that the supplied line voltage frequency must exceed Freq High F Lvl parameter value before causing a Freq High fault. The Freq High bit must be set in the Starter Fault En parameter for the fault to activate.	R	
226	Freq High A Dly	Secs	0.1/99.0	0.1	NA	Lets you configure the time period that the supplied line voltage frequency must exceed Freq High A Lvl parameter value before causing a Freq High alarm. The Freq High bit must be set in the Starter Alarm parameter for the fault to activate.	R	

(1) This parameter is not typically modified and it is recommended that you contact Rockwell Automation Technical Support for assistance before attempting to do so.

Table 147 - Parameter 231...240

No.	Name	Units	Min./Max. Values	Default Value	Enum Text	Description	Read/Write Access
231	Motor Alarm En	—	0 0	0 0	Overload Underload MWatts Over MWatts Under +MVAR Over +MVAR Under -MVAR Over -MVAR Under MVA Under MVA Over Curr Imbal Jam Stall Starts/Hr PM Hours PM Starts Power Qual Open Load THD I Lead PF Un Lead PF Ov Lag PF Un Lag PF Ov Locked Rotor	Lets you enable Motor related alarms that can be detected by the SMC-50 controller. 0 = Fault Disabled 1 = Fault Enabled [All Disabled as Default]	R/W
232	+MVAR Ov F Lvl	MVAR	0.000/1000.000	0.000	NA	Lets you enter a value for the Consumed Reactive Power Over Fault Level (+MVAR Ov F Lvl). If the current actual +MVAR value is greater than the +MVAR Ov F Lvl for a time period greater than that defined by +MVAR Ov F Dly, a +MVAR Ov Fault is signaled. ⁽¹⁾	R/W
233	+MVAR Ov F Dly	Secs	0.1	0.1	NA	Lets you enter a time value for the +MVAR Over Fault delay. If the current actual value of Consumed Reactive Power (+MVAR) is greater than the +MVAR Ov F Lvl for a time period greater than that defined by +MVAR Ov F Dly, a +MVAR Ov Fault is signaled. ⁽¹⁾	R/W
234	+MVAR Ov A Lvl	MVAR	0.000/1000.000	0.000	NA	Lets you enter a value for the Consumed Reactive Power Over Alarm Level (+MVAR Ov A Lvl). If the current actual +MVAR value is greater than the +MVAR Ov A Lvl for a time period greater than that defined by +MVAR Ov A Dly, a +MVAR Ov Alarm is signaled. ⁽¹⁾	R/W
235	+MVAR Ov A Dly	Secs	0.1/99.0	0.1	NA	Lets you enter a time value for the +MVAR Over Alarm Delay (+MVAR Ov A Dly). If the current actual value of Consumed Reactive Power (+MVAR) is greater than the +MVAR Ov A Level for a time period greater than that defined by +MVAR Ov A Dly, a +MVAR Ov Alarm is signaled. ⁽¹⁾	R/W
236	+MVAR Un F Lvl	MVAR	0.000/1000.000	0.000	NA	Lets you enter a value for the Consumed Reactive Power Under Fault Level (+MVAR Un F Lvl). If the current actual +MVAR value is less than the +MVAR Un F Level for a time period greater than that defined by +MVAR Un F Dly, a +MVAR Un Fault is signaled. ⁽¹⁾	R/W
237	+MVAR Un F Dly	Secs	0.1/99.0	0.1	NA	Lets you enter a time value for the +MVAR Under Fault delay. If the Consumed Reactive Power (+MVAR) is less than the +MVAR Un F Level for a time period greater than that defined by +MVAR Un F Dly, a +MVAR Un Fault is signaled. ⁽¹⁾	R/W
238	+MVAR Un A Lvl	MVAR	0.000/1000.000	0.000	NA	Lets you enter a value for the Consumed Reactive Power Under Alarm Level (+MVAR Un A Lvl). If the current actual value of Consumed Reactive Power (+MVAR) is less than the +MVAR Un A Level for a time period greater than that defined by +MVAR Un A Dly a +MVAR Un Alarm is signaled. ⁽¹⁾	R/W
239	+MVAR Un A Dly	Secs	0.1/99.0	0.1	NA	Lets you enter a time value for the +MVAR Under Alarm Delay (+MVAR Un A Dly). If the current actual value of Consumed Reactive Power (+MVAR) is less than the +MVAR Un A Level for a time period greater than that defined by +MVAR Un A Dly, a +MVAR Un Alarm is signaled. ⁽¹⁾	R/W
240	MVA Ov F Lvl	MVA	0.000/1000.000	0.000	NA	Lets you enter a value for the MVA Over Fault Level (MVA Ov F Lvl). If the current actual value of Apparent Power (MVA) is greater than the MVA Ov F Lvl for a time period greater than that defined by MVA Ov F Dly, a MVA Ov Fault is signaled. ⁽¹⁾	R/W

(1) To implement an Alarm or Fault, the appropriate bit in the Motor Fault En, Parameter 230, or Motor Alarm En, Parameter 231, must also be set.

Table 148 - Parameter 241...253

ENUM Text is not applicable for the parameters in this table.

No.	Name	Units	Min./Max. Values	Default Value	Description	Read/Write Access
241	MVA Ov F Dly	Secs	0.1/99.0	0.1	Lets you enter a time value for the Apparent Power Over Fault Delay (MVA Ov F Dly). If the current actual value of Apparent Power (MVA) is greater than the MVA Ov F Lvl for a time period greater than that defined by MVA Ov F Dly, a MVA Ov Fault is signaled. ⁽¹⁾	R/W
242	MVA Ov A Lvl	MVA	0.000/1000.000	0.00	Lets you enter a value for the MVA Over Alarm Level (MVA Ov A Lvl). If the current actual value of the Apparent Power (MVA) is greater than the MVA Ov A Lvl for a time period greater than that defined by MVA Ov A Dly, a MVA Ov Alarm is signaled. ⁽¹⁾	R/W
243	MVA Ov A Dly	Secs	0.1/99.0	0.1	Lets you enter a time value for the Apparent Power Over Alarm Delay (MVA Ov A Dly). If the current actual value of the Apparent Power (MVA) is greater than the MVA Ov A Lvl for a time period greater than that defined by MVA Ov A Dly, a MVA Ov Alarm is signaled. ⁽¹⁾	R/W
244	MVA Un F Lvl	MVA	0.000/1000.000	0.00	Lets you enter a value for the MVA Under Fault Level (MVA Un F Lvl). If the current actual value of the Apparent Power (MVA) is less than the MVA Un F Lvl for a time period greater than that defined by MVA Un F Dly, a MVA Un Fault is signaled. ⁽¹⁾	R/W
245	MVA Un F Dly	Secs	0.1/99.0	0.1	Lets you enter a time value for the Apparent Power Under Fault Delay (MVA Un F Dly). If the current actual value of the Apparent Power (MVA) is less than the MVA Un F Lvl for a time period greater than that defined by MVA Un F Dly, a MVA Un Fault is signaled. ⁽¹⁾	R/W
246	MVA Un A Lvl	MVA	0.000/1000.000	0.00	Lets you enter a value for the MVA Under Alarm Level (MVA Un A Lvl). If the current actual value of the Apparent Power (MVA) is less than the MVA Un A Lvl for a time period greater than that defined by MVA Un A Dly, a MVA Un Alarm is signaled. ⁽¹⁾	R/W
247	MVA Un A Dly	Secs	0.1/99.0	0.1	Lets you enter a time value for the Apparent Power Under Alarm Delay (MVA Un A Dly). If the current actual value of the Apparent Power (MVA) is less than the MVA Un A Lvl for a time period greater than that defined by MVA Un A Dly, a MVA Un Alarm is signaled. ⁽¹⁾	R/W
248	Lead PF Ov F Lvl	—	0.00/1.00	0.00	Lets you enter a value for the Leading Power Factor Over Fault Level (Lead PF Ov F Lvl). If the current actual Power Factor value is leading more than the Lead PF Ov F Lvl for a time period greater than that defined by Lead PF Ov F Dly, a Lead PD Ov Fault is signaled. ⁽¹⁾	R/W
249	Lead PF Ov F Dly	Secs	0.1/99.0	0.1	Lets you enter a time value for the Leading Power Factor Over Fault Delay (Lead PF Ov F Dly). If the current actual Power Factor value is leading more than the Lead PF Ov F Lvl for a period greater than that defined by Lead PF Ov F Dly, a Lead PD Ov fault is signaled. ⁽¹⁾	R/W
250	Lead PF Ov A Lvl	—	0.00/1.00	0.00	Lets you enter a value for the Leading Power Factor Over Alarm Level (Lead PF Ov A Lvl). If the current actual Power Factor value is leading more than the Lead PF Ov A Lvl for a period greater than that defined by Lead PF Ov A Dly, a Lead PD Ov alarm is signaled. ⁽¹⁾	R/W
251	Lead PF Ov A Dly	Secs	0.1/99.0	0.1	Lets you enter a time value for the Leading Power Factor Over Alarm Delay (Lead PF Ov A Dly). If the current actual Power Factor value is leading more than the Lead PF Ov A Lvl for a period greater than that defined by Lead PF Ov A Dly, a Lead PD Ov alarm is signaled. ⁽¹⁾	R/W
252	Lead PF Un F Lvl	—	0.00/1.00	0.00	Lets you enter a value for the Leading Power Factor Under Fault Level (Lead PF Un F Lvl). If the current actual Power Factor value is leading less than the Lead PF Un A Lvl for a time period greater than that defined by Lead PF Un A Dly, a Lead PD Un Fault is signaled. ⁽¹⁾	R/W
253	Lead PF Un F Dly	Secs	0.1/99.0	0.1	Lets you enter a time value for the Leading Power Factor Under Fault Delay (Lead PF Un F Dly). If the current actual Power Factor value is leading less than the Lead PF Un A Lvl for a time period greater than that defined by Lead PF Un A Dly, a Lead PD Un Fault is signaled. ⁽¹⁾	R/W

(1) To implement an Alarm or Fault, the appropriate bit in the Motor Fault En, Parameter 230, or Motor Alarm En, Parameter 231, must also be set.

Table 149 - Parameter 254...263

ENUM Text is not applicable for the parameters in this table.

No.	Name	Units	Min./Max. Values	Default Value	Description	Read/Write Access
254	Lead PF Un A Lvl	—	0.00/1.00	0.00	Lets you enter a value for the Leading Power Factor Under Alarm Level (Lead PF Un A Lvl). If the current actual Power Factor value is leading less than the Lead PF Un A Lvl for a time period greater than that defined by Lead PF Un A Dly, a Lead PD Un Alarm is signaled. ⁽¹⁾	R/W
255	Lead PF Un A Dly	Secs	0.1/99.0	0.1	Lets you enter a time value for the Leading Power Factor Under Alarm Delay (Lead PF Un A Dly). If the current actual Power Factor value is leading less than the Lead PF Un A Lvl for a time period greater than that defined by Lead PF Un A Dly, a Lead PD Un Alarm is signaled. ⁽¹⁾	R/W
256	Lag PF Ov F Lvl	—	-1.00/0.00	0.00	Lets you enter a value for the Lagging Power Factor Over Fault Level (Lag PF Ov F Lvl). If the current actual Power Factor value lags more than the Lag PF Ov F Lvl for a time period greater than that defined by Lag PF Ov F Dly, a Lag PF Ov Fault is signaled. ⁽¹⁾	R/W
257	Lag PF Ov F Dly	Secs	0.1/99.0	0.1	Lets you enter a time value for the Lagging Power Factor Over Fault Delay (Lag PF Ov F Dly). If the current actual Power Factor value lags more than the Lag PF Ov F Lvl for a time period greater than that defined by Lag PF Ov F Dly, a Lag PF Ov Fault is signaled. ⁽¹⁾	R/W
258	Lag PF Ov A Lvl	—	-1.00/0.00	0.00	Lets you enter a value for the Lagging Power Factor Over Alarm Level (Lag PF Ov A Lvl). If the current actual Power Factor value lags more than the Lag PF Ov A Lvl for a time period greater than that defined by Lag PF Ov A Dly, a Lag PF Ov Alarm is signaled. ⁽¹⁾	R/W
259	Lag PF Ov A Dly	Secs	0.1/99.0	0.1	Lets you enter a time value for the Lagging Power Factor Over Alarm Delay (Lag PF Ov A Dly). If the current actual Power Factor value lags more than the Lag PF Ov A Lvl for a time period greater than that defined by Lag PF Ov A Dly, a Lag PF Ov Alarm is signaled. ⁽¹⁾	R/W
260	Lag PF Un F Lvl	—	-1.00/0.00	0.00	Lets you enter a value for the Lagging Power Factor Under Fault Level (Lag PF Un F Lvl). If the current actual Power Factor value lags less than the Lag PF Un F Lvl for a time period greater than that defined by Lag PF Un F Dly, a Lag PF Un Fault is signaled. ⁽¹⁾	R/W
261	Lag PF Un F Dly	Secs	0.1/99.0	0.1	Lets you enter a time value for the Lagging Power Factor Under Fault Delay (Lag PF Un F Dly). If the current actual Power Factor value lags less than the Lag PF Un F Lvl for a time period greater than that defined by Lag PF Un F Dly, a Lag PF Un Fault is signaled. ⁽¹⁾	R/W
262	Lag PF Un A Lvl	—	-1.00/0.00	0.00	Lets you enter a value for the Lagging Power Factor Under Alarm Level (Lag PF Un A Lvl). If the current actual Power Factor value lags less than the Lag PF Un A Lvl for a time period greater than that defined by Lag PF Un A Dly, a Lag PF Un Alarm is signaled. ⁽¹⁾	R/W
263	Lag PF Un A Dly	Secs	0.1/99.0	0.1	Lets you enter a time value for the Lagging Power Factor Under Alarm Delay (Lag PF Un A Dly). If the current actual Power Factor value lags less than the Lag PF Un A Lvl for a period greater than that defined by Lag PF Un A Dly, a Lag PF Un alarm is signaled. ⁽¹⁾	R/W

(1) To implement an Alarm or Fault, the appropriate bit in the Motor Fault En, Parameter 230, or Motor Alarm En, Parameter 231, must also be set.

Table 150 - Parameter 264...281

No.	Name	Units	Min./Max. Values	Default Value	Enum Text [Default]	Description	Read/Write Access
264	Motor Restart En	—	0	0	Overload	Lets you adjust the Motor Restart Enable conditions. Setting (=1) a bit causes the motor to attempt a restart after the selected event is detected. A limit to the number of starts attempted before a fault is signaled can be set in the Restart Attempts parameter. 0 = Do not attempt a restart after fault is cleared 1 = Attempt a restart after this fault is cleared NOTE: Restart attempts, Parameter 133, and Restart Delay, Parameter 134, must also be configured. [All Disabled as Default]	R/W
			0	0	Underload		
			0	0	MWatts Over		
			0	0	MWatts Under		
			0	0	+MVAR Over		
			0	0	+MVAR Under		
			0	0	-MVAR Over		
			0	0	-MVAR Under		
			0	0	MVA Over		
			0	0	MVA Under		
			0	0	Curr Imbal		
			0	0	Jam		
			0	0	Stall		
			0	0	Starts/Hr		
			0	0	PM Hours		
			0	0	PM Starts		
			0	0	Power Qual		
0	0	Open Load					
0	0	THD I					
0	0	Lead PF Un					
0	0	Lead PF Ov					
0	0	Lag PF Un					
0	0	Lag PF Ov					
0	0	Locked Rotor					
265	Voltage Pn Ave	Volts	0/450	0	NA	Displays the average of the sum of the three phase voltages to neutral.	R
266	Voltage Phase A-N					Displays Phase A (L1) to neutral voltage.	
267	Voltage Phase B-N					Displays Phase B (L2) to neutral voltage.	
268	Voltage Phase C-N					Displays Phase C (L3) to neutral voltage.	
269	Real Power A	MW	-1000.000/1000.000	0.000	NA	Displays the Real Power of the Phase A branch which is equal to Phase A Voltage x Phase A Current x PF.	R
270	Real Power B					Displays the Real Power of the Phase B branch which is equal to Phase B Voltage x Phase B Current x PF.	
271	Real Power C					Displays the real power of the Phase C branch which is equal to Phase C Voltage x Phase C Current x PF.	
272	Real Demand	MW	-1000.000/1000.000	0.000	NA	Displays Real Energy (MWH) averaged over a period of time defined by Demand Period.	R
273	Max. Real Demand	MW	-1000.000/1000.000	0.000	NA	Displays the Maximum energy demand recorded since the last energy meter reset.	R
274	Reactive Power A	MVAR	-1000.000/1000.000	0.000	NA	Displays the reactive power of the Phase A branch.	R
275	Reactive Power B					Displays the reactive power of the Phase B branch.	
276	Reactive Power C					Displays the reactive power of the Phase C branch.	
277	Reactive Power	MVAR	-1000.000/1000.000	0.000	NA	Displays the total reactive power.	R
278	Reactive Energy C	MVRH	-1000.000/1000.000	0.000	NA	Displays the reactive energy being consumed by the load.	R
279	Reactive Energy P					Displays the reactive energy being produced by the load.	
280	Reactive Energy					Displays the total reactive energy which is equal to Reactive Power X time.	
281	Reactive Demand	MVAR	-1000.000/1000.000	0.000	NA	Displays the Reactive Energy consumed or generated by the system over the Demand Time Period.	R

Table 151 - Parameter 282...302

ENUM Text is not applicable for the parameters in this table.

No.	Name	Units	Min./Max. Values	Default Value	Description	Read/Write Access
282	Max. Reactive Dmd	MVAR	-1000.000/ 1000.000	0.000	Displays the maximum reactive energy demand recorded since the energy meters were reset	R
283	Apparent Power A	MVA	-1000.000/ 1000.000	0.000	Displays the Apparent Power (VA) measured in the phase A branch.	R
284	Apparent Power B				Displays the VA measured in the phase B branch.	
285	Apparent Power C				Displays the VA measured in the phase C branch.	
286	Apparent Power	MVA	-1000.000/ 1000.000	0.000	Displays the total apparent power consumed (-) or produced (+) by the load.	R
287	Apparent Energy	MVAH	-1000.000/ 1000.000	0.000	Displays the Apparent Energy which is equal to Apparent Power x Time.	R
288	Apparent Demand	MVA	-1000.000/ 1000.000	0.000	Displays the total amount of Apparent Energy which is equal to MVAH x demand period produced or consumed by the load.	R
289	Max. Apparent Dmd	MVA	-1000.000/ 1000.000	0.000	Displays the maximum apparent demand recorded since energy meters were reset.	R
290	Demand Period	Mins	1/255	1	Lets you enter the time period that energy samples are taken to calculate demand.	R/W
291	Num of Periods	—	1/15	1	Lets you enter the number of periods that energy measurements are taken in calculating demand.	R/W
292	Power Factor A	—	-1.00/1.00	0.00	Displays the power factor in the Phase A branch of the load circuit.	R
293	Power Factor B				Displays the power factor in the Phase B branch of the load circuit.	
294	Power Factor C				Displays the power factor in the Phase C branch of the load circuit.	
295	Current Imbal	%	0/100	0.00	Displays the percent current imbalance measured in the load circuit (max deviation of current from the average of three currents / average current of three currents).	R
296	Voltage Imbal	%	0/100	0.00	Displays the percent voltage imbalance measured in the load circuit (max deviation of voltage from the average of three voltages / average voltage of three voltages).	R
297	-MVAR Ov F Lvl	MVAR	-1000.000/ 0.000	0.000	Lets you enter a value for the Generated Reactive Power Over Fault Level (-MVAR Ov F Lvl). If the current actual value for Generated Reactive Power is more than the -MVAR Ov F Lvl for a period greater than that defined by -MVAR Ov F Dly, a -MVAR Ov fault is signaled. ⁽¹⁾	R/W
298	-MVAR Ov F Dly	Secs	0.1/99.0	0.1	Lets you enter a time value for the Generated Reactive Power Over Fault Delay (-MVAR Ov F Dly). If the current actual value for the Generated Reactive Power is more than the -MVAR Ov F Lvl for a time period greater than that defined by -MVAR Ov F Dly, a -MVAR Ov fault is signaled. ⁽¹⁾	R/W
299	-MVAR Ov A Lvl	MVAR	-1000.000/ 0.000	0.000	Lets you enter a value for the Generated Reactive Power Over Alarm Level (-MVAR Ov A Lvl). If the current actual value for Generated Reactive Power is more than the -MVAR Ov A Lvl for a period greater than that defined by -MVAR Ov A Dly, a -MVAR Ov Alarm is signaled. ⁽¹⁾	R/W
300	-MVAR Ov A Dly	Secs	0.1/99.0	0.1	Lets you enter a time value for the Generated Reactive Power Over Alarm Delay (-MVAR Ov A Dly). If the current actual value for the Generated Reactive Power is more than the -MVAR Ov A Lvl for a period greater than that defined by -MVAR Ov A Dly, a -MVAR Ov alarm is signaled. ⁽¹⁾	R/W
301	-MVAR Un F Lvl	MVAR	-1000.000/ 0.000	0.000	Lets you enter a value for the Generated Reactive Power Under Fault Level (-MVAR Un F Lvl). If the current actual value for Generated Reactive Power is less than the -MVAR Un F Lvl for a period greater than that defined by -MVAR Un F Dly, a -MVAR Un Fault is signaled. ⁽¹⁾	R/W
302	-MVAR Un F Dly	Secs	0.1/99.0	0.1	Lets you enter a time value for the Generated Reactive Power Under Fault Delay (-MVAR Un F Dly). If the current actual value for Generated Reactive Power is less than the -MVAR Un F Lvl for a period greater than that defined by -MVAR Un F Dly, a -MVAR Un Fault is signaled. ⁽¹⁾	R/W

(1) To implement an Alarm or Fault, the appropriate bit in the Motor Fault En, Parameter 230, or Motor Alarm En, Parameter 231, must also be set.

Table 152 - Parameter 303...311

No.	Name	Units	Min./Max. Values	Default Value	Enum Text [Default]	Description	Read/Write Access	
303	-MVAR Un A Lvl	MVAR	-1000.000/ 0.000	0.000	NA	Lets you enter a value for the Generated Reactive Power Under Alarm Level (-MVAR Un A Lvl). If the current actual value for Generated Reactive Power is less than the -MVAR Un A Lvl for a period greater than that defined by -MVAR Un A Dly, a MVAR Un Alarm is signaled. ⁽¹⁾	R/W	
304	-MVAR Un A Dly	Secs	0.1/99.0	0.1	NA	Lets you enter a time value for the Generated Reactive Power Under Alarm Delay (-MVAR Un A Dly). If the current actual value for Generated Reactive Power is less than the -MVAR Un A Lvl for a period greater than that defined by -MVAR Un A Dly, a -MVAR Un Alarm is signaled. ⁽¹⁾	R/W	
305	Starting Torque	%	0/300	100	NA	Lets you enter Starting Torque value required for a torque start operation.	R/W	
306	Starting Torque 2					Lets you enter an alternate Starting Torque required for a torque start operation.		
307	SS Ref Gain	—	0.10/2.00	1.00	NA	Lets you enter Slow Speed Reference Gain value (SS Ref Gain) used to adjust slow speed operation. ⁽²⁾	R/W	
308	SS Trans Gain					Lets you enter Slow Speed Transfer Gain value (SS Trans Gain) used to adjust slow speed operation. ⁽²⁾		
309	Input Status	—	0/65535	0		Displays the status of all the digital inputs for the SMC-50 controller.	R	
						Input 1		Bit 0 - Displays status of Control Module Input #1.
						Input 2		Bit 1 - Displays status of Control Module Input #2.
						Input 7-1		Bit 2 - Displays status of Control Module Port 7, 150-SM4 Option Module Input #1.
						Input 7-2		Bit 3 - Displays status of Control Module Port 7, 150-SM4 Option Module Input #2.
						Input 7-3		Bit 4 - Displays status of Control Module Port 7, 150-SM4 Option Module Input #3.
						Input 7-4		Bit 5 - Displays status of Control Module Port 7, 150-SM4 Option Module Input #4.
						Input 8-1		Bit 6 - Displays status of Control Module Port 8, 150-SM4 Option Module Input #1.
						Input 8-2		Bit 7- Displays status of Control Module Port 8, 150-SM4 Option Module Input #2.
						Input 8-3		Bit 8- Displays status of Control Module Port 8, 150-SM4 Option Module Input #3.
						Input 8-4		Bit 9- Displays status of Control Module Port 8, 150-SM4 Option Module Input #4.
						Input 9-1		Bit 10 - Displays status of Control Module Port 9, 150-SM4 Option Module Input #1.
						Input 9-2		Bit 11 - Displays status of Control Module Port 9, 150-SM4 Option Module Input #2.
						Input 9-3		Bit 12 - Displays status of Control Module Port 9, 150-SM4 Option Module Input #3.
						Input 9-4		Bit 13 - Displays status of Control Module Port 9, 150-SM4 Option Module Input #4.
		Bit 14 and 15 - Reserved.						
310	Locked Rotor A Lvl	%FLC	400/1000	600	NA	Lets you enter a value for the Locked Rotor Alarm Level (Locked Rtr A Lvl). The locked rotor value represents the motor peak phase current to the load that if exceeded for the period defined in Locked Rtr A Delay signals a fault. The Locked Rotor bit in the Motor Alarm En parameter must be set to signal a alarm. ⁽¹⁾	R/W	
311	Locked Rotor A Dly	Secs	0.1/100.0	0.1	NA	The time period that the peak phase current exceeds the Locked Rtr F Level to signal a fault. You must set the Locked Rotor bit in the Motor Fault En parameter to enable a fault. ⁽¹⁾	R/W	

(1) To implement an Alarm or Fault, the appropriate bit in the Motor Fault En, Parameter 230, or Motor Alarm En, Parameter 231, must also be set.

(2) This parameter is rarely adjusted. Contact Rockwell Automation Technical Support for further information.

Table 153 - Parameters 312...322

No.	Name	Units	Min./Max. Values	Default Value	Enum Text	Description	Read/Write Access
312	Product Command	—	0/65535	0		Displays an image of the DPI product command required for DPI communications.	R
					Stop	1 – Coast / Inhibit 0 – No Action	
					Start	1 – Start 0 – No Action	
					Jog	1 – Stop Maneuver / Inhibit 0 – No Action	
					Clear Fault	1 – Clear Faults 0 – No Action	
					Slow Speed	1 – Run at Slow Speed 0 – No Action	
					Emer Run	1 – Enable Emergency Run Mode 0 – Disable Emergency Run Mode	
					Motor Heater	1 – Enable Motor Winding Heater 0 – Disable Motor Winding Heater	
					Reserved	0	
					Reserved	0	
					Reserved	0	
					Reserved	0	
					Aux Enable	1 – Use the Network #1 - #4 bits 0 – Ignore the Network #1 - #4 bits	
					Network_1	1 – Closes any Output Configured for “Network 1” 0 – Opens any Output Configured for “Network 1”	
Network_2	1 – Closes any Output Configured for “Network 2” 0 – Opens any Output Configured for “Network 2”						
Network_3	1 – Closes any Output Configured for “Network 3” 0 – Opens any Output Configured for “Network 3”						
Network_4	1 – Closes any Output Configured for “Network 4” 0 – Opens any Output Configured for “Network 4”						
313	Rebalance Level	%	0/100	0	NA	The percentage of motor current imbalance above which the SMC-50 controller rebalances the motor current	R/W
314	Va Peak	Volt	0/15000	0	NA	The peak value of the Phase A line to neutral voltage during the motor start, run, and stop cycle. The value resets to 0 when the motor starts.	R
315	Vb Peak	Volt	0/15000	0	NA	The peak value of the Phase B line to neutral voltage during the motor start, run, and stop cycle. The value resets to 0 when the motor starts.	R
316	Vc Peak	Volt	0/15000	0	NA	The peak value of the Phase C line to neutral voltage during the motor start, run, and stop cycle. The value resets to 0 when the motor starts.	R
317	Ia Peak	Amps	0/15000	0	NA	The peak value of the Phase A current during the motor start, run, and stop cycle. The value resets to 0 when the motor starts.	R
318	Ib Peak	Amps	0/15000	0	NA	The peak value of the Phase B current during the motor start, run, and stop cycle. The value resets to 0 when the motor starts.	R
319	Ic Peak	Amps	0/15000	0	NA	The peak value of the Phase C current during the motor start, run, and stop cycle. The value resets to 0 when the motor starts.	R
320	SSVolts Phas A-B	Volt	0/700	0	NA	Snapshot of the Phase A-B voltage when a fault occurs. The value is overwritten if a subsequent fault occurs	R
321	SSVolts Phas B-C	Volt	0/700	0	NA	Snapshot of the Phase B-C voltage when a fault occurs. The value is overwritten if a subsequent fault occurs.	R
322	SSVolts Phas C-A	Volt	0/700	0	NA	Snapshot of the Phase C-A voltage when a fault occurs. The value is overwritten if a subsequent fault occurs.	R

Table 154 - Parameter 323...333

ENUM Text is not applicable for the parameters in this table.

No.	Name	Units	Min./Max. Values	Default Value	Description	Read/Write Access
323	SSCurrent Phas A	Amps	0/15000	0	Snapshot of the Phase A current when a fault occurs. The value is overwritten if a subsequent fault occurs.	R
324	SSCurrent Phas B	Amps	0/15000	0	Snapshot of the Phase B current when a fault occurs. The value is overwritten if a subsequent fault occurs.	R
325	SSCurrent Phas C	Amps	0/15000	0	Snapshot of the Phase C current when a fault occurs. The value is overwritten if a subsequent fault occurs.	R
326	SSPower Factor	—	-1.00/1.00	0	Snapshot of the Motor Power Factor when a fault occurs. The value is overwritten if a subsequent fault occurs.	R
327	SSMtr Thrm Usage	%MT U	0/200	0	Snapshot of the Motor Thermal Usage when a fault occurs. The value is overwritten if a subsequent fault occurs.	R
328	SSMotor Speed	%	0/100	0	Snapshot of the Motor Speed when a fault occurs. The value is overwritten if a subsequent fault occurs.	R
329	SSTHD Vave	%	0.0/1000.0	0	Snapshot of the average voltage Total Harmonic Distortion (THD) when a fault occurs. The value is overwritten if a subsequent fault occurs,	R
330	SSTHD lave	%	0.0/1000.0	0	Snapshot of the average current Total Harmonic Distortion (THD) when a fault occurs. The value is overwritten if a subsequent fault occurs.	R
331	SSProduct Status	—	0/65535	0	Snapshot of the product status when a fault occurs. The value is overwritten if a subsequent fault occurs.	R
					1 – Ready	
					0 – Not Ready	
					1 – Power Applied to Motor (Gating SCRs or Bypass closed)	
					0 – Power NOT Applied to Motor	
					1 – ABC Phasing	
					0 – CBA Phasing	
					1 – 3-phase is valid	
					0 – No valid 3-phase detected	
					1 – Performing a Start Maneuver (slow speed not included)	
					0 – Not Performing a Start Maneuver	
					1 – Performing a Stop Maneuver (coast to stop not included)	
					0 – Not Performing a Stop Maneuver	
					1 – Alarm Present	
					0 – No Alarm Present	
					1 – Fault Condition Exists and hasn't been cleared	
					0 – No Fault Condition	
					1 – Full Voltage Applied (Bypass or full SCR conduction)	
					0 – Not Full Voltage Applied	
					1 – Start/Isolate Contactor Enabled	
0 – Start/Isolate Contactor Disabled						
1 – Bypass Contactor Enabled						
0 – Bypass Contactor Disabled						
1 indicates that the SMC is ready to accept a Start command. The device is not faulted or in the process of stopping, starting or jogging.						
Always 0						
Control Module Input #1 Status. 1 = Input Closed						
Control Module Input #2 Status. 1 = Input Closed						
332	SSBoard Temp	degC	-25/100	20	Snapshot of the internal temperature of the SMC control module when a fault occurs. The value is overwritten if a subsequent fault occurs	R
333	SSLine Frequency	HZ	0/100	0	Snapshot of the line frequency of the three phase voltage when a fault occurs. The value is overwritten if a subsequent fault occurs	R

Table 155 - Parameter 334...346

Unit data is not valid for the parameters in this table.

No.	Name	Units	Min./Max. Values	Default Value	Enum Text [Default]	Description	Read/Write Access
334	Restart Auto	—	—	all disabled	Volt Unbal Overvoltage Undervoltage Line Loss	Modifies the Auto Restarting of the selected faults so that the restart is attempted when the fault condition is removed rather than after a fixed time delay.	R/W
335	DLX Input 1	—	-2147483648... 2147483647	0	NA	General-purpose parameter used as an input to the DeviceLogix Engine.	R/W
336	DLX Input 2	—	-2147483648... 2147483647	0	NA	General-purpose parameter used as an input to the DeviceLogix Engine.	R/W
337	DLX DL Input 1	—	0 / 159999	1	NA	General-purpose datalink used to select another parameter within the SMC-50 controller as an input to the DeviceLogix Engine.	R/W
338	DLX DL Input 2	—	0 / 159999	1	NA	General-purpose datalink used to select another parameter within the SMC-50 controller as an input to the DeviceLogix Engine.	R/W
339	DLX DL Input 3	—	0 / 159999	1	NA	General-purpose datalink used to select another parameter within the SMC-50 controller as an input to the DeviceLogix Engine.	R/W
340	DLX DL Input 4	—	0 / 159999	1	NA	General-purpose datalink used to select another parameter within the SMC-50 controller as an input to the DeviceLogix Engine.	R/W
341	DLX DL Input 5	—	0 / 159999	1	NA	General-purpose datalink used to select another parameter within the SMC-50 controller as an input to the DeviceLogix Engine.	R/W
342	DLX DL Input 6	—	0 / 159999	1	NA	General-purpose datalink used to select another parameter within the SMC-50 controller as an input to the DeviceLogix Engine.	R/W
343	DLX Output 1	—	-2147483648... 2147483647	0	NA	General-purpose parameter that can be written by the DeviceLogix engine and monitored from a HIM or network device.	R
344	DLX Output 2	—	-2147483648... 2147483647	0	NA	General-purpose parameter that can be written by the DeviceLogix engine and monitored from a HIM or network device.	R
345	DLX Command	—	—	—	Ready Enable Disable	Lets you enable or disable the DeviceLogix engine. Once the "Enable" or "Disable" command has been executed the parameter automatically reverts back to "Ready".	R/W
346	DLX Status	—	—	—	Enable Disable	Indicates the current state of the DeviceLogix engine.	R
347	Load Type	—	0/1	0	—	Allows choice of Motor Load or Resistive Heater Load	R/W
					[Motor]	Motor Load	
					Resistive	Resistive Heater Load	
348	Ref Source	--	0/8	0	—	Allows selection of Source for Resistive Heater Output Voltage	R/W
					[Output V Ref]	Output Voltage Reference Parameter	
					P7 In1	Analog Input #1 from 150-SM3 option module in Expansion Port 7	
					P7 In2	Analog Input #2 from 150-SM3 option module in Expansion Port 7	
					P8 In1	Analog Input #1 from 150-SM3 option module in Expansion Port 8	
					P8 In2	Analog Input #2 from 150-SM3 option module in Expansion Port 8	
					P9 In1	Analog Input #1 from 150-SM3 option module in Expansion Port 9	
					P9 In2	Analog Input #2 from 150-SM3 option module in Expansion Port 9	
					DLX Output 1	DeviceLogix Output #1	
DLX Output 2	DeviceLogix Output #2						
349	Output V Ref	%	1/100	1	N/A	Parameter that can be set from 1% to 100% output voltage for Resistive Heating Mode.	R/W
350	Slow Speed 2	%	-15 / +15	+10	N/A	Allows you to program a second Slow Speed Reference	R/W

150-SM6 PCM Information**Table 156 - Parameter X.1...X.9**

Unit data is not valid for the parameters in this table.

No. ⁽¹⁾	Name	Min./Max. Values	Default Value	Enum Text	Description	Read/Write Access
X.1	Module Status	0/1	1	—	Displays information about the operational status of the 150-SMB Parameter Configuration Option I/O Module.	R
				Ready	Bit 0 - Ready; Bit Set = 1 indicates the module is ready for operation.	R
X.2	Rotary Switch 1	0/15	0	NA	Displays the numeric position of Rotary Switch 1 = Initial Torque	R
X.3	Rotary Switch 2	0/15	0	NA	Displays the numeric position of Rotary Switch 2 = Current Limit.	R
X.4	Rotary Switch 3	0/15	0	NA	Displays the numeric position of Rotary Switch 3 = Ramp Time.	R
X.5	Rotary Switch 4	0/15	0	NA	Displays the numeric position of Rotary Switch 4 = Stop Time.	R
X.6	Rotary Switch 5	0/15	0	NA	Displays the numeric position of Rotary Switch 5 = Motor FLC.	R
X.7	Device Config	0/255	0	NA	Displays the Device Config DIP switch bit status (1=Sw ON and 2=Sw OFF).	R
X.8	Protect Config	0/255	0	NA	Displays the Protect Config DIP switch bit status (1=Sw ON and 2=Sw OFF).	R
X.9	IO Config	0/255	0	NA	Displays the IO Config DIP switch bit status (1=Sw ON and 2=Sw OFF).	R

(1) X indicates the Control Module port number in which the 150-SM6 Option Module is installed. Allowable ports = 7, 8, or 9.

150-SM4 Digital I/O Module Information**Table 157 - Parameter X.1...X.18**

No. ⁽¹⁾	Name	Min./Max. Values	Default Value	Units	Enum Text [Default]	Description	Read/Write Access
X.1	Module Status	0/256	0	NA	—	Displays information about the operational status of the 150-SM4 Digital I/O Option Module.	R
					Ready	Bit 0 = Ready; Bit Set = indicates the module is ready for operation.	
					Input 1	Bit 1 = Input 1; Bit Set (1) indicates the input is ON.	
					Input 2	Bit 2 = Input 2; Bit Set (1) indicates the input is ON.	
					Input 3	Bit 3 = Input 3; Bit Set (1) indicates the input is ON.	
					Input 4	Bit 4 = Input 4; Bit Set (1) indicates the input is ON.	
					Aux 1	Bit 5 = Aux 1; Bit Set (1) indicates the auxiliary relay output is ON.	
					Aux 2	Bit 6 = Aux 2; Bit Set (1) indicates the auxiliary relay output is ON.	
					Aux 3	Bit 7 = Aux 3; Bit Set (1) indicates the auxiliary relay output is ON.	
					Bit 8-15 Spare	Bit 8-15 Spare	

No. (1)	Name	Min./Max. Values	Default Value	Units	Enum Text [Default]	Description	Read/Write Access
X.2	Input 1	0/13	0	NA	—	Lets you select the operation of Input Terminal A1, Option Input 1 on the 150-SM4 Digital I/O Option Module.	R/W
					[Disable]	Disable the input; ignores any assertion to Input A1 Terminal (High).	
					Start	Initiate a start as set up by the start parameters at Input Terminal A1.	
					Coast	Initiates a coast stop; no current to motor at Input Terminal A1 (Low).	
					Stop Option	Initiates a stop maneuver as set up by the stopping parameters at Input Terminal A1 (Low).	
					Start/Coast	If Input Terminal A1 = 0 stops motor, 1 initiates a start as set up by the start parameters.	
					Start/Stop	If Input Terminal A1 = 0 initiates a stop maneuver as set up by stopping parameters, 1 initiates a start as set up b the start parameters.	
					Slow Speed 1	Runs motor in slow speed mode 1 as set up by slow speed 1 parameters (High).	
					Slow Speed 2	Runs motor in slow speed mode 2 as set up by slow speed 2 parameters (High).	
					Dual Ramp	If Input Terminal A1 = 0, use starting mode 1; 1, use starting mode 2.	
					OL Select	If Input Terminal A1 = 0, use Motor Overload Class 1; 1, use Motor Overload Class 2.	
					Fault	A fault condition is forced if Input Terminal A1 = 1.	
					Fault NC	A fault condition is forced if Input Terminal A1 = 0.	
					Clear Fault	Clear a fault from Input Terminal A1 (High).	
					Emerg Run	Allows motor to run in emergency run mode if asserted from Input Terminal A1; does not start motor (High).	
Motor Heater	Runs motor heating algorithm if asserted at Input Terminal A1 (High).						
X.3	Input 2	0/13	0	NA	—	Lets you select the operation of Input Terminal A2, Option Input 2 on the 150-SM4 Digital I/O Option Module.	R/W
					[Disable]	Disable the input; ignores any assertion to Input A2 Terminal.	
					Start	Initiate a start as set up by the start parameters at Input Terminal A2 (High).	
					Coast	Initiates a coast stop; no current to motor at Input Terminal A2 (Low).	
					Stop Option	Initiates a stop maneuver as set up by the stopping parameters at Input Terminal A2 (High).	
					Start/Coast	If Input Terminal A2 = 0 stops motor, 1 initiates a start as set up by the start parameters.	
					Start/Stop	If Input Terminal A2 = 0 initiates a stop maneuver as set up by stopping parameters, 1 initiates a start as set up b the start parameters.	
					Slow Speed 1	Runs motor in slow speed mode 1 as set up by slow speed 1 parameters (High).	
					Slow Speed 2	Runs motor in slow speed mode 2 as set up by slow speed 2 parameters (High).	
					Dual Ramp	If Input Terminal A2 = 0, use starting mode 1; 1, use starting mode 2.	
					OL Select	If Input Terminal A2 = 0, use Motor Overload Class 1; 1, use Motor Overload Class 2.	
					Fault	A fault condition is forced if Input Terminal A2 = 1.	
					Fault NC	A fault condition is forced if Input Terminal A2 = 0.	
					Clear Fault	Clear a fault from Input Terminal A2 (High).	
					Emerg Run	Allows motor to run in emergency run mode if asserted from Input Terminal A2; does not start motor (High).	
Motor Heater	Runs motor heating algorithm if asserted at Input Terminal A2 (High).						

No. ⁽¹⁾	Name	Min./Max. Values	Default Value	Units	Enum Text [Default]	Description	Read/Write Access
X.4	Input 3	0/13	0	NA	—	Lets you select the operation of Input Terminal A3, Option Input 3 on the 150-SM4 Digital I/O Option Module.	R/W
					[Disable]	Disable the input; ignores any assertion to Input A3 Terminal.	
					Start	Initiate a start as set up by the start parameters at Input Terminal A3 (High).	
					Coast	Initiates a coast stop; no current to motor at Input Terminal A3 (Low).	
					Stop Option	Initiates a stop maneuver as set up by the stopping parameters at Input Terminal A3 (Low).	
					Start/Coast	If Input Terminal A3 = 0 stops motor, 1 initiates a start as set up by the start parameters.	
					Start/Stop	If Input Terminal A3 = 0 initiates a stop maneuver as set up by stopping parameters, 1 initiates a start as set up b the start parameters.	
					Slow Speed 1	Runs motor in slow speed mode 1 as set up by slow speed 1 parameters (High).	
					Slow Speed 2	Runs motor in slow speed mode 2 as set up by slow speed 2 parameters (High).	
					Dual Ramp	If Input Terminal A3 = 0, use starting mode 1; 1, use starting mode 2.	
					OL Select	If Input Terminal A3 = 0, use Motor Overload Class 1; 1, use Motor Overload Class 2.	
					Fault	A fault condition is forced if Input Terminal A3 = 1.	
					Fault NC	A fault condition is forced if Input Terminal A3 = 0.	
					Clear Fault	Clear a fault from Input Terminal A3 (High).	
					Emerg Run	Allows motor to run in emergency run mode if asserted from Input Terminal A3; does not start motor (High).	
Motor Heater	Runs motor heating algorithm if asserted at Input Terminal A3 (High).						
X.5	Input 4	0/13	0	NA	—	Lets you select the operation of Input Terminal A4, Option Input 4 on the 150-SM4 Digital I/O Option Module.	R/W
					[Disable]	Disable the input; ignores any assertion to Input A4 Terminal.	
					Start	Initiate a start as set up by the start parameters at Input Terminal A4 (High).	
					Coast	Initiates a coast stop; no current to motor at Input Terminal A4 (Low).	
					Stop Option	Initiates a stop maneuver as set up by the stopping parameters at Input Terminal A4.	
					Start/Coast	If Input Terminal A4 = 0 stops motor, 1 initiates a start as set up by the start parameters.	
					Start/Stop	If Input Terminal A4 = 0 initiates a stop maneuver as set up by stopping parameters, 1 initiates a start as set up b the start parameters.	
					Slow Speed 1	Runs motor in slow speed mode 1 as set up by slow speed 1 parameters (High).	
					Slow Speed 2	Runs motor in slow speed mode 2 as set up by slow speed 2 parameters (High).	
					Dual Ramp	If Input Terminal A4 = 0, use starting mode 1; 1, use starting mode 2.	
					OL Select	If Input Terminal A4 = 0, use Motor Overload Class 1; 1, use Motor Overload Class 2.	
					Fault	A fault condition is forced if Input Terminal A4 = 1.	
					Fault NC	A fault condition is forced if Input Terminal A4 = 0.	
					Clear Fault	Clear a fault from Input Terminal A4 (High).	
					Emerg Run	Allows motor to run in emergency run mode if asserted from Input Terminal A4; does not start motor (High).	
Motor Heater	Runs motor heating algorithm if asserted at Input Terminal A4 (Low).						

No. (1)	Name	Min./Max. Values	Default Value	Units	Enum Text [Default]	Description	Read/Write Access
X.6	Aux1 Config	0/12	0	NA	—	Lets you configure the functionality of the Aux1 Relay Output on the 150-SM4 Digital I/O Option Module.	R/W
					[Normal]	Aux1 closes when start asserted, opens when motor stops.	
					Up-to-Speed	Aux1 closes when motor reaches up-to-speed and opens when the motor is not at speed.	
					Fault	Aux1 closes when the SMC-50 controller enters a fault state and opens when the fault is cleared.	
					Alarm	Aux1 closes when the SMC-50 controller detects an alarm condition and opens when the alarm is cleared.	
					Ext Bypass	Aux1 closes when the SMC-50 controller enters the external bypass mode and opens when it leaves that mode (SCR Control).	
					Ext Brake	Aux1 closes when the external braking command is active and opens when it is not active.	
					Device Logix	Aux1 is controlled by the Device Logix program.	
					Aux Control	When an auxiliary output is configured for Aux Control, a bit within the parameter Aux Control controls the state of the auxiliary.	
					Network 1	With an auxiliary configured as Network 1, it is controlled over the LAN as Relay 1.	
					Network 2	With an auxiliary configured as Network 2, it is controlled over the LAN as Relay 2.	
					Network 3	With an auxiliary configured as Network 3, it is controlled over the LAN as Relay 3.	
					Network 4	With an auxiliary configured as Network 4, it is controlled over the LAN as Relay 4.	
Fan Control	Used to control fans.Fan is turned on when the motor is running or the estimated SCR temperature is above 50°C						
X.7	Aux1 Invert	0/1	0	NA	—	Lets you invert the logic of the Aux1 output. When disabled, it is a normally open relay output contact when de-energized. By enabling the invert function, the relay contact becomes a normally closed contact when de-energized.	R/W
					[Disable]	Aux1 Relay Output is not inverted (N.O.).	
					Enable	Aux1 Relay Output is inverted (N.C.) ⁽²⁾ .	
X.8	Aux1 On Delay	0.0/10.0	0.0	sec	NA	A user-selected time delay in activating the Aux1 Relay Contact can be programmed.	R/W
X.9	Aux1 Off Delay	0.0/10.0	0.0	sec	NA	A user-selected time delay in de-activating the Aux1 Relay Contact can be programmed.	R/W
X.10	Aux2 Config	0/12	0	NA	—	Lets you configure the functionality of the Aux2 Relay Output on the 150-SM4 Digital I/O Option Module.	R/W
					[Normal]	Aux2 closes when start asserted, opens when motor stops.	
					Up-to-Speed	Aux2 closes when motor reaches up-to-speed and opens when the motor is not at speed.	
					Fault	Aux2 closes when the SMC-50 controller enters a fault state and opens when the fault is cleared.	
					Alarm	Aux2 closes when the SMC-50 controller detects an alarm condition and opens when the alarm is cleared.	
					Ext Bypass	Aux2 closes when the SMC-50 controller enters the external bypass mode and opens when it leaves that mode (SCR Control).	
					Ext Brake	Aux2 closes when the external braking command is active and opens when it is not active.	
					Device Logix	Aux2 is controlled by the Device Logix program	
					Aux Control	When an auxiliary output is configured for Aux Control, a bit within the parameter Aux Control controls the state of the auxiliary.	
					Network 1	With an auxiliary configured as Network 1, it is controlled over the LAN as Relay 1.	
					Network 2	With an auxiliary configured as Network 2, it is controlled over the LAN as Relay 2.	
					Network 3	With an auxiliary configured as Network 3, it is controlled over the LAN as Relay 3.	
					Network 4	With an auxiliary configured as Network 4, it is controlled over the LAN as Relay 4.	
Fan Control	Used to control fans.Fan is turned on when the motor is running or the estimated SCR temperature is above 50°C						

No. ⁽¹⁾	Name	Min./Max. Values	Default Value	Units	Enum Text [Default]	Description	Read/Write Access
X.11	Aux2 Invert	0/1	0	NA	—	Lets you invert the logic of the Aux2 output. When disabled, it is a normally open relay output contact when de-energized. By enabling the invert function, the relay contact becomes a normally closed contact when de-energized.	R/W
					[Disable]	Aux2 Relay Output is not inverted (N.O.).	
					Enable	Aux2 Relay Output is inverted (N.C.) ?	
X.12	Aux2 On Delay	0.0/10.0	0.0	sec	NA	A user-selected time delay in activating the Aux2 Relay Contact can be programmed.	R/W
X.13	Aux2 Off Delay	0.0/10.0	0.0	sec	NA	A user-selected time delay in de-activating the Aux2 Relay Contact can be programmed.	R/W
X.14	Aux3 Config	0/12	0	NA	—	Lets you configure the functionality of the Aux3 Relay Output on the 150-SM4 Digital I/O Option Module.	R/W
					[Normal]	Aux3 closes when start asserted, opens when motor stops.	
					Up-to-Speed	Aux3 closes when motor reaches Up-to-Speed and opens when the motor is not at speed.	
					Fault	Aux3 closes when the SMC-50 controller enters a fault state and opens when the fault is cleared.	
					Alarm	Aux3 closes when the SMC-50 controller detects an alarm condition and opens when the alarm is cleared.	
					Ext Bypass	Aux3 closes when the SMC-50 controller enters the external bypass mode and opens when it leaves that mode (SCR Control).	
					Ext Brake	Aux3 closes when the external braking command is active and opens when it is not active.	
					Device Logix	Aux3 is controlled by the Device Logix program	
					Aux Control	When an auxiliary output is configured for Aux Control, a bit within the parameter Aux Control controls the state of the auxiliary.	
					Network 1	With an auxiliary configured as Network 1, it is controlled over the LAN as Relay 1.	
					Network 2	With an auxiliary configured as Network 2, it is controlled over the LAN as Relay 2.	
					Network 3	With an auxiliary configured as Network 3, it is controlled over the LAN as Relay 3.	
Network 4	With an auxiliary configured as Network 4, it is controlled over the LAN as Relay 4.						
Fan Control	Used to control fans. Fan is turned on when the motor is running or the estimated SCR temperature is above 50°C						
X.15	Aux3 Invert	0/1	0	NA	—	Lets you invert the logic of the Aux3 output. When disabled, it is a normally open relay output contact when de-energized. By enabling the invert function, the relay contact becomes a normally closed contact when de-energized.	R/W
					[Disable]	Aux3 Relay Output is not inverted (N.O.).	
					Enable	Aux3 Relay Output is inverted (N.C.) ⁽²⁾ .	
X.16	Aux3 On Delay	0.0/10.0	0.0	sec	NA	A user-selected time delay in activating the Aux3 Relay Contact can be programmed.	R/W
X.17	Aux3 Off Delay	0.0/10.0	0.0	sec	NA	A user-selected time delay in de-activating the Aux3 Relay Contact can be programmed.	R/W
X.18	Parameter Management	0/1	0	NA	—	Lets you set all 150-SM4 Digital I/O Option Module parameters to default values.	R/W
					[Ready]	Waiting for command to set defaults.	
					Factory Default	Set all writable parameters to factory default values.	

(1) X indicates the Control Module port number in which the 150-SM4 Option Module is installed. Allowable ports = 7, 8, or 9.

(2) N.C. is electrically held closed.

150-SM2 Ground Fault Module Information

Table 158 - Parameter X.1...X.19

No. (1)	Name	Min./Max. Values	Default Value	Units	Enum Text	Description	Read/Write Access
X.1	Module Status	0/7	7	NA	—	Displays information about the operational status of the 150-SM2 PTC, Ground Fault, and External Current Transformer (CT) Option Module.	R
					Ready	Bit 0 = Ready; Bit Set = 1 indicates the module is ready for operation.	
					PTC	Bit 1 = PTC; 1 = PTC Indicating Fault 0; = No fault	
					CT Loss	Bit 2 = CT Loss; 1 = CT disconnected; 0 = CT Connected	
X.2	Fault Enable	0/3	0	NA	—		R/W
					PTC	0 = PTC Fault Disabled; 1 = PTC Fault Enabled	
					Ground Fault	0 = Ground Fault Disabled; 1 = Ground Fault Enabled	
X.3	Alarm Enable	0/3	0	NA	—		R/W
					PTC	0 = PTC Alarm Disabled; 1 = PTC Alarm Enabled	
					Ground Fault	0 = Ground Fault Alarm Disabled; 1 = Ground Fault Alarm Enabled	
X.4	Restart Enable	0/3	0	NA	—		R/W
					PTC	0 = does not restart after PTC Fault is cleared; 1 = restart after PTC Fault is cleared	
					Ground Fault	0 = does not restart after the Ground Fault is cleared; 1 = restart after the Ground Fault is cleared	
X.5	Turns Ratio	100/2000	1000	:1	NA	Enables user to configure the turns ratio for the CT being used.	R/W
X.6	Gnd Flt Level	0.00/5.00	2.50	Amps	NA	Lets you configure the level (value) of ground current that determines a ground fault condition.	R/W
X.7	Gnd Flt Delay	0.1/250.0	0.5	Secs	NA	Sets the time limit that the ground fault level must be exceeded before signaling a fault.	R/W
X.8	Gnd Flt A Level	0.00/5.00	2.50	Amps	NA	Sets the level of ground current that determines a ground fault alarm condition.	R/W
X.9	Gnd Flt A Delay	0.1/250.0	0.5	Secs	NA	Sets the time limit that the ground fault level must be exceeded before signaling an alarm.	R/W
X.10	Gnd Flt Inh Time	0.0/250.0	10.0	Secs	NA	User configurable time delay to inhibit ground fault after a start.	R/W
X.11	Ground Current	0.00/5.00	0.00	Amps	NA	Measured ground current.	R/W
X.12	CT Enable	0/1	0	NA	—		R/W
					Disable	Disables the CT function.	
					Enable	Enables the CT function.	
X.13	CT Scaling A	0.00/5.00	0.01	NA	NA	Displayed result of the SMC-50 controller tuning feature determination of the scaling between external CT and the internal current measuring circuitry.	R
X.14	CT Scaling B						
X.15	CT Scaling C						
X.16	Phase Shift A	-12.5/12.5	0.00	Deg	NA	Displayed result of the SMC-50 controller tuning feature determination of the phase shift between external CT and the internal current measuring circuitry.	R
X.17	Phase Shift B						
X.18	Phase Shift C						
X.19	Parameter Mgmt	0/1	0	NA	—		R/W
					Ready	Waiting for command to set defaults.	
					Factory Default	Set all writable parameters to factory default values.	

(1) X indicates the Control Module port number in which the 150-SM2 PTC, Ground Fault, and External CT Option Module is installed. Allowable ports = 7 or 8.

150-SM3 Analog I/O Module Information

Table 159 - Parameter X.1...X.56

No. ⁽¹⁾	Name	Min./Max. Values	Default Value	Units	Enum Text	Description	Read/Write Access
X.1	Module Status	0/4096	0	NA	—	Displays information about the operational status of the 150-SM3 Analog I/O Option Module	R
					Ready	Bit 0 = Ready Bit Set = indicates the module is ready for operation	
					In1 Over Flt	Bit 1 = Input 1 Over Fault Bit Set = Input 1 Overrange fault	
					In1 Over Alm	Bit 2 = Input 1 Over Alarm Bit Set = Input 1 Overrange alarm	
					In1 Undr Flt	Bit 3 = Input 1 Under Fault Bit Set = Input 1 Underrange fault	
					In1 Undr Alm	Bit 4 = Input 1 Under Alarm Bit Set = Input 1 Underrange Alarm	
					In2 Over Flt	Bit 5 = Input 2 Over Fault Bit Set = Input 2 Overrange fault	
					In2 Over Alm	Bit 6 = Input 2 Over Alarm Bit Set = Input 2 Overrange alarm	
					In2 Undr Flt	Bit 7 = Input 2 Under Fault Bit Set = Input 2 Underrange fault	
					In2 Undr Alm	Bit 8 = Input 2 Under Alarm Bit Set = Input 2 Underrange Alarm	
					Out 1 Shorted	Bit 9 = Output 1 Shorted Bit Set = indicates Output 1 is shorted	
					Out 1 Open	Bit 10 = Output 1 Open Bit Set = indicates Output 1 is an open circuit	
					Out 2 Shorted	Bit 11 = Output 2 Shorted Bit Set = indicates Output 2 is shorted	
					Out 2 Open	Bit 12 = Output 2 Open Bit Set = indicates Output 2 is an open circuit	
	Bits 13...15	Reserved					
X.2	Sample Rate	0/1	0	NA	60 Hz 250 Hz	Selects a 60 Hz filter on Input 1 and Input 2 Selects a 250 Hz filter on Input 1 and Input 2	R/W
X.3	Input 1 Scaled	-3000.0/3000.0	0.0	NA	NA	Input 1 scaled to user units	R
X.4	Input 1 Analog	-21.000/21.000	0.000	V or mA	NA	Input 1 in electrical units (volts or milliamps)	R
X.5	Input 1 Percent	-105.00/105.00	0.00	NA	NA	Input 1 as a percentage of configured range	R
X.6	Input 1 Raw	-32768/32768	0	NA	NA	Input 1 unscaled	R
X.7	Input 1 Range	0/5	1	NA	±10V	Input 1 set to voltage mode with range of -10V to +10V	R/W
					10V	Input 1 set to voltage mode with range of 0V to 10V	
					5V	Input 1 set to voltage mode with range of 0V to 5V	
					1...5V	Input 1 set to voltage mode with range of 1V to 5V	
					0...20 mA	Input 1 set to current mode with range of 0mA to 20mA	
4...20 mA	Input 1 set to current mode with range of 4mA to 20mA						
X.8	Input 1 Offset	-10000/10000	0	NA	NA	Offset value of Input 1 subtracted from the Input 1 Raw value (positive offset lowers the resulting value)	R/W
X.9	Input 1 Data Hi	-3000.0/3000.0	1000.0	NA	NA	User defined maximum value of Input 1 custom value range	R/W
X.10	Input 1 Data Lo	-3000.0/3000.0	0.0	NA	NA	User defined minimum value of Input 1 custom value range	R/W
X.11	Input 1 High	-21.000/21.000	10.000	V or mA	NA	Correlates Input 1 Data Hi to the Input 1 Raw value	R/W
X.12	Input 1 Low	-21.000/21.000	0.000	V or mA	NA	Correlates Input 1 Data Low to the Input 1 Raw value	R/W
X.13	Input 2 Scaled	-3000.0/3000.0	0.0	NA	NA	Input 2 scaled to user units	R
X.14	Input 2 Analog	-21.000/21.000	0.000	V or mA	NA	Input 2 in electrical units (volts or milliamperes)	R
X.15	Input 2 Percent	-105.00/105.00	0.00	NA	NA	Input 2 as a percentage of configured range	R
X.16	Input 2 Raw	-32768/32768	0	NA	NA	Input 2 unscaled	R

No.(1)	Name	Min./Max. Values	Default Value	Units	Enum Text	Description	Read/Write Access
X.17	Input 2 Range	0/5	1	NA	±10V	Input 2 set to voltage mode with range of -10V to +10V	R/W
					10V	Input 2 set to voltage mode with range of 0V to 10V	
					5V	Input 2 set to voltage mode with range of 0V to 5V	
					1...5V	Input 2 set to voltage mode with range of 1V to 5V	
					0...20 mA	Input 2 set to current mode with range of 0mA to 20mA	
					4...20 mA	Input 2 set to current mode with range of 4mA to 20mA	
X.18	Input 2 Offset	-10000/10000	0	NA	NA	Offset value of Input 2 subtracted from the Input 2 Raw value. (positive offset lowers the resulting value)	R/W
X.19	Input 2 Data Hi	-3000.0/3000.0	1000.0	NA	NA	User defined maximum value of Input 2 custom value range	R/W
X.20	Input 2 Data Lo	-3000.0/3000.0	0.0	NA	NA	User defined minimum value of Input 2 custom value range	R/W
X.21	Input 2 High	-21.000/21.000	10.000	V or mA	NA	Correlates Input 2 Data Hi to the Input 2 Raw value	R/W
X.22	Input 2 Low	-21.000/21.000	0.000	V or mA	NA	Correlates Input 2 Data Low to the Input 2 Raw value	R/W
X.23	Output 1 Range	0/4	1	NA	±10V	Output 1 set to voltage mode with range of -10V to +10V	R/W
					10V	Output 1 set to voltage mode with range of 0V to 10V	
					5V	Output 1 set to voltage mode with range of 0V to 5V	
					0...20 mA	Output 1 set to current mode with range of 0mA to 20mA	
					4...20 mA	Output 1 set to current mode with range of 4mA to 20mA	
X.24	Output 1 Select	0/15999	1	NA	NA	Selects the parameter used to drive Output 1	R/W
X.25	Output 1 High	-20.000/20.000	10.000	V or mA	NA	Output level when the selected parameter (Output 1 Select) reaches "Output 1 Data Hi"	R/W
X.26	Output 1 Low	-20.000/20.000	0.000	V or mA	NA	Output level when the selected parameter (Output 1 Select) reaches "Output 1 Data Lo"	R/W
X.27	Output 1 Data Hi	-300000000/300000000	480	V or mA	NA	Level of the selected parameter (Output 1 Select) corresponding to an output of "Output 1 High"	R/W
X.28	Output 1 Data Lo	-300000000/300000000	0	V or mA	NA	Level of the selected parameter (Output 1 Select) corresponding to an output of "Output 1 High"	R/W
X.29	Output1 Setpoint	0/65535	0	NA	NA	Raw value sent to Output 1 when "Output 1 Select" is set to "Disabled"	R/W
X.30	Output 2 Range	0/4	1	NA	±10V	Output 2 set to voltage mode with range of -10V to +10V	R/W
					10V	Output 2 set to voltage mode with range of 0V to 10V	
					5V	Output 2 set to voltage mode with range of 0V to 5V	
					0...20 mA	Output 2 set to current mode with range of 0mA to 20mA	
					4...20 mA	Output 2 set to current mode with range of 4mA to 20mA	
X.31	Output 2 Select	0/15999	1	NA	NA	Selects the parameter used to drive Output 2	R/W
X.32	Output 2 High	-20.000/20.000	10.000	V or mA	NA	Output level when the selected parameter (Output 2 Select) reaches "Output 2 Data Hi"	R/W
X.33	Output 2 Low	-20.000/20.000	0.000	V or mA	NA	Output level when the selected parameter (Output 2 Select) reaches "Output 2 Data Lo"	R/W
X.34	Output 2 Data Hi	-300000000/300000000	480	V or mA	NA	Level of the selected parameter (Output 2 Select) corresponding to an output of "Output 2 High"	R/W
X.35	Output 2 Data Lo	-300000000/300000000	0	V or mA	NA	Level of the selected parameter (Output 2 Select) corresponding to an output of "Output 2 High"	R/W
X.36	Output2 Setpoint	0/65535	0	NA	NA	Raw value sent to Output 2 when "Output 2 Select" is set to "Disabled"	R/W
X.37	Fault Enable	0/255	0	NA	In1 Over	Lets you enable the Input/Output faults 0 = Fault Disabled 1 = Fault Enabled	R/W
					In1 Under		
					In2 Over		
					In2 Under		
					Out1 Shorted		
					Out1 Open		
					Out2 Shorted		
					Out2 Open		

No. ⁽¹⁾	Name	Min./Max. Values	Default Value	Units	Enum Text	Description	Read/Write Access
X.38	Alarm Enable	0/255	0	NA	In1 Over	Lets you enable the Input/Output alarms 0 = Alarm Disabled 1 = Alarm Enabled	R/W
					In1 Under		
					In2 Over		
					In2 Under		
					Out1 Shorted		
					Out1 Open		
					Out2 Shorted		
					Out2 Open		
X.39	Restart Enable	0/255	0	NA	In1 Over	0 = Do not attempt a restart after fault is cleared 1 = Attempt a restart after fault is cleared Note: Restart Attempts, Parameter 133 and Restart Delay, Parameter 134 must also be configured	R/W
					In1 Under		
					In2 Over		
					In2 Under		
					Out1 Shorted		
					Out1 Open		
					Out2 Shorted		
					Out2 Open		
X.40	In1 Over F Lvl	-3000.0/3000.0	1050.0	NA	NA	If Input 1 exceeds this level for the time period set in the In1 Over F Dly parameter, an In1 Over fault is signaled. The In1 Over bit must be set in the Fault Enable Parameter	R/W
X.41	In1 Over F Dly	0.1/99.0	3.0	sec	NA	The time period that Input 1 must exceed the In1 Over F Lvl to signal a fault. The In1 Over bit must be set in the Fault Enable Parameter	R/W
X.42	In1 Over A Lvl	-3000.0/3000.0	1000.0	NA	NA	If Input 1 exceeds this level for the time period set in the In1 Over A Dly parameter, an In1 Over alarm is signaled. The In1 Over bit must be set in the Alarm Enable Parameter	R/W
X.43	In1 Over A Dly	0.1/99.0	3.0	sec	NA	The time period that Input 1 must exceed the In1 Over F Lvl to signal a fault. The In1 Over bit must be set in the Fault Enable Parameter.	R/W
X.44	In1 Under F Lvl	-3000.0/3000.0	-50.0	NA	NA	If Input 1 remains below this level for the time period set in the In1 Under F Dly parameter, an In1 Under fault is signaled. The In1 Under bit must be set in the Fault Enable Parameter	R/W
X.45	In1 Under F Dly	0.1/99.0	3.0	sec	NA	The time period that Input 1 must remain below the In1 Under F Lvl to signal a fault. The In1 Under bit must be set in the Fault Enable Parameter	R/W
X.46	In1 Under A Lvl	-3000.0/3000.0	0.0	NA	NA	If Input 1 remains below this level for the time period set in the In1 Under A Dly parameter, an In1 Under alarm is signaled. The In1 Under bit must be set in the Alarm Enable Parameter	R/W
X.47	In1 Under A Dly	0.1/99.0	3.0	sec	NA	The time period that Input 1 must remain below the In1 Under F Lvl to signal a fault. The In1 Under bit must be set in the Fault Enable Parameter.	R/W
X.48	In2 Over F Lvl	-3000.0/3000.0	1050.0	NA	NA	If Input 2 exceeds this level for the time period set in the In2 Over F Dly parameter, an In2 Over fault is signaled. The In2 Over bit must be set in the Fault Enable Parameter	R/W
X.49	In2 Over F Dly	0.1/99.0	3.0	sec	NA	The time period that Input 2 must exceed the In2 Over F Lvl to signal a fault. The In2 Over bit must be set in the Fault Enable Parameter	R/W
X.50	In2 Over A Lvl	-3000.0/3000.0	1000.0	NA	NA	If Input 2 exceeds this level for the time period set in the In2 Over A Dly parameter, an In2 Over alarm is signaled. The In2 Over bit must be set in the Alarm Enable Parameter	R/W
X.51	In2 Over A Dly	0.1/99.0	3.0	sec	NA	The time period that Input 2 must exceed the In2 Over F Lvl to signal a fault. The In2 Over bit must be set in the Fault Enable Parameter	R/W
X.52	In2 Under F Lvl	-3000.0/3000.0	-3000.0/3000.0	NA	NA	If Input 2 remains below this level for the time period set in the In2 Under F Dly parameter, an In2 Under fault is signaled. The In2 Under bit must be set in the Fault Enable Parameter	R/W
X.53	In2 Under F Dly	0.1/99.0	0.1/99.0	sec	NA	The time period that Input 2 must remain below the In2 Under F Lvl to signal a fault. The In2 Under bit must be set in the Fault Enable Parameter	R/W
X.54	In2 Under A Lvl	-3000.0/3000.0	-3000.0/3000.0	NA	NA	If Input 2 remains below this level for the time period set in the In2 Under A Dly parameter, an In2 Under alarm is signaled. The In2 Under bit must be set in the Alarm Enable Parameter	R/W

No. ⁽¹⁾	Name	Min./Max. Values	Default Value	Units	Enum Text	Description	Read/Write Access
X.55	In2 Under A Dly	0.1/99.0	0.1/99.0	sec	NA	The time period that Input 2 must remain below the In2 Under F Lvl to signal a fault. The In2 Under bit must be set in the Fault Enable Parameter	R/W
X.56	Parameter Mgmt	0/1	0/1	NA	Ready	Waiting for command to set defaults	R/W
					Set Defaults	Set all writable parameters to factory default values	

(1) X indicates the Control Module port number in which the Cat. No. 150-SM3 Analog I/O option module is installed. Allowable ports = 7 or 8.

Option Modules

Introduction

The SMC-50 controller has three expansion ports for optional modules. These ports let you add control modules (such as additional inputs and outputs (I/O), simple start/stop parameter configuration capability, and ground fault). Brief functional explanations are provided here with the wiring termination identifications. See [Chapter 6](#) for more detailed functional and configuration information. See [Figure 103](#) for compatible port locations of the selected module.



ATTENTION: There is the potential to have voltage values above 220V AC on the option modules. Before removing the control module cover to access option modules, disconnect ALL power to the SMC-50 Controller.

Figure 103 - Port Number Identification

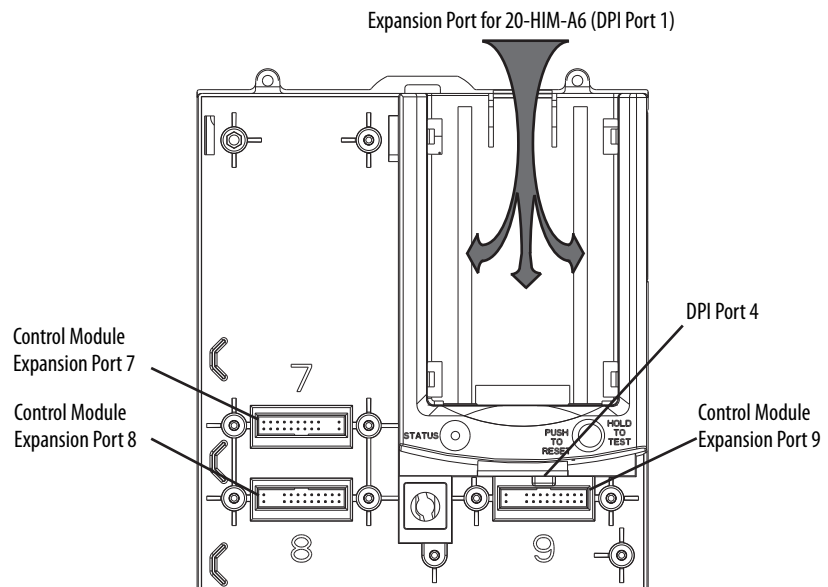

Table 160 - Port Location for Compatible Option Modules

SMC-50 Control Module Compatible Option Modules Cat. Nos.	Compatible Control Module Port			Maximum Number of this Type of Option Module per Control Module
	Port 7	Port 8	Port 9	
150-SM2: Ground Fault/PTC/External CT	Yes	Yes	No	1
150-SM3: Analog I/O	Yes	Yes	Yes	3
150-SM4: Digital I/O	Yes	Yes	Yes	3
150-SM6: Parameter Configuration	Yes	Yes	Yes	1
20-COMM-X ^{(1) (2)} Communications	No	No	Yes	1

(1) See [Chapter 9](#) for a list of compatible 20-COMM-X modules.

(2) When installed in an SMC-50 controller, 20-COMM-X modules physically reside in the space assigned to Port 9, but connects to DPI Port 4 with the ribbon cable that is supplied with the module.

Cat. No. 150-SM4 Digital I/O Module

A Cat. No. 150-SM4 Digital I/O Option Module provides four 120...240V AC digital on/off inputs and three relay outputs to provide additional auxiliary control or indications (e.g., up-to-speed (UTS), alarm, etc.) functions. The 150-SM4 module can be located in any of the three control module option ports (See [Figure 103](#)). Up to three 150-SM4 modules can be used with a single control module. The 150-SM4 module terminal block used to wire the I/O is removable.

TIP When installed in Control Module Port 7, the orientation of the module terminal block is rotated 180° along with its terminals.

The Cat. No. 150-SM4 Digital I/O Module can NOT be configured using a 150-SM6 PCM. This module can be configured using a 20-HIM-A6, network card, or communications software.

Figure 104 - Optional Digital I/O Module Terminal Identification

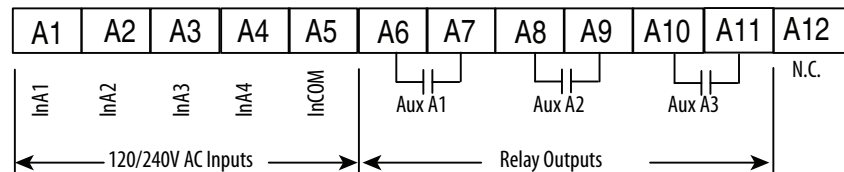

Terminal Number	Description
A1 ⁽¹⁾	Optional Input #1 (120/240V AC)
A2 ⁽¹⁾	Optional Input #2 (120/240V AC)
A3 ⁽¹⁾	Optional Input #3 (120/240V AC)
A4 ⁽¹⁾	Optional Input #4 (120/240V AC)
A5 ⁽²⁾	Input Common
A6 ⁽²⁾⁽³⁾	Optional Auxiliary Relay Contact #1
A7 ⁽²⁾⁽³⁾	Optional Auxiliary Relay Contact #1
A8 ⁽²⁾⁽³⁾	Optional Auxiliary Relay Contact #2
A9 ⁽²⁾⁽³⁾	Optional Auxiliary Relay Contact #2
A10 ⁽²⁾⁽³⁾	Optional Auxiliary Relay Contact #3
A11 ⁽²⁾	Optional Auxiliary Relay Contact #3
A12	NO CONNECT

(1) Do not connect additional loads to this terminal. Parasitic loads may cause problems with operation.

(2) RC snubbers are required when inductive loads are connected to terminal.

(3) When set to external bypass mode, the auxiliary contact is used to control a properly sized external contactor and overload once the motor is at full speed.

Optional Cat. No. 150-SM3 Analog I/O Module

An optional Cat. No. 150-SM3 Analog I/O Module provides two analog inputs (voltage or current) and two analog outputs (voltage or current).

The 150-SM3 module can be located in any of the three control module option ports (See [Figure 103](#)). You can use up to three 150-SM3 modules with a single control module. The 150-SM3 module terminal block used to wire the I/O is removable.

TIP When installed in Control Module Port 7, the orientation of the module terminal block is rotated 180° along with its terminals.

The Cat. No. 150-SM3 Analog I/O Module can NOT be configured using a 150-SM6 PCM. This module can be configured using a 20-HIM-A6, network card, or communications software.

Figure 105 - Analog I/O Module Wiring Diagram

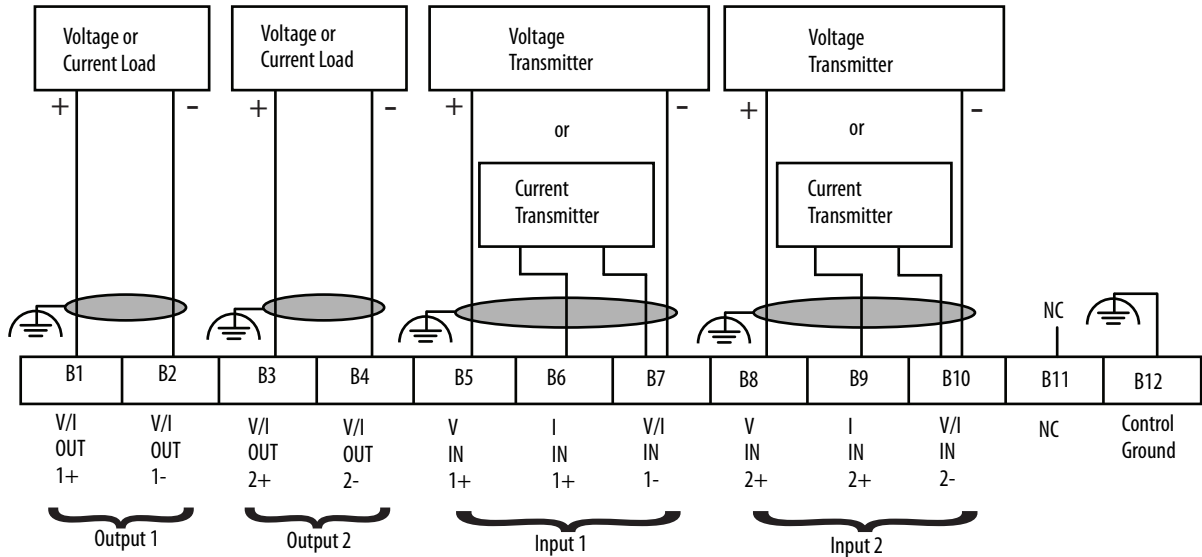

Cat. No. 150-SM2 Positive Temperature Coefficient (PTC), Ground-Fault, and External Current Transformer Option Module

An optional Cat. No. 150-SM2 module provides connectivity to external PTC motor winding temperature sensors, ground-fault, and current transformer sensors.

The 150-SM2 module can be located in control module Port 7 or 8. Only one 150-SM2 module can be used with the control module (See [Figure 103](#)). All of the individual terminal blocks (TB2, TB3, and TB4) are removable. The RG25U female connector provides a connection point for the male-to-male cable provided with the 825-MCM current sensor/converter module.

TIP When installed in Control Module Port 7, the orientation of the module terminal block is rotated 180° along with its terminals.

The Cat. No. 150-SM2 Option Module can NOT be configured using a 150-SM6 PCM. This module can be configured using a 20-HIM-A6, network card, or communications software.

Figure 106 - 150-SM2 Circuit Board

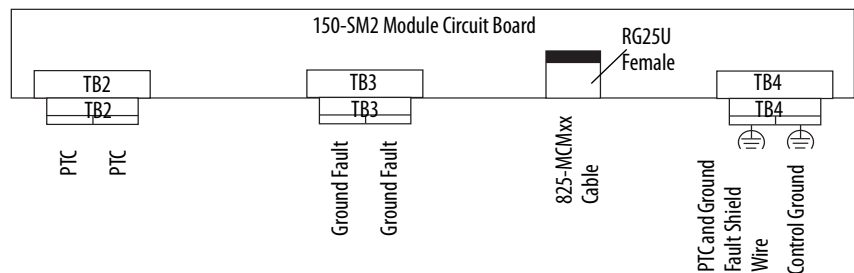

Positive Temperature Coefficient (PTC) Sensor — Motor Temperature Sensing:

The optional 150-SM2 module lets the SMC-50 controller interface with motor PTC sensors. It is common for motor manufacturers to embed PTC thermistor sensors in motor stator windings to provide temperature monitoring of the motor windings. Because PTC thermistor sensors react to the actual motor winding temperature, enhanced motor protection can be provided to address conditions like obstructed motor cooling and high ambient temperature. [Table 161](#) defines the required PTC thermistor input and response ratings for operation with the 150-SM2 module.

Table 161 - PTC Thermistor Input & Response Ratings

Thermistor Input	Response Ratings
Response Resistance:	3400 Ω ± 150 Ω
Reset Resistance:	1600 Ω ± 100 Ω
Short-circuit Trip Resistance:	25 Ω ± 10 Ω
Maximum Voltage at PTC Terminals: (RPTC = 4 K ohms):	< 7.5V
Maximum Voltage at PTC Terminals: (RPTC = open):	30V
Maximum Number of Sensors Connected in Series:	6
Maximum Cold Resistance of PTC Sensor Chain:	1500 Ω
Response Time:	800 ms

[Figure 107](#) shows the required PTC sensor characteristics for operation with the 150-SM2 Option Module, per IEC-34-11-2.

Figure 107 - PTC Sensor Characteristics per IEC-34-11-2

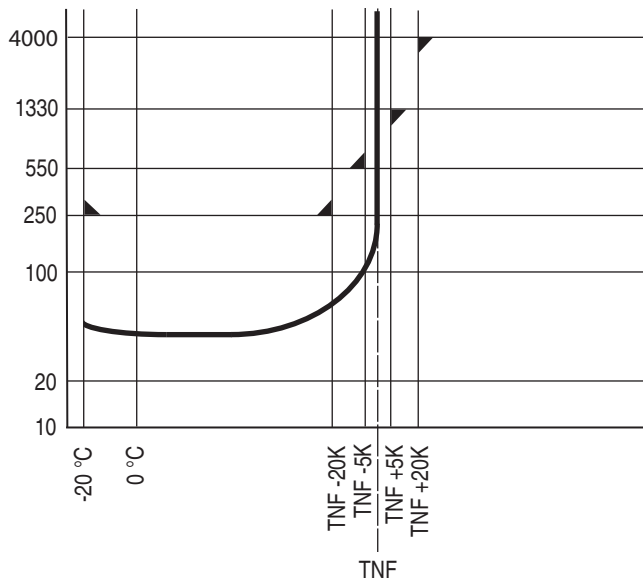

For additional information concerning the configuration and diagnostic information provided by the PTC part of the 150-SM2 Option Module, see [Chapter 6, Programming](#).

Ground Fault Sensing

In isolated or high impedance-grounded systems, core-balanced current sensors are typically used to detect low-level ground faults that could be due to motor insulation breakdown or entry of foreign objects. Detection of ground faults can prevent further damage or alert personnel to perform maintenance.

The SMC-50 controller can provide ground fault indication when you use it with the 150-SM2 Option Module and the 825-CBCT External Ground Fault (Core Balance) Current Sensor. The ground fault current sensor mounts separately from the SMC-50 controller and must be placed within three meters of the SMC-50 controller. A customer-supplied cable for wiring the ground fault sensor to the 150-SM2 module must meet the requirements outlined in [Table 162](#).



ATTENTION: The ground fault sensing feature of the SMC-50 controller is intended for monitoring purposes only. It is not intended as a ground fault circuit interrupter for personnel protection as defined in Article 100 of the National Electric Code (NEC) and has not been evaluated to UL 1053.

Table 162 - Ground Fault Sensor Cable Requirements

Wire Type ⁽¹⁾ :	Shielded, twisted pair
Wire Size:	0.2...2.5 mm ² (#24...14 AWG)
Terminal Torque:	0.8 N·m (7.0 lb·in.)

(1) See [Figure 111 on page 286](#) for wiring details.

Figure 108 - 825-CBCT Dimensions

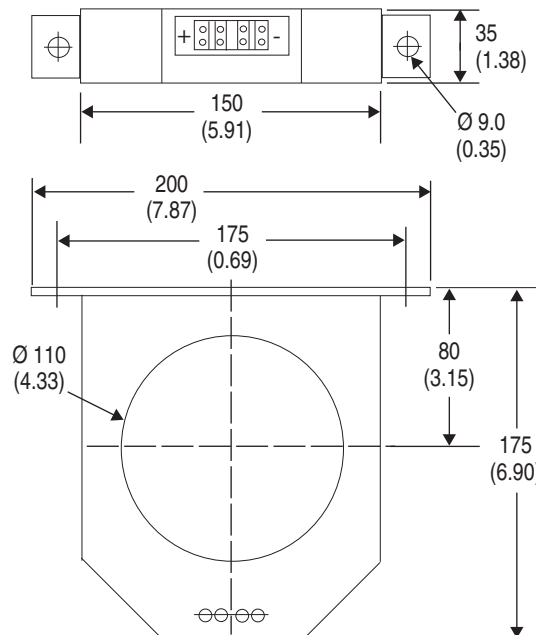

External Current Transformer — Current Sensing in Bypass Mode

The 150-SM2 Option Module and an external current sensing device such as an 825-MCM converter can be used to provide current feedback to the SMC-50 controller when it is used with an external bypass contactor. The external current feedback device provides all current measurement and current protection functions while the controller is in external bypass mode (running). A single 825-MCM converter provides external current feedback from all three motor phases. In all other modes (starting, stopping, slow speed, etc.), the SMC-50 controller’s internal current feedback signals are used.

TIP External current transformers (CTs) can be used and enabled even without an external bypass.

[Table 163](#) shows which 825 converter to use based on the motor FLC range.

Table 163 - 825 Converter Selection

Motor FLC Range	Catalog Number
30...180 A	825-MCM180
181...520 A	825-MCM20 ⁽¹⁾

(1) User-supplied current transformers with 5 A secondary are required. See [Figure 109](#).

Figure 109 - Current Transformer Connection to Converter Module

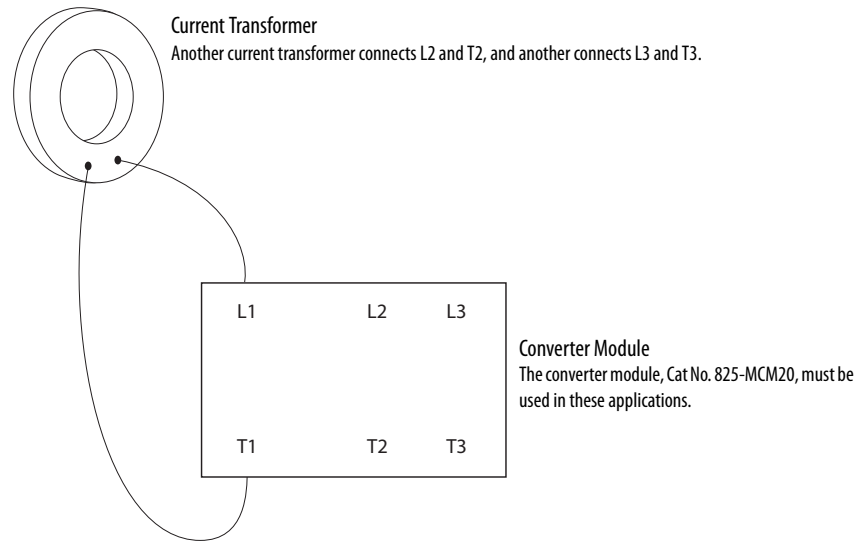

To enable the 150-SM2 External CT function, the CT Enable parameter in the 150-SM2 must be set to "Enable" and the 825-MCM hardware must be correctly configured. When the 150-SM2 External CT function is enabled, the SMC-50 controller calibrates the external CT for scaling, phase shift, and inversion during the SMC-50 controller tuning cycle. The tuning cycle will automatically occur before the first start after the controller installation, after a "Load Default" parameter occurs, or when you force tuning of the SMC-50 controller through the Force Tuning parameter or the control module’s Hold to Reset button. The scaling is displayed relative to the unit’s rating where 1.00 indicates that the external CTs and the internal CTs are scaled the same.

[Figure 110](#) shows the connection of the 825-MCM Converter to the SMC-50 controller's 150-SM2 Option Module.

Figure 110 - Converter to Option Module Connection

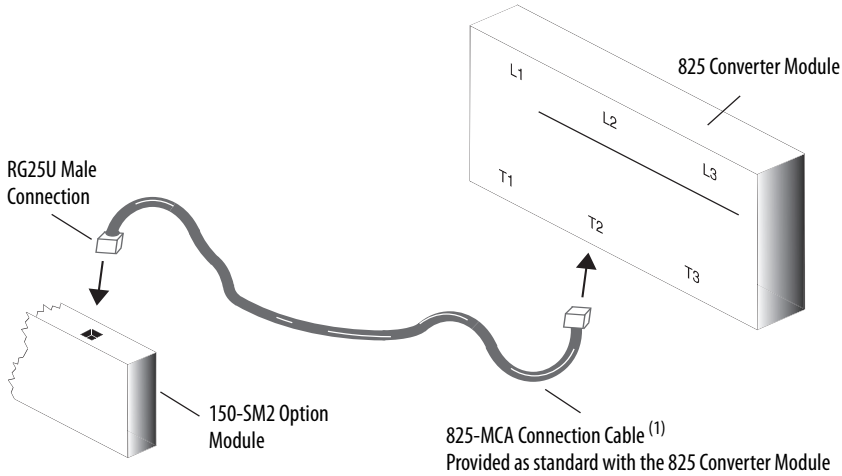

(1) The cable length is fixed at 4 meters. Only the cable provided with the converter can be used. The use of any other cable will result in incorrect data from the converter and incorrect controller operation.

[Table 164](#) provides the terminal and wire specifications for the 150-SM2 (terminals TB2, TB3, and TB4).

Table 164 - Control and Option Module Wiring Specifications

Wire Size	0.2...2.5 mm ² (#24...14 AWG)
Maximum Torque	0.8 N·m (7 lb·in.)
Maximum Wire Strip Length	7 mm (0.27 in.)
Screw Type	M3 Slotted

[Figure 111](#) provides information for wiring all sensors to the 150-SM2 module.

Figure 111 - Combined Wiring Diagram of all 150-SM2 Sensors

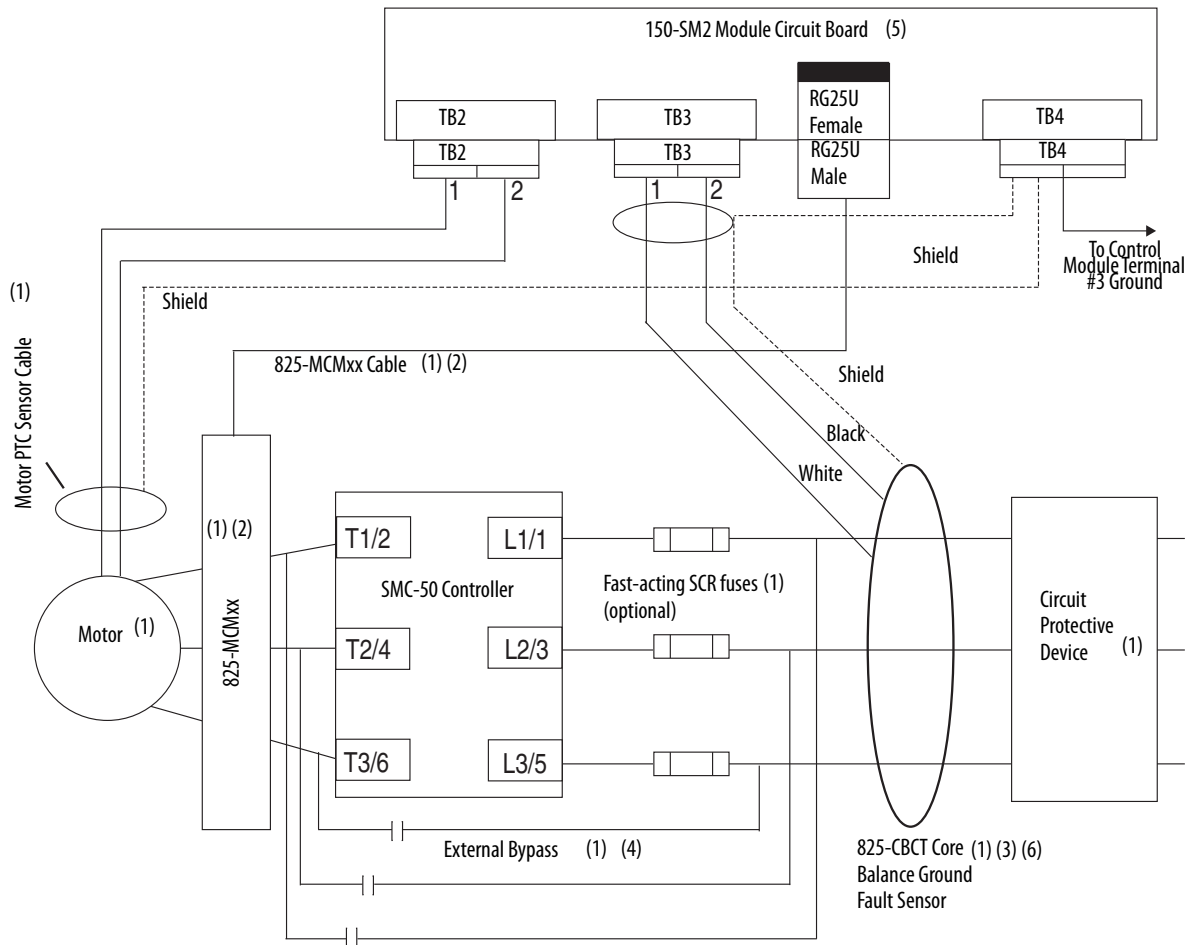

- (1) Customer supplied.
- (2) The 825-MCM can be used with or without an external bypass contactor. If an external bypass contactor is used then the 825-MCM must be installed in order to use current-based motor protective features including the motor overload feature. Cable length is 4 meters. Only the cable provided with the 825-MCM is compatible with the 150-SM2. See Figure 112 for 825-MCM dimensions.
- (3) The 825-CBCT Core Balance Sensor mounts separately from the SMC-50 controller and must be placed within 3 meters of the SMC-50 controller. When connecting the 825-CBCT ground-fault sensor, the secondary of the CT must be shorted until connection to the 150-SM2 module is complete.
- (4) See Figure 42 on page 64 for additional bypass configurations (such as emergency run-off bypass) and application considerations.
- (5) To meet product susceptibility requirements, a single ferrite core must be placed around any or all sensor (such as, PTC, ground fault, etc.) wires connected to the 150-SM2 Option Module. The recommended core is a Fair-Rite Products Corp Part Number 0431167281 or equivalent.
- (6) Ensure the 150-SM2 Turns Ratio, Parameter X.5, is configured to match the 825-CBCT Turns Ratio 100:1 (X.5=100).

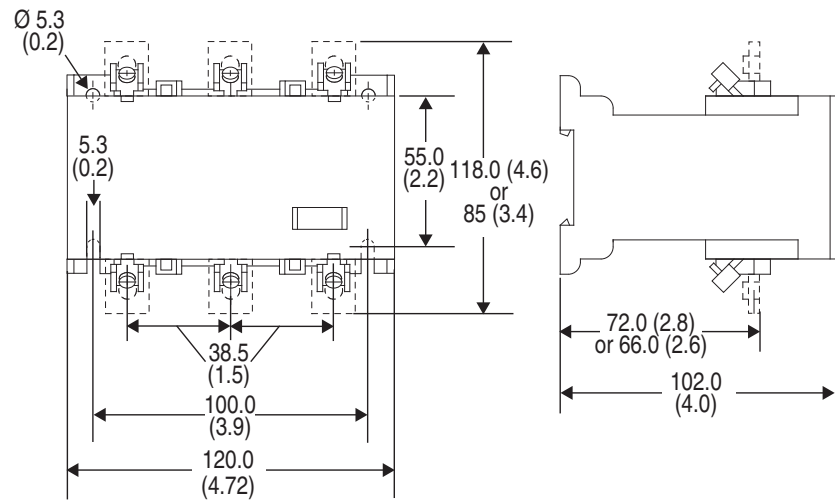
Figure 112 - 825-MCM180 and -MCM20 Dimensions

Cat. No. 150-SM6 Parameter Configuration Module (PCM)

The Cat. No. 150-SM6 PCM provides simple and limited configuration of the SMC-50 controller. You can insert this PCM into any control module option port (7, 8, or 9).

This module contains five rotary dials and three banks of two-position, eight-switch DIP switches.

Parameters that **are** configured by the PCM will appear as read-write parameters to other configuration devices whose values represent the switch settings. The parameter values set by the PCM are stored in the control module memory. If any of these parameters are changed by an external device, the value will revert to the PCM setting.

Parameters that **are not** defined and therefore are not configurable by the PCM can be configured through other means (like Human Interface Module (HIM), Connected Components Workbench software, or DriveExecutive software), if necessary.

Only one 150-SM6 Option Module can be installed in the control module. Any of the three control module expansion ports can be used. A fault is generated if you attempt to install more than one 150-SM6 into the control module.

You can use a single PCM to configure multiple SMC-50 controllers. After setup of the initial SMC-50 controller is complete, remove all power and move the PCM to the next SMC-50 controller that needs to be programmed. Upon powerup of the initial SMC-50 controller, the parameters set by the PCM are retained.

Notes:

Using DeviceLogix

Introduction

DeviceLogix is a standard feature in the SMC-50 controller (firmware 4.002 and higher). DeviceLogix can be used to control and monitor the SMC-50 controller. Program DeviceLogix for the SMC-50 controller through a DeviceLogix Editor component ( icon), available in Connected Components Workbench software version 6 and later. You cannot use other DeviceLogix Editors, such as RSNNetWorx for DeviceNet.

Table 165 - Basic features:

	SMC-50 controller 4.002 and later
DeviceLogix Library	Version 5
Maximum number of function blocks	32
Program update time per number of blocks used	20 ms (fixed): 1...10 blocks 30 ms (fixed): 11...21 blocks 40 ms (fixed): 22...32 blocks

The SMC-50 controller DeviceLogix implementation provides basic logic capability for applications. A 20...40 ms scan time is provided depending on program size. You can use DeviceLogix in both networked and stand-alone environments. DeviceLogix continues execution independent of the SMC-50 controller's state (such as starting, running, fault)

There is no data retention in DeviceLogix during a power cycle. Timer and counter accumulators, calculation results, latched bits, etc. are cleared.

Controlling the SMC-50 controller operating modes (starting, stopping, slow speed etc.) through DeviceLogix requires you to set bit #14 of the "Logic Mask" (parameter #148).

Parameters

See [Table 155 on page 268](#) for DeviceLogix parameter descriptions.

Function Block Elements

The following function block elements are available:

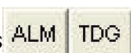
- Bit and Analog I/O⁽¹⁾ 
- Process 

(1) Bit and Analog I/O do not count against the Function Block total. All other elements count, with each instance counting as one Function Block.

- Select/Limit

SEL	HLL
-----	-----

- Timer/Counter

TONR	TOFR	PULR	CTU	CTD	CTUD
------	------	------	-----	-----	------

- Compare

MEQ	EQU	NEQ	LES	GRT	LEQ	GEQ
-----	-----	-----	-----	-----	-----	-----

- Compute/Math

ADD	SUB	MUL	DIV	MOD	NEG	ABS
-----	-----	-----	-----	-----	-----	-----

- Move/Logical

BAND	BOR	BXOR	BNOT	BRAND	BNOR	BXNOR	SETD	RSTD
------	-----	------	------	-------	------	-------	------	------

- Macro Block

--

The DeviceLogix Editor provides a graphical interface for configuring Function Blocks to provide local control within the drive. DeviceLogix Editor navigation and programming basics are not covered in this manual. Refer to the DeviceLogix user manual, publication [RA-UM003](#) for additional information.

Macro Blocks | | |--| | | |--|

You can create up to five Macro Blocks and you can use each five times. The selections are empty until you create a Macro Block. You also create the icon text associated with each Macro Block.

Bit and Analog I/O Points

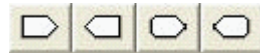

The DeviceLogix controller in Port 14 uses (32) bit inputs, (18) bit outputs, (24) analog inputs, and (2) analog outputs.

Bit Inputs

Available bit inputs to the DeviceLogix program include:

Bit Inputs	Name	Description
(17) Hardware Boolean Inputs	Input 1, Input 2	State of the 2 inputs on the control module.
	P7 Ready, P8 Ready, P9 Ready	Status indicating that the expansion card installed into the corresponding expansion port is functioning and Ready
	PX input 1 – PX input 4	Status of the Boolean inputs from the expansion cards – See the Expansion Card Mapping table below
(15) Network Boolean Inputs	Running Phase Rotation Phase Detection Starting Stopping Alarm Fault At Speed Start Bypass Ready	These Boolean inputs correspond to the statuses listed in Table 117 on page 220
	Network Bit 1 Network Bit 2 Network Bit 3 Network Bit 4	These Boolean inputs correspond to the statuses listed in Table 118 on page 221

The function of the expansion port inputs depends on the card installed in the given port. [Table 166](#) shows how the bit inputs are mapped for each card type:

Table 166 - Bit Input Mapping

Bit Input	Digital I/O (150-SM4)	Analog I/O (150-SM3)	PTC / Ground Fault (150-SM2)	Parameter Config (150-SM6)
PX Input 1	Input #1	DAC #1 Open Status	PTC Status	None (always 0)
PX Input 2	Input #2	DAC #1 Shorted Status	CT Loss Status	None (always 0)
PX Input 3	Input #3	DAC #2 Open Status	None (always 0)	None (always 0)
PX Input 4	Input #4	DAC #1 Shorted Status	None (always 0)	None (always 0)

Bit Outputs

Bit Outputs are used to connect to real-world output devices (pilot lights, relays, etc.) that are wired to an auxiliary relay in the SMC-50 controller. Available bit outputs are shown in [Table 167](#).

Table 167 - Bit Output Mapping

Bit Outputs	Name	Description
(11) Hardware Boolean Outputs	Aux 1, Aux2	Auxiliary Relays available on the control board. ⁽¹⁾ ?
	PX Aux1 – PX Aux3	Auxiliary Relays #1 - #3 available on the Digital I/O (150-SM4) Expansion Card ⁽¹⁾
(7) Network Boolean Outputs	Coast Start Stop CLR Fault Slow Speed Emergency Run Motor Heater	These outputs can be used to control the SMC-50 controller in the same way a PLC can control the SMC-50 controller. See Table 118 on page 221 for a definition of these control bits.

(1) The Auxiliary Relays must be programmed to "Device Logix" to allow the DeviceLogix program to control each specific relay. For example, if you want to control Aux 1 on the control module you must configure "Aux1 Config" (parameter #172) to "Device Logix". Similarly, to control Aux 1 in a Digital I/O (150-SM4) expansion card you must configure "Aux 1 Config" (parameter #6 in the expansion card) to "Device Logix".

Analog Inputs

Available analog inputs to the DeviceLogix program are all 32-bit integers and include the data points shown in [Table 168](#).

Table 168 - Analog Input Data Points

Analog Inputs	Name	Description
(22) Network Analog Inputs	Volt PP Ave	Average Phase to Phase Voltage (Param #1 - Volts)
	I Ave	Average Current (Param #5 – Amps)
	Torque	Average Torque (Param #9 - %)
	Real Power	Total Real Power (Param #10 – kWatts)
	Power Factor	Average Power Factor (Param #17 – in hundredths)
	Volt PN Ave	Average Phase to Neutral Voltage (Param #265 – Volts)
	Reactive Power	Total Reactive Power (Param #277 – kWatts)
	Apparent Power	Total Apparent Power (Param #286 – kWatts)
	DLX In 1, DLX In 2	DLX General-purpose Input parameters (Param #335, #336)
	DLX DL1 – DLX DL6	DLX Datalink Input Parameters (Param #337-342)
	PX In 1 – PX In 2	Analog inputs from the expansion cards – See Table 169

The function of the expansion port inputs depends on the card installed in the given port. [Table 169](#) shows how the analog inputs are mapped for each card type.

Table 169 - Expansion Card Input Mapping

Bit Input	Digital I/O (150-SM4)	Analog I/O (150-SM3)	PTC / Grd Fault (150-SM2)	Parameter Config (150-SM6)
PX In 1	None (always 0)	Analog In #1 (Param X.6)	Ground Current (Param #11)	None (always 0)
PX In 2	None (always 0)	Analog In #2 (Param X.16)	None (always 0)	None (always 0)

Analog Outputs

Available analog outputs from the DeviceLogix program are all 32-bit integers and include the data points in [Table 170](#).

Table 170 - Analog Output Data Points

Analog Outputs	Name	Description
(2) Network Analog Outputs	A Out 1 – A Out 2	General-purpose Output parameters (Param #343, #344)

Tips

Data Types

The SMC-50 controller DeviceLogix implementation supports 32-bit integers only.

DeviceLogix Scratchpad Registers

The SMC-50 controller provides 2 input (parameter #335, #336) and 2 output (parameter #343, #344) scratchpad registers. The input parameters can be written by any configuration or network device and used as an input to DeviceLogix. The output parameters can be written by DeviceLogix and displayed on configuration devices or read using network devices.

SMC-50 Controller DeviceLogix Input Datalinks (P337...P342)

The SMC-50 controller provides parameters directly to DeviceLogix as analog inputs. Additional parameters from the host and expansion cards can be made available through the DeviceLogix Datalink inputs. The value of the parameter linked to by the datalink is made available to DeviceLogix. For example, configuring a datalink to “Mtr Therm Usage” (parameter #18) would make the motor thermal usage value available to DeviceLogix.

Program Examples

Example 1: Selector Switch Operation

This example demonstrates how a selector switch could be used to select one or four parameters to write to one of the scratchpad output parameters.

[Table 171](#) represents the inputs and outputs for a 4 position selector switch.

Table 171 - Four-position Selector Switch I/O

Inputs		Outputs	
Input 1	Input 2	Output Selection	Selector Switch Output
0	0	0	Volt PP Ave
0	1	1	Volt Phase A-B
1	0	2	Volt Phase B-C
1	1	3	Volt Phase C-A

Parameter Configuration

Because the individual phase voltage parameters are not directly available in DeviceLogix (only the average voltage – Volt PP Ave is) we use three of the DeviceLogix Datalink parameters to make those values available to DeviceLogix as shown in [Table 172](#)

Table 172 - DeviceLogix Datalink Parameters

Parameter No.	Parameter	Value	Description
337	DLX DL Input 1	Port 0: Volts Phase A-B	Value for Selection 01
338	DLX DL Input 2	Port 0: Volts Phase B-C	Value for selection 10
339	DLX DL Input 3	Port 0: Volts Phase C-A	Value for selection 11

Figure 113 - Function Block Programming

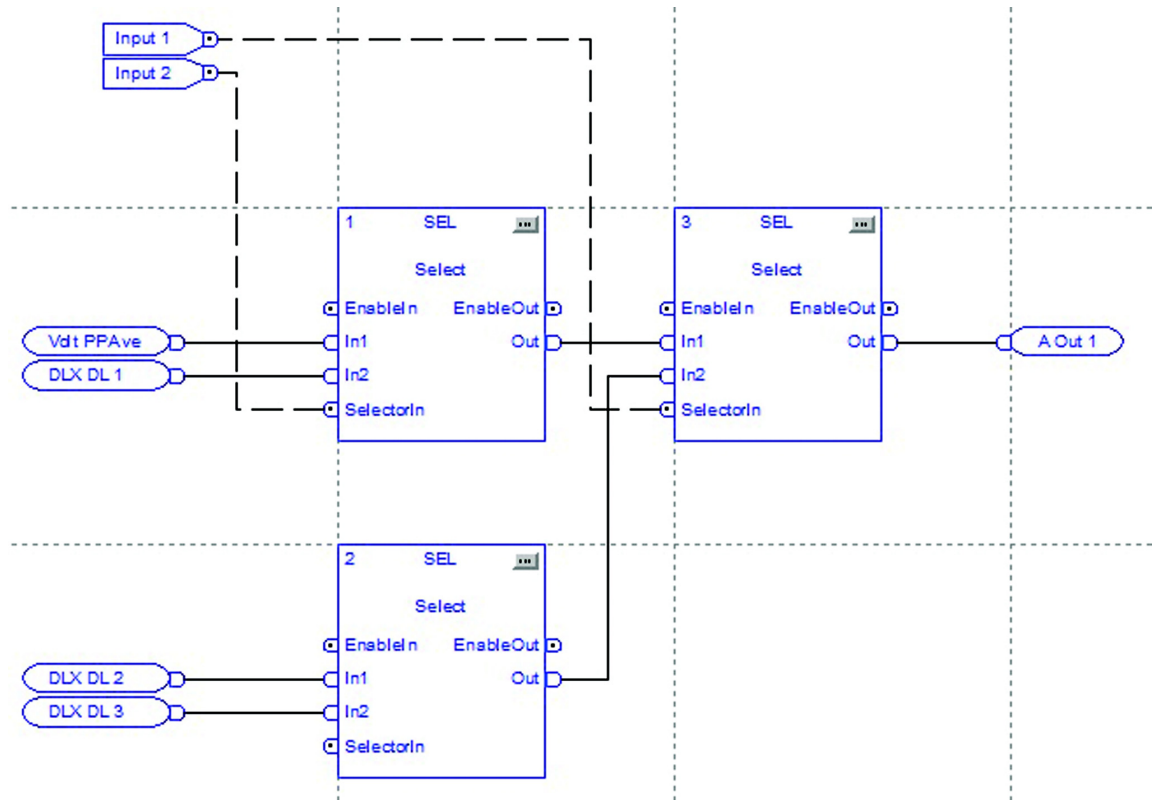

Example 2: Diverter Operation

This example demonstrates basic control logic to operate a diverter in a conveyor system using a in Digital I/O (150-SM4) option module card installed in Port #8. The diverter directs parts from an upstream conveyor to one of two downstream conveyors. The parameter “DLX Input 1” (parameter # 335) defines the total number of boxes diverted to conveyor “A” (when the diverter control signal is off). The parameter “DLX Input 2” (parameter # 336) defines the total number of boxes diverted to conveyor “B” (when the diverter control signal is on).

Figure 114 - Diverter Operation

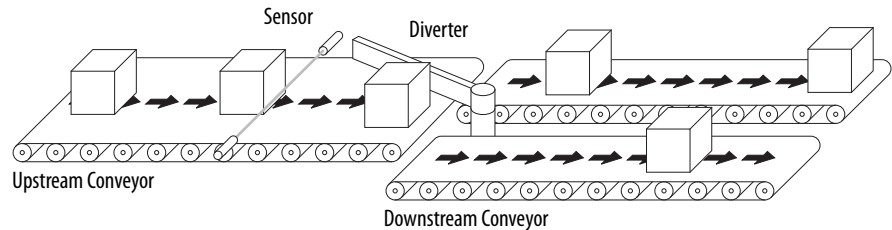

The application consists of the discrete I/O that is shown in [Table 173](#)

Table 173 - Diverter I/O

Type	Name	Description
Inputs	Part Present Sensor	Identifies that a part is present – Connected to Input #1 on an Digital I/O (150-SM4) card installed in Port #8
Outputs	Diverter Actuator	Controls the diverter actuator to direct the flow of parts – Connected to Aux #1 on an Digital I/O (150-SM4) card installed in Port #8

Example logic requirements:

- When Part Present Sensor transitions to ON increment the parts counter
- If parts counter is greater than or equal to “DLX Input 1” then set the diverter actuator
- When the counter reaches “DLX Input 1” + “DLX Input 2” reset the counter.

Parameter Configuration

The parameters in [Table 174](#) are configured for this example.

Table 174 - Diverter Parameter Configuration

Port Parameter No.	Parameter	Value	Description
335	DLX Input 1	5	Send 5 boxes down conveyor “A”
336	DLX Input 2	5	Send 5 boxes down conveyor “B”
8.6 Port #8 Parameter #6	Aux 1 Config	Device Logix	Auxiliary #1 is used to control the Diverter. In order for Device Logix to control the Auxiliary it must be configured to “Device Logix”.

Figure 115 - Function Block Programming

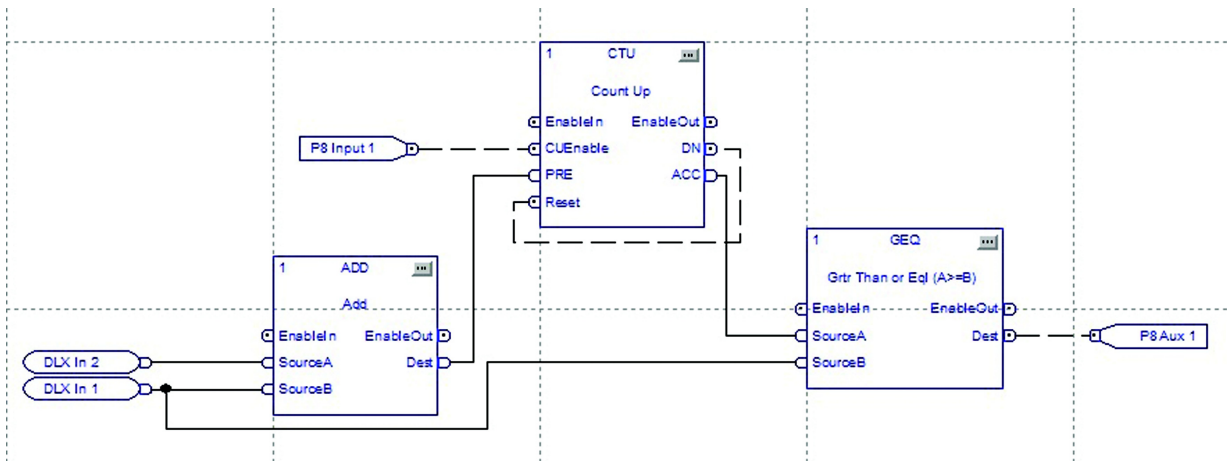

Example 3: Wet Well Operation

This example demonstrates how you can use basic control logic for motor control. It is assumed that a Digital I/O (150-SM4) option module is installed in Port #8.

Figure 116 - Wet Well

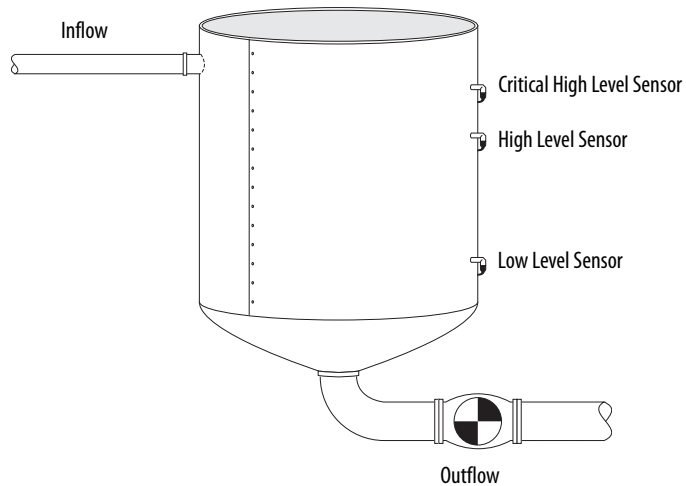

The application consists of the discrete I/O that is listed in [Table 175](#)

Table 175 - Wet Well Discrete I/O

Type	Location of I/O	Name	Description
Inputs	Port #8 Input #2	Critical High Level sensor	Indicates a critically high level. It is normally a backup to the High Level sensor and is also used to detect whether the High Level sensor is faulty.
	Port #8 Input #3	High Level sensor	Indicates the well is at a high level and it is time to start pumping using the SMC-50 controller.
	Port #8 Input #4	Low Level sensor	When OFF, it is used to indicate that the well is empty (as long as the High and Critical High Level sensors are also OFF). The SMC-50 controller stops operating (end of pumping cycle).
Outputs	Port #8 Aux #1	Sensor Failure pilot light	Indicates that there is a problem with either the High Level or Low Level sensors
	Port #8 Aux #2	Critical Level Pilot light	Indicates that the Critical Level Sensor is active.
	No External Wiring	Start	Start signal to the SMC-50 controller.
	No External Wiring	Stop	Stop signal to the SMC-50 controller.

Example logic requirements:

- Start the motor when the High Level Sensor is ON.
- Stop the motor when all the level sensors are OFF.
- Annunciate a Sensor Fault condition and Stop the SMC-50 controller when any of these conditions exist:
 - The Low Level sensor is OFF when either the High Level or Critical High Level sensors are ON
 - The High Level sensor is OFF when the Critical High Level sensor is ON
- Activate the Critical High Level Pilot when the Critical High Level sensor is active.
- Reset alarms / faults with a Reset push button input

Parameter Configuration

The parameters that are listen in [Table 176](#) are configured for this example.

Table 176 - Wet Well Parameter Configuration

Port Parameter No.	Parameter	Value	Description
0.148.14 Host Parameter #148 Bit #14	"Logic Mask"	Set bit #14	Allow DeviceLogix to control the motor.
8.6 Port #8 Parameter #6	"Aux 1 Config"	"Device Logix"	Auxiliary #1 is used to control the Sensor Failure pilot light. In order for DeviceLogix to control the Auxiliary it must be configured to "Device Logix".
8.10 Port #8 Parameter #10	"Aux 2 Config"	"Device Logix"	Auxiliary #2 is used to control the Critical Level pilot light. In order for DeviceLogix to control the Auxiliary it must be configured to "Device Logix".

Figure 117 - Function Block Programming

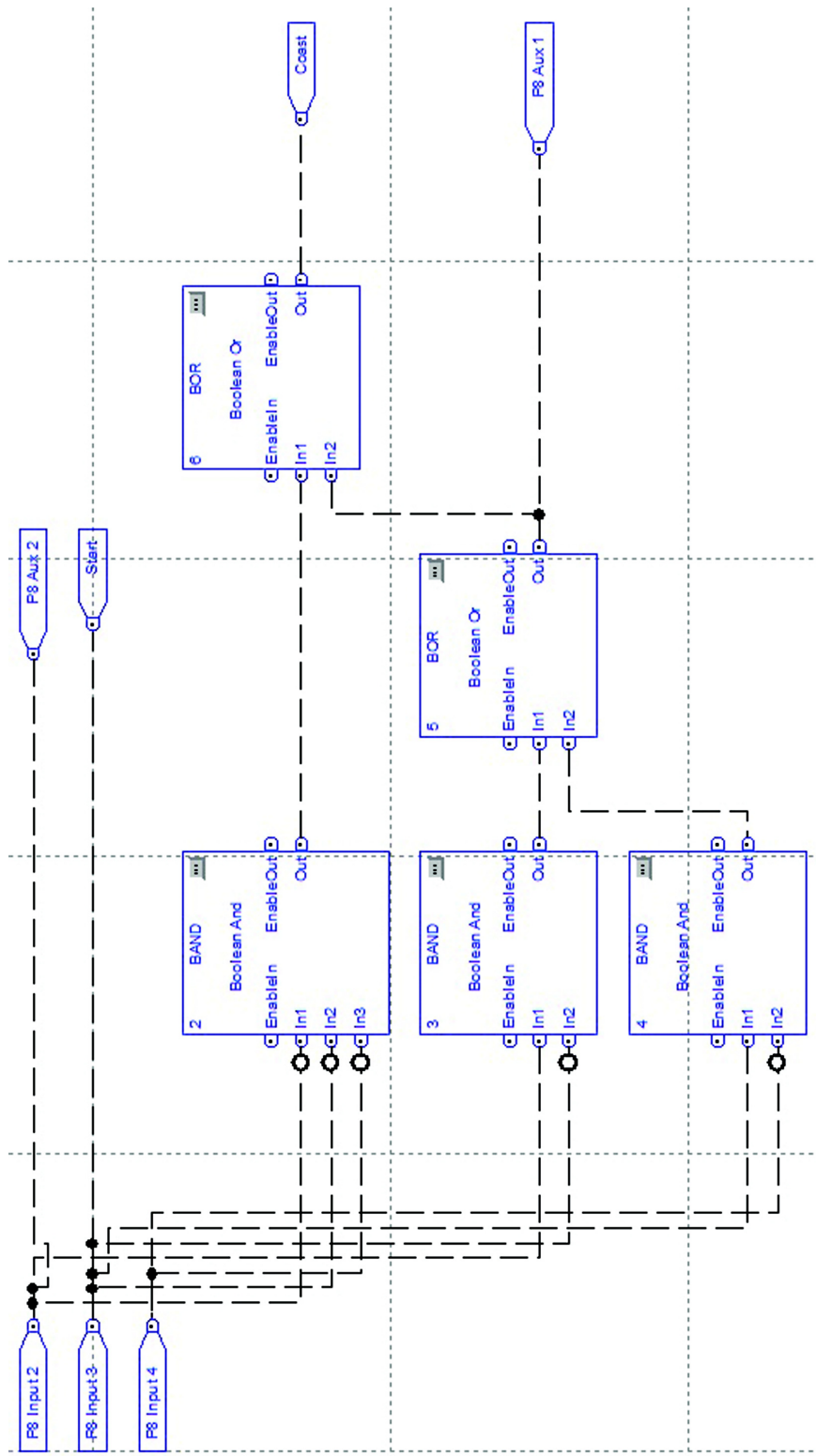

Real Time Clock (RTC) Battery Replacement

The SMC-50 Control Module comes standard with a RTC used to time and date stamp Faults and Alarms. When the control power is not applied to the SMC-50, the operation of the RTC is maintained by an off-the-shelf Lithium™ CR2032 coin cell battery. The battery must be replaced if the SMC-50's low battery alarm is activated.

To replace the battery:

1. Perform the steps that are required to remove the control module. See the control module installation instructions, publication [150-IN078](#).
2. Locate the battery on the circuit board. Note the positive symbol is facing upward.

Bottom Side of SMC-50

Remove and replace battery with positive (+) symbol facing upward.

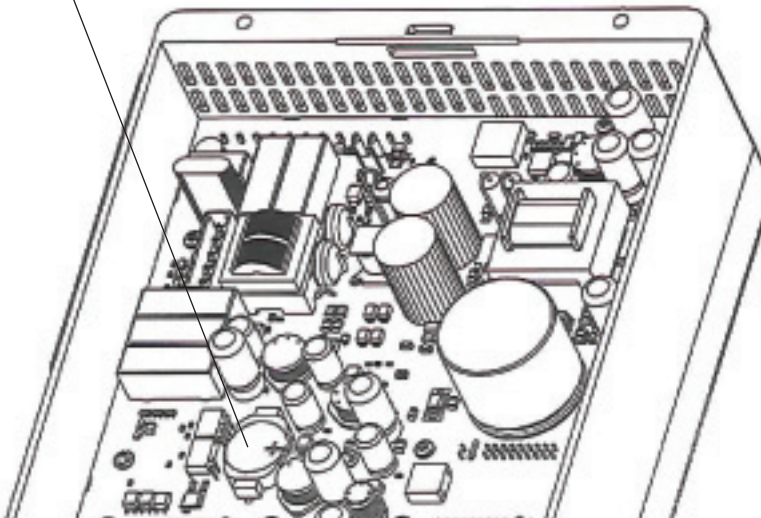

3. Remove the existing battery, disposing of it according to local environmental codes.
4. With the positive symbol of the new battery facing upward, properly seat the battery into place.
5. Perform the steps that are required to replace the control module. See the control module installation instructions, publication [150-IN078](#)
6. Reprogram/reset the clock.

Notes:

Numerics

- 150-SM2 ground fault module**
 - parameter information 274
- 150-SM2 PTC module** 281
- 150-SM3 analog I/O module** 280
 - wiring diagram 281
- 150-SM4 digital I/O module** 280
 - parameter information 269
- 150-SM6** 33
 - parameter information 269
- 150-SM6 parameter configuration module**
 - 287
- 20-HIM-A6** 33
- 20-HIM-A6, 20-HIM-C6S, and Configuration Software** 122

A

- Accu-Stop** 25, 93
 - timing diagram 25
- Accu-Stop option**
 - sequence of operation 103
 - wiring diagrams 65
- additional resources** 11
- Alarm Indication** 236
- alarms** 32
- Altitude** 107
- application considerations** 107
- Application Uses** 117
- Atmospheric Protection** 108
- auxiliary relay**
 - alarm indication 236
 - output fault 236
- Auxiliary Relay Output Fault** 236

B

- backspin timer** 88
- braking**
 - external 25
- braking control modes** 23
 - Accu-Stop 25
 - external braking control 25
 - slow speed with braking 24
 - smart motor braking 24

C

- changes, summary of** 14
- clear fault** 228
- coast** 21
- coast-to-stop** 22, 89
- communications** 30
 - device peripheral interface DeviceLogix 30

configuration

- controller parameter 32
- keypad and LCD 33
- parameter configuration option module 33
- PC programmable software 33
- control inputs and outputs** 34
 - optional inputs 35
 - standard and optional outputs 35
 - standard inputs 34
- control options** 90, 98
- control wiring** 48
 - specifications 48
 - standard control terminal block 48
- controller overview** 75, 121
- controller parameter configuration** 32
- Controller Power Structures** 117
- Current and Thermal Ratings** 107
- Current Imbalance Protection—Fault and Alarm** 131
- current limit start** 18, 82
 - programming parameters 170
 - timing diagram 18
- current transformer interface** 36
- CWE 4 converter module**
 - with overload protection 126

D

- design philosophy** 107
- device peripheral interface**
- DeviceLogix** 30
 - function block element 289
 - parameters 289
 - using 289
- diagnostics** 125, 130, 225
- DPI. See device peripheral interface**
- dual ramp start** 20
 - description of 86
 - programming parameters 175
 - timing diagram 20
 - wiring diagram of 52

E

- electromagnetic compatibility** 42
 - additional requirements 42
 - enclosure 42
 - wiring 42
- electronic motor overload** 31
- EMC. See electromagnetic compatibility**
- emergency run** 27, 98
- Enabling Option Module Functional Faults and Alarm** 125
- Enabling Starter and Motor Faults and Alarms** 122
- enclosure** 42
- excessive starts per hour** 31
- explosion hazard** 13

external braking control 25, 95
external bypass – optional run operation 26
external bypass control 95
external bypass power wiring 44
External Motor Winding Heater 111

F

fan
wiring 73
fan wiring 73
integrated bypass units 73
solid-state units 73
upgraded units 73
fault
auxiliary relay output 236
buffer 228
display 227
fault display explanation 238
faults 32
features 16
motor and starter protection 27
motor protection 31
starter protection 28
full voltage start 20, 83
description of 88
timing diagram 20

G

General 11
General Precautions 11
ground fault 36

H

High and Low Line Power Frequency Protection—Fault and Alarm 133
human interface module 211
human interface module (HIM) 216
connecting the HIM to the controller 216

I

indicators
controller 15
inputs
control 34
optional 35
standard 34
inputs and outputs
control 34
installation 37, 107
Intelli-Brake option
description 90
Intelli-Stop option
wiring diagrams 68
Intell-Stop
wiring diagrams 67

internal bypass mode 25
internal bypass modes 95
Internal Motor Winding Heater 111

J

jam detection 31

L

Line Power Overvoltage Protection—Fault and Alarm 131
Line Power Undervoltage Protection 130
line voltage 107
linear acceleration 79
linear speed (linear deceleration) 90
linear speed acceleration
timing diagram 17
linear speed deceleration 22
timing diagram 23
linear speed acceleration 17
linear speed 79
timing diagram 80

M

Mechanical Shock and Vibration 107
metering 203
modes
starting 16
stopping 21
Motor Overload Protection 108
motor protection
electronic motor overload 31
excessive starts per hour 31
stall protection and jam detection 31
underload 31
user-configurable alarms and faults 32
motor protection features 31
motor tuning 75
Motor Winding Heater 111
motor winding heater
function 88
Multiple motors 109

N

Noise and Radio Frequency (RF) Immunity
107

O

- operating modes** 75
 - internal bypass 25
 - motor configuration 75
 - motor tuning 75
 - resistive loads 76
 - starting 16
 - starting modes 79
 - stopping 21
- option module**
 - parameter configuration 33
- option modules** 279
- optional inputs** 35
- options** 211
- outputs**
 - control 34
 - current transformer 36
 - ground fault 36
 - PTC 36
 - standard and optional 35
- overload protection** 126
- overview**
 - product 15

P

- parameter**
 - electrically erasable programmable read-only memory (EEPROM) 161
 - management of 197
 - modification of 168
 - random access memory (RAM) 160
 - read-only memory (ROM) 160
- parameter information** 245
 - 150-SM2 ground fault module 274
 - 150-SM3 analog I/O module 275
 - 150-SM4 digital I/O module 269
 - 150-SM6 PCM 269
 - SMC-50 Controller 245
- perchlorate material** 13
- Phase Reversal Protection** 133
- Pollution** 108
- port locations** 15
- power** 37
- Power Factor Correction Capacitors** 114
- power module (and interface board)**
 - resistance check** 244
 - preparation 244
 - shorted SCR test 244
- power wiring with external bypass**
 - delta-connected motors 47
 - line-connected motors 44
- Precautions** 11
- preset slow speed** 21, 92
 - timing diagram 21
- preset slow speed option**
 - sequence of operation 100
 - wiring diagrams 65
- product overview** 15
- Protection and Diagnostic Functions** 121

protection and diagnostics 125

- overload 126
- stall and jam 134
- underload 129

protective modules 41**PTC outputs** 36**pump control**

- wiring diagrams 67

pump control mode 19

- timing diagram 19

pump control start and stop 85**pump stop** 23

- timing diagram 23

R**resistive loads** 76

- three-phase balanced loads 77

resistor loads 27**running modes** 95

- emergency run 27
- resistor loads 27
- solid-state 26

S**scr control**

- energy saver run 26

SCR control - energy saver run operation 26**SCR control - normal run operation** 26**selectable kickstart** 19, 81

- timing diagram 19

sequence of operation 98**Setup** 108**slow speed with braking** 24, 92

- timing diagram 24

smart motor braking 24, 91

- timing diagram 24

SMB. See smart motor braking**soft start** 16, 80

- timing diagram 17, 81

soft start option

- description of 79

soft stop 22

- timing diagram 22
- wiring diagrams 67

soft stop option

- description 90
- sequence of operation 99

soft stop/pump control/Intelli-Brake**options**

- wiring diagrams 62, 63

solid-state (SCR) control 95**solid-state running modes** 26

- external bypass – optional run operation 26
- SCR control - energy saver run operation 26
- SCR control - normal run operation 26

solid-state units

- fan wiring 73

Special Motors 109

specifications

control wiring 48

stall protection 31**stall protection and jam detection** 31**stall protection and jam protection** 134**standard and optional outputs** 35**standard control terminal block** 48**standard controller wiring diagrams** 50, 52, 53, 54, 55, 56, 58, 60, 61, 67**standard controller wiring options** 64**standard inputs** 34**start timer (start delay)** 87**starter protection**

communications 30

metering system 29

overvoltage 28

undervoltage 28

voltage unbalance 28

starting modes 16, 79

current limit start 18

dual ramp start 20

full voltage start 20

linear speed acceleration 17

liner speed 79

preset slow speed 21

pump control mode 19

selectable kickstart 19

soft start 16

torque control start 18

stopping modes 21, 89

coast 21

linear speed deceleration 22

pump stop 23

soft stop 22

T**terminal locations** 37

180A through 360A 37

wiring 37

terminology 11**three-phase balanced loads** 77**timed start** 88**timing diagram**

Accu-Stop 25

coast-to-stop 22

current limit start 18

dual ramp start 20

full voltage start 20

linear speed acceleration 17

linear speed deceleration 23

liner speed 80

preset slow speed 21

pump control mode 19

pump stop 23

selectable kickstart 19

slow speed with braking 24

smart motor braking 24

soft start 17, 81

soft stop 22

torque control start 18

torque control start 18, 84

timing diagram 18

trip curves 130**troubleshooting** 237

fault display explanation 238

flowchart 237, 238

troubleshooting tables 242, 243

U**underload** 31, 129**upgraded units**

fan wiring 73

user-configurable alarms and faults 32**V****viewing metering data** 203**Voltage Unbalance Protection—Fault and Alarm** 132**W****wiring** 37, 42

control 48

electromagnetic compatibility 42

fan 73

power 37

power wiring with external bypass 44

protective modules 41

terminal locations 37

wiring diagrams

standard controller 50

Rockwell Automation Support

Use the following resources to access support information.

Technical Support Center	Knowledgebase Articles, How-to Videos, FAQs, Chat, User Forums, and Product Notification Updates.	https://rockwellautomation.custhelp.com/
Local Technical Support Phone Numbers	Locate the phone number for your country.	http://www.rockwellautomation.com/global/support/get-support-now.page
Direct Dial Codes	Find the Direct Dial Code for your product. Use the code to route your call directly to a technical support engineer.	http://www.rockwellautomation.com/global/support/direct-dial.page
Literature Library	Installation Instructions, Manuals, Brochures, and Technical Data.	http://www.rockwellautomation.com/global/literature-library/overview.page
Product Compatibility and Download Center (PCDC)	Get help determining how products interact, check features and capabilities, and find associated firmware.	http://www.rockwellautomation.com/global/support/pcdc.page

Documentation Feedback

Your comments will help us serve your documentation needs better. If you have any suggestions on how to improve this document, complete the How Are We Doing? form at http://literature.rockwellautomation.com/idc/groups/literature/documents/du/ra-du002_-en-e.pdf.

Rockwell Automation maintains current product environmental information on its website at <http://www.rockwellautomation.com/rockwellautomation/about-us/sustainability-ethics/product-environmental-compliance.page>.

Allen-Bradley, Connected Components Workbench, DeviceLogix, DPI, DriveExplorer, DriveExecutive, PowerFlex, Rockwell Software, Rockwell Automation, RSNetWorx, SCANPort, SMC, SMC-50, and SMC Flex are trademarks of Rockwell Automation, Inc.

Trademarks not belonging to Rockwell Automation are property of their respective companies.

Rockwell Otomasyon Ticaret A.Ş., Kar Plaza İş Merkezi E Blok Kat:6 34752 İçerenköy, İstanbul, Tel: +90 (216) 5698400

www.rockwellautomation.com

Power, Control and Information Solutions Headquarters

Americas: Rockwell Automation, 1201 South Second Street, Milwaukee, WI 53204-2496 USA, Tel: (1) 414.382.2000, Fax: (1) 414.382.4444

Europe/Middle East/Africa: Rockwell Automation NV, Pegasus Park, De Kleetlaan 12a, 1831 Diegem, Belgium, Tel: (32) 2 663 0600, Fax: (32) 2 663 0640

Asia Pacific: Rockwell Automation, Level 14, Core F, Cyberport 3, 100 Cyberport Road, Hong Kong, Tel: (852) 2887 4788, Fax: (852) 2508 1846

Publication 150-UM011D-EN-P - November 2017

Supersedes Publication 150-UM011C-EN-P - March 2014 and 150-AT002C-EN-P - March 2013

Copyright © 2017 Rockwell Automation, Inc. All rights reserved. Printed in the U.S.A.